

fischer elektronik



to cool to protect to connect



f.cool.e

Heatsinks Cooling aggregates Thermal conductive materials



The information given in this catalogue were established and examined carefully. Nevertheless, mistakes or printing errors, and especially technical modifications and updating and improvement of our products, cannot be excluded. All trade marks are recognised even if they are not specifically identified or mentioned. No identification does not imply that a product or trademark is not registered. No part of this catalogue may be reproduced or distributed without prior written consent of Fischer Elektronik. All data contained in this catalogue, in texts, illustrations, documents and descriptions are subject to copyright and the provisions of DIN ISO 16016.

All rights reserved. © Copyright Fischer Elektronik 1968 ... 2024

Fischer Elektronik GmbH & Co. KG

P.O. Box 15 90
58465 Lüdenscheid
GERMANY

House address

Nottebohmstr. 28 • 58511 Lüdenscheid
GERMANY

Phone: +49 2351 435-0

Fax:

sales

+49 2351 45754

purchasing

+49 2351 459433

exports

+49 2351 435185

info@fischerelektronik.de
www.fischerelektronik.de/en



flucticulus frigus
from the series
flucticulus,
Homage to Hokusai, 2019

16.000 photos 10 x 15 on cardboard, 60 x 60 cm

from:
Thomas Kellner
www.thomaskellner.com

A	A 1 - A 192				
B	B 1 - B 78				
C	C 1 - C 36				
D	D 1 - D 54				
E	E 1 - E 120				
F	F 1 - F 28				
G	G 1 - G 104				
H	H 1 - H 20				
I	I 1 - I 44				
K	K 1 - K 32				
L	L 1 - L 16				
M	M 1 - M 92				
N	N 1 - N 70				

<p>Extruded profiles: extruded heatsinks, extruded heatsinks for lock-in retaining spring, extruded heatsinks for PCB mounting, fin coolers, fluid coolers, high-performance heatsinks</p>	<p>A 1 – A 192</p>	<p>A</p>
<p>Heatsinks for processors and LED: heatsinks and fan coolers for universal PGA/BGA, DIL, PLCC, heatsinks for LED, pin heatsinks</p>	<p>B 1 – B 78</p>	<p>B</p>
<p>Board level heatsinks: finger-shaped heatsinks, heatsinks for transistors in plastic case, attachable heatsinks, small heatsinks, copper heatsinks for D PAK and others</p>	<p>C 1 – C 36</p>	<p>C</p>
<p>Cooling aggregates: miniature cooling aggregates, heatsink cooling aggregates, high capacity cooling aggregates, multi module cooling aggregates, hollow-fin aggregates, cooling aggregates with axial fan</p>	<p>D 1 – D 54</p>	<p>D</p>
<p>Thermal interface material and accessories for electronic components: thermally conductive foil made of siliconelastomer, silicone-free thermal conductive foils, GEL thermal conductive foils, aluminium oxide wafers, mica wafers, thermal conductive paste, thermally conductive adhesive, fixing clamp for mounting rail, guide rails, mounting material for heatsinks</p>	<p>E 1 – E 120</p>	<p>E</p>
<p>Sockets: IC-sockets for DIL, PLCC, sockets for transistors, crystal oscillators and connector-sleeves</p>	<p>F 1 – F 28</p>	<p>F</p>
<p>PCB connectors and accessories: male and female headers, grid spacing 2.54; 2.50; 2.00 and 1.27 mm, high precision contact strips, direct female connectors, jumpers</p>	<p>G 1 – G 104</p>	<p>G</p>
<p>IDC connectors: design DIL, shroud-male header, single and double row female headers, lockable connectors, ribbon cable</p>	<p>H 1 – H 20</p>	<p>H</p>
<p>D-Sub connectors: USB connectors, RJ45 connectors, D-Sub male and female headers, connectors with mounting option, connectors for ribbon cable, mixed layout connectors, SMD connectors, cover, accessories</p>	<p>I 1 – I 44</p>	<p>I</p>
<p>Brackets: brackets for PC and PCI with or without fixing tab, retainer for ISA versions</p>	<p>K 1 – K 32</p>	<p>K</p>
<p>Optoelectronics: LED-holders for front panel assembly, LED-holder without LED, LED-holder with mounted LED, light pipes for SMDs</p>	<p>L 1 – L 16</p>	<p>L</p>
<p>Cases: shell cases, extruded assembled cases, desk consoles, combination cases, tube cases, miniature aluminium cases, cooling cases, LED line modules, design cases, special front panels, accessories for cases</p>	<p>M 1 – M 92</p>	<p>M</p>
<p>19" Extension systems: basic case (Rack), plug-in chassis, subracks, insert modules, part front panels, rack handles, PCB holder, accessories</p>	<p>N 1 – N 70</p>	<p>N</p>

Alphanumerical product list

art. no.	page	art. no.	page	art. no.	page	art. no.	page
ABM 2550	E 105	DR 810 V0	E 107	FK 245 MI 247 O	C 12	FK 283	C 35
ABM 3050	E 105	DR 811 V0	E 107	FK 245 MI 247 V	C 12	FK 318 1 SA	C 2
ABM 4070	E 105	DR 812 V0	E 107	FK 247 220	C 7	FK 318 1 SA 3	C 2
ABM 5080	E 105	DR 813 V0	E 107	FK 248 SA 220	C 11	FK 318 SA 3	C 2
ABM TE 04	E 106	DR 814 V0	E 107	FK 249 SA 220	C 5	FL 0,55	A 175
ABM TE 04 DIN	E 106	DR 815 V0	E 107	FK 250 06 LF PAK	C 34	FL 1,1	A 175
ABM TE 06	E 106	DR 820 V0	E 107	FK 250 08 LF PAK	C 34	FLK HB 1	A 179
ABM TE 06 DIN	E 106	DR 825 V0	E 107	FK 250 10 LF PAK	C 34	FLKI 80	A 180
ABM TE 08	E 106	DR 830 V0	E 107	FK 251 06 LF PAK	C 34	FLKI 80 G 200	A 181
ABM TE 08 DIN	E 106	DR 835 V0	E 107	FK 251 08 LF PAK	C 34	FLKI 80 G 300	A 181
ABP 2550	E 105	DR 840 V0	E 107	FK 251 10 LF PAK	C 34	FLKI 80 G 500	A 181
ABP 3060	E 105	DR 845 V0	E 107	FK 252 SA 220 H	C 27	FLKI 295	A 182
ABP 4080	E 105	DR 850 V0	E 107	FK 252 SA 220 V	C 27	FLKI 400 G 400	A 183
AD LED 53	B 55	DR 860 V0	E 107	FK 252 SA 220 VL	C 27	FLKR 1	A 184
AHG K 27	E 97	ELS 3	A 127	FK 253	C 28	FLKU 10 ...	A 185
AHG K 28	E 97	ELS 3 B	NEW A 127	FK 254 1 SA	C 2	FLKU 140	A 180
AHG L 7	E 97	EPN 1	E 111	FK 254 1 SA 3	C 2	FLKU 140 G 200	A 181
AHG V 14	E 97	FK 201 SA	C 2	FK 255	C 28	FLKU 140 G 300	A 181
AHG V 17	E 97	FK 201 SA 3	C 2	FK 256	C 34	FLKU 140 G 500	A 181
AHM 3260	E 106	FK 201 SA CB	C 2	FK 257	C 28	FS 6 065	E 92
AHM 4380	E 106	FK 202 SA	C 2	FK 258 SA 220	C 10	FS 6 070	E 92
AKK 127	A 173	FK 202 SA 3	C 2	FK 259 MI 220 H	C 13	FS 6 080	E 92
AKK 191	A 173	FK 202 SA CB	C 2	FK 259 MI 220 O	C 13	FS 6 090	E 92
AOS 3	E 73	FK 205 SA L	C 3	FK 259 MI 220 V	C 13	FS 6 100	E 92
AOS 3 P	E 73	FK 206 SA L	C 3	FK 260 MI 220 H	C 13	FS 6 110	E 92
AOS 3 P 2	E 73	FK 207 SA L	C 3	FK 260 MI 220 O	C 13	FS 6 120	E 92
AOS 3 P SL	E 73	FK 208 SA L	C 3	FK 260 MI 220 V	C 13	FS 6 130	E 92
AOS 5	E 73	FK 209 SA 32	C 6	FK 261 MI 220 H	C 14	FS 85	E 94
AOS 18	E 73	FK 210 SA CB	C 6	FK 261 MI 220 O	C 14	FS 85 50	E 94
AOS 32	E 73	FK 211 32	C 7	FK 261 MI 220 V	C 14	FS 85 60	E 94
AOS 66	E 73	FK 212 CB	C 7	FK 262 MI 220 H	C 14	FS 85 70	E 94
AOS 93	E 73	FK 213 SA 32	C 6	FK 262 MI 220 O	C 14	FS 100	E 92
AOS 127	E 73	FK 214 SA CB	C 6	FK 262 MI 220 V	C 14	FS 109	E 92
AOS 218 247	E 73	FK 215 32	C 7	FK 263 MI 220 H	C 15	FS BF 06	E 95
AOS 218 247 1	E 73	FK 216 CB	C 7	FK 263 MI 220 O	C 15	FS BF 07	E 95
AOS 220	E 73	FK 217 SA CB 2	C 3	FK 263 MI 220 V	C 15	FS BF 10	E 95
AOS 220 3	E 73	FK 218 32	C 8	FK 264 MI 220 H	C 15	FS BF 11	E 95
AOS 220 4	E 73	FK 219 CB 1	C 9	FK 264 MI 220 O	C 15	FS BF 13	E 95
AOS 220 SL	E 73	FK 219 CB 2	C 9	FK 264 MI 220 V	C 15	FS BF 15	E 95
AOS 247	E 73	FK 219 CB 3	C 9	FK 265 MI 220 H	C 16	FS BF 19	E 95
AOS P 1	E 74	FK 220 SA 220	C 10	FK 265 MI 220 O	C 16	FS BF 20	E 95
AOS P 1.1	E 74	FK 222	C 7	FK 265 MI 220 V	C 16	FS BT 06	E 95
AOS P 2	E 74	FK 222 THF	C 7	FK 266 MI 220 H	C 16	FS BT 08	E 95
AOS P 3	E 74	FK 223 SA	C 3	FK 266 MI 220 O	C 16	FS BT 10	E 95
AOS P 4	E 74	FK 223 SA 3	C 3	FK 266 MI 220 V	C 16	FS BT 11	E 95
AOS P 5	E 74	FK 223 SA CB	C 3	FK 267 MI 220 H	C 17	FS BT 13	E 95
AOS P 6	E 74	FK 224 ... 218 1	C 11	FK 267 MI 220 O	C 17	FS BT 15	E 95
AOS P 7	E 74	FK 224 ... 218 2	C 11	FK 267 MI 220 V	C 17	FS BT 16	E 95
AOS P 8	E 74	FK 224 ... 220 1	C 11	FK 268 MI 220 H	C 17	FS BT 19	E 95
AOS P 9	E 74	FK 224 ... 220 2	C 11	FK 268 MI 220 O	C 17	FS BT 20	E 95
AOS P 10	E 74	FK 224 ... P SIP	C 10	FK 268 MI 220 V	C 17	FSF 15 P 011	E 75
DR 071 V0	E 107	FK 225 SA L 1	C 5	FK 269 MI 220 H	C 18	FSF 15 P 012	E 75
DR 072 V0	E 107	FK 225 SA L 2	C 5	FK 269 MI 220 O	C 18	FSF 15 P 014	E 75
DR 073 V0	E 107	FK 227 SA L 1	C 8	FK 269 MI 220 V	C 18	FSF 16 P 010	E 76
DR 074 V0	E 107	FK 228 SA L 1	C 5	FK 270 MI 220 H	C 18	FSF 16 P 011	E 76
DR 075 V0	E 107	FK 229 SA L 1	C 5	FK 270 MI 220 O	C 18	FSF 16 P 012	E 76
DR 076 V0	E 107	FK 230 SA L 1	C 5	FK 270 MI 220 V	C 18	FSF 20 P	E 77
DR 077 V0	E 107	FK 231 SA 220	C 6	FK 271 MI 247 H	C 19	FSF 30 P	E 77
DR 078 V0	E 107	FK 232 220	C 8	FK 271 MI 247 O	C 19	FSF 50 P 012	NEW E 78
DR 079 V0	E 107	FK 233 220	C 8	FK 271 MI 247 V	C 19	FSF 50 P 020	NEW E 78
DR 081 V0	E 107	FK 234 SA L 1	C 4	FK 272 MI 247 H	C 19	FSF 50 P 025	NEW E 78
DR 082 V0	E 107	FK 234 SA L 2	C 4	FK 272 MI 247 O	C 19	FS LP 05	E 96
DR 083 V0	E 107	FK 234 SA L 3	C 4	FK 272 MI 247 V	C 19	FS LP 07	E 96
DR 084 V0	E 107	FK 234 SA L 4	C 4	FK 273 MI 247 H	C 20	FS LP 08	E 96
DR 085 V0	E 107	FK 235 ... L 1	C 4	FK 273 MI 247 O	C 20	FS LP 10	E 96
DR 086 V0	E 107	FK 235 ... L 2	C 4	FK 273 MI 247 V	C 20	FS LP 11	E 96
DR 087 V0	E 107	FK 236 220	C 9	FK 274 MI 247 H	C 20	FS LP 13	E 96
DR 088 V0	E 107	FK 236 CB	C 9	FK 274 MI 247 O	C 20	FS LP 15	E 96
DR 089 V0	E 107	FK 237 SA 220 H	C 26	FK 274 MI 247 V	C 20	FS LP 16	E 96
DR 105 V0	E 107	FK 237 SA 220 O	C 25	FK 275 MI 247 H	C 21	FS LP 17	E 96
DR 110 V0	E 107	FK 237 SA 220 V	C 26	FK 275 MI 247 O	C 21	FS LP 22	E 96
DR 115 V0	E 107	FK 237 SA 220 VL	C 26	FK 275 MI 247 V	C 21	FS LP 30	E 96
DR 120 V0	E 107	FK 238 SA L 1	C 8	FK 276 MI 247 H	C 21	FS S 06 2	E 95
DR 125 V0	E 107	FK 239 SA 32	C 6	FK 276 MI 247 O	C 21	FS S 07 2	E 95
DR 130 V0	E 107	FK 240 SA 220 H	C 26	FK 276 MI 247 V	C 21	FS S 08 2	E 95
DR 135 V0	E 107	FK 240 SA 220 O	C 25	FK 277 MI 247 H	C 22	FS S 10 2	E 95
DR 140 V0	E 107	FK 240 SA 220 V	C 26	FK 277 MI 247 O	C 22	FS S 11 2	E 95
DR 145 V0	E 107	FK 240 SA 220 VL	C 26	FK 277 MI 247 V	C 22	FS S 12 2	E 95
DR 150 V0	E 107	FK 241 SA 218 V	C 11	FK 278 MI 247 H	C 22	FS S 13 2	E 95
DR 710 V0	E 107	FK 242 SA 220 H	C 26	FK 278 MI 247 O	C 22	FS S 15 2	E 95
DR 711 V0	E 107	FK 242 SA 220 O	C 25	FK 278 MI 247 V	C 22	FS S 16 2	E 95
DR 712 V0	E 107	FK 242 SA 220 V	C 26	FK 279 MI 247 H	C 23	FS S 19 3	E 95
DR 713 V0	E 107	FK 242 SA 220 VL	C 26	FK 279 MI 247 O	C 23	FS S 20 3	E 95
DR 714 V0	E 107	FK 243 MI 247 H	C 12	FK 279 MI 247 V	C 23	FS S 21 2	E 95
DR 715 V0	E 107	FK 243 MI 247 O	C 12	FK 280 MI 247 H	C 23	FS S 21 3	E 95
DR 720 V0	E 107	FK 243 MI 247 V	C 12	FK 280 MI 247 O	C 23	FS U 06	E 96
DR 725 V0	E 107	FK 244 08 D2 PAK	C 33	FK 280 MI 247 V	C 23	FS U 11	E 96
DR 730 V0	E 107	FK 244 08 D3 PAK	C 33	FK 281 MI 247 H	C 24	FS U 20	E 96
DR 735 V0	E 107	FK 244 08 D PAK	C 33	FK 281 MI 247 O	C 24	GBM 2550	E 103
DR 740 V0	E 107	FK 244 13 D2 PAK	C 33	FK 281 MI 247 V	C 24	GBM 3050	E 103
DR 745 V0	E 107	FK 244 13 D3 PAK	C 33	FK 282 MI 247 H	C 24	GBM 4070	E 103
DR 750 V0	E 107	FK 244 13 D PAK	C 33	FK 282 MI 247 O	C 24	GBM 5080	E 103
DR 760 V0	E 107	FK 245 MI 247 H	C 12	FK 282 MI 247 V	C 24	GBMS 2550	E 104

Alphanumerical product list

art. no.	page	art. no.	page	art. no.	page	art. no.	page
GBMS 3055 29	E 104	ICK 14 H	B 65	ICK PEN 38 F	B 73	ICK SMD BOX 1	B 69
GBMS 3055 33	E 104	ICK 16 H	B 65	ICK PEN 38 W	B 73	ICK SMD C 7 SA	B 67
GBMS 3060	E 104	ICK 18 H	B 65	ICK PEN 45 W	B 73	ICK SMD C 10 SA	B 67
GBMS 4070	E 104	ICK 20 L	B 65	ICK PGA 6 x 6 x 14	B 12	ICK SMD C 17	B 67
GBMS 5080	E 104	ICK 24 B	B 65	ICK PGA 8 x 8 x 12	B 12	ICK SMD E 15 SA	B 67
GBMS 6010	E 104	ICK 28 B	B 65	ICK PGA 9 x 9	B 12	ICK SMD E 22 SA	B 67
GBP 3060	E 103	ICK 35 SA	A 171	ICK PGA 11 x 11	B 13	ICK SMD E 29 SA	B 67
GBP 4080	E 103	ICK 36 B	B 65	ICK PGA 11 x 11 x 8	B 12	ICK SMD F 8	B 67
GEL 14 ...	E 47	ICK 40 B	B 65	ICK PGA 11 x 11 x 12	B 13	ICK SMD F 8 TR	B 67
GEL 14 G ...		ICK 1000 B	B 65	ICK PGA 14 x 14	B 13	ICK SMD F 10	B 67
GEL 28 ...	E 49	ICK 1000 H	B 65	ICK PGA 14 x 14 x 10	B 13	ICK SMD F 17 SA	B 67
GEL 28 G ...		ICK BGA 10 x 10	B 18	ICK PGA 14 x 14 x 12	B 14	ICK SMD F 19	B 67
GEL 28 S ...	E 60	ICK BGA 10 x 10 x 10	B 18	ICK PGA 14 x 14 x 14	B 13	ICK SMD F 21	B 67
GEL 30 S ...	E 61	ICK BGA 11 x 11 x 6	B 18	ICK PGA 15 x 15	B 14	ICK SMD F 21 TR	B 67
GEL 32 A ...	NEW E 51	ICK BGA 11 x 11 x 10	B 18	ICK PGA 16 x 16 x 8	B 14	ICK SMD F 26	B 67
GEL 45 ...	E 52	ICK BGA 11 x 11 x 14	B 19	ICK PGA 16 x 16 x 10	B 14	ICK SMD G 8 MI	B 68
GEL 45 G ...		ICK BGA 12 x 12 x 18	B 19	ICK PGA 16 x 16 x 12	B 14	ICK SMD G 10	B 68
GEL 45 S ...	NEW E 62	ICK BGA 14 x 14	B 19	ICK PGA 17 x 17	B 15	ICK SMD G 13 SA	B 68
GEL 50 S ...	E 63	ICK BGA 14 x 14 x 10	B 19	ICK PGA 17 x 17 x 8	B 15	ICK SMD G 17 SA	B 68
GEL 60 ...	E 54	ICK BGA 14 x 14 x 14	B 19	ICK PGA 17 x 17 x 12	B 15	ICK SMD G 19 SA	B 68
GEL 60 G ...		ICK BGA 15 x 15 x 6	B 20	ICK PGA 18 x 18	B 15	ICK SMD G 21	B 68
GEL 60 A ...	NEW E 55	ICK BGA 15 x 15 x 10	B 20	ICK PGA 19 x 19	B 16	ICK SMD H 8	B 68
GEL 65 S ...	NEW E 64	ICK BGA 15 x 15 x 14	B 20	ICK PGA 19 x 19 x 12	B 15	ICK SMD H 10	B 68
GEL 70 S ...	E 65	ICK BGA 19 x 19 x 6	B 20	ICK PGA 20 x 20	B 16	ICK SMD H 17	B 68
GEL 80 ...	E 56	ICK BGA 19 x 19 x 10	B 20	ICK PGA 20 x 20 K	B 16	ICK SMD H 19 SA	B 68
GEL 80 G ...		ICK BGA 19 x 19 x 14	B 20	ICK PGA 20 x 20 x 8	B 16	ICK SMD H 25	B 68
GEL 80 S ...	NEW E 66	ICK BGA 21 x 21	B 21	ICK PGA 20 x 20 x 10	B 16	ICK SMD K 8	B 68
GEL 83 A ...	NEW E 57	ICK BGA 21 x 21 x 10	B 21	ICK PGA 20 x 20 x 12	B 17	ICK SMD K 10 SA	B 68
GEL 100 ...	NEW E 58	ICK BGA 21 x 21 x 14	B 21	ICK PGA 21 x 21	B 17	ICK SMD K 13	B 68
GEL 100 G ...		ICK BGA 23 x 23	B 21	ICK PGA 22 x 22	B 17	ICK SMD K 17	B 68
GEL 130 ...	NEW E 59	ICK BGA 23 x 23 x 10	B 21	ICK PGA 25 x 25	B 17	ICK SMD K 19	B 68
GEL 130 S ...	NEW E 67	ICK BGA 25 x 25 x 6	B 21	ICK PLCC 28	B 65	ICK SMD K 19 TR	B 68
GEL F 15 ...	E 44	ICK BGA 25 x 25 x 10	B 22	ICK PPC 51	B 70	ICK SMD K 21	B 68
GEL F 15 G ...		ICK BGA 25 x 25 x 14	B 22	ICK PRO 40 W	B 73	ICK SMD M 8 SA	B 68
GEL F 20 05	NEW E 45	ICK BGA 27 x 27	B 22	ICK R	B 65	ICK SMD M 10 SA	B 68
GEL F 20 10	NEW E 45	ICK BGA 27 x 27 x 10	B 22	ICK S 10 x 10 x 6,5	B 27	ICK SMD M 17 MI	B 68
GEL F 30 ...	E 46	ICK BGA 27 x 27 x 14	B 22	ICK S 10 x 10 x 10	B 27	ICK SMD M 19 SA	B 68
GEL M 18	E 68	ICK BGA 27 x 27 x 22	B 23	ICK S 10 x 10 x 12,5	B 27	ICK SMD M 21 SA	B 68
GEL M 50	E 69	ICK BGA 29 x 29 x 6	B 23	ICK S 10 x 10 x 18,5	B 28	ICK SMD N 8	B 69
GEL S 18	E 68	ICK BGA 29 x 29 x 10	B 23	ICK S 14 x 14 x 6,5	B 28	ICK SMD N 8 TR	B 69
GEL S 20	E 69	ICK BGA 29 x 29 x 14	B 23	ICK S 14 x 14 x 10	B 28	ICK SMD N 10	B 69
GEL S 30	E 69	ICK BGA 31 x 31	B 23	ICK S 14 x 14 x 12,5	B 28	ICK SMD N 17	B 69
GEL S 35	E 70	ICK BGA 31 x 31 x 10	B 24	ICK S 14 x 14 x 18,5	B 28	ICK SMD N 19	B 69
GEL S 35 10	E 70	ICK BGA 33 x 33 x 6	B 24	ICK S 17 x 17 x 15	B 29	ICK SMD N 19 TR	B 69
GEL S 40	E 69	ICK BGA 33 x 33 x 10	B 24	ICK S 17 x 17 x 20	B 29	ICK SMD N 21	B 69
GS 3	E 72	ICK BGA 33 x 33 x 14	B 24	ICK S 18 x 18 x 6,5	B 29	ICK SMD N 26	B 69
GS 3 P	E 72	ICK BGA 35 x 35	B 24	ICK S 18 x 18 x 10	B 29	ICK SMD O 8	B 69
GS 3 P SL	E 72	ICK BGA 35 x 35 x 10	B 25	ICK S 22 x 22 x 6,5	B 29	ICK SMD O 10	B 69
GS 32 P	E 72	ICK BGA 37 x 37 x 6	B 25	ICK S 22 x 22 x 10	B 30	ICK SMD O 17	B 69
GS 66 P	E 72	ICK BGA 37 x 37 x 10	B 25	ICK S 22 x 22 x 18,5	B 30	ICK SMD O 19	B 69
GS 218	E 72	ICK BGA 40 x 40	B 25	ICK S 25 x 25 x 6,5	B 30	ICK SMD O 21	B 69
GS 220 4	E 72	ICK BGA 40 x 40 x 10	B 25	ICK S 25 x 25 x 12,5	B 30	ICK SMD O 25	B 69
GS 220 C	E 72	ICK BGA 42,5 x 45	B 26	ICK S 25 x 25 x 18,5	B 30	ICK S R 28,5 x 6,5	B 37
GS 220 P	E 72	ICK EM 22	B 71	ICK S 29 x 29 x 10	B 31	ICK S R 28,5 x 10	B 37
IB 1	E 119	ICK EM 25	B 71	ICK S 29 x 29 x 20	B 31	ICK S R 28,5 x 12,5	B 37
IB 2	E 119	ICK LED R 23,5 x 14	B 46	ICK S 29 x 29 x 30	B 31	ICK S R 28,5 x 18,5	B 38
IB 3	E 119	ICK LED R 23,5 x 14 G	B 46	ICK S 32 x 32 x 10	B 31	ICK S R 32,5 x 10	B 38
IB 4	E 119	ICK LED R 27 x 10	B 46	ICK S 32 x 32 x 20	B 31	ICK S R 32,5 x 20	B 38
IB 5	E 119	ICK LED R 27 x 10 G	B 46	ICK S 36 x 36 x 10	B 32	ICK S R 32,5 x 30	B 38
IB 6	E 119	ICK LED R 28 x 15	B 46	ICK S 36 x 36 x 15	B 32	ICK S R 32,5 x 40	B 38
IB 7	E 119	ICK LED R 28 x 15 G	B 47	ICK S 36 x 36 x 20	B 32	ICK S R 32,5 x 50	B 39
IB 8	E 119	ICK LED R 29 x 11,5	B 47	ICK S 36 x 36 x 28,5	NEW B 32	ICK S R 36,5 x 20	B 39
IB 9	E 119	ICK LED R 29 x 11,5 G	B 47	ICK S 36 x 36 x 30	B 32	ICK S R 40 x 10	B 39
IB 10	E 119	ICK LED R 32 x 14	B 47	ICK S 40 x 40 x 7,5	B 33	ICK S R 40 x 20	B 39
IB 11	E 119	ICK LED R 32 x 14 G	B 47	ICK S 40 x 40 x 10	B 33	ICK S R 40 x 30	B 40
IB 12	E 119	ICK LED R 33 x 10	B 47	ICK S 40 x 40 x 20	B 33	ICK S R 40 x 50	B 40
IB 13	E 119	ICK LED R 33 x 10 G	B 47	ICK S 40 x 40 x 25	B 33	ICK S R 45 x 30	B 40
IB 14	E 119	ICK LED R 33 x 16,5	B 48	ICK S 45 x 45 x 10	B 33	ICK S R 45 x 45	B 40
IB 15	E 119	ICK LED R 33 x 16,5 G	B 48	ICK S 45 x 45 x 20	B 34	ICK S R 50 x 10	B 40
IB 16	E 119	ICK LED R 35 x 10	B 48	ICK S 50 x 50 x 10	B 34	ICK S R 50 x 20	B 41
IB 17	E 119	ICK LED R 35 x 10 G	B 48	ICK S 50 x 50 x 20	B 34	ICK S R 50 x 30	B 41
IB 18	E 119	ICK LED R 36 x 12	B 48	ICK S 50 x 50 x 25	B 34	ICK S R 50 x 45	B 41
IB 19	E 119	ICK LED R 36 x 12 G	B 48	ICK S 50 x 50 x 40	B 34	ICK S R 54 x 20	B 41
IB 20	E 119	ICK LED R 40 x 10	B 48	ICK S 50 x 50 x 50	B 35	ICK S R 54 x 30	B 41
IB 21	E 119	ICK LED R 40 x 10 G	B 49	ICK S 98 x 98 x 30	B 35	ICK S R 54 x 45	B 42
IB 22	E 119	ICK LED R 40 x 27	B 49	ICK S 98 x 98 x 45	B 35	ICK S R 70 x 30	B 42
IBT 1	E 119	ICK LED R 40 x 27 G	B 49	ICK S D 12 x 12 x 7,5	B 36	ICK S R 70 x 50	B 42
IBT 2	E 119	ICK LED R 45,7 x 16,5	B 49	ICK S D 18 x 12 x 7,5	B 36	ICK S R 85 x 30	B 42
IBT 3	E 119	ICK LED R 45,7 x 16,5 G	B 49	ICK S D 24 x 18 x 7,5	B 36	ICK S R 85 x 45	B 42
IBT 4	E 119	ICK LED R 50,8 x 16,5	B 50	ICK S D 98 x 98 x 10	B 36	ICK S R 98 x 30	B 43
IBT 6	E 119	ICK LED R 50,8 x 16,5 G	B 50	ICK SM 25	B 72	ICK S R 98 x 50	B 43
IBT 7	E 119	ICK LED R 50 x 10	B 49	ICK SMD A 5	B 66	ICK S R 100 x 50	B 43
IBT 8	E 119	ICK LED R 50 x 10 G	B 50	ICK SMD A 8	B 66	ICK S R 100 x 70	B 43
IBT 9	E 119	ICK LED R 54 x 20	B 50	ICK SMD A 10	B 66	ICK S R 120 x 50	B 44
IBT 10	E 119	ICK LED R 54 x 20 G	B 50	ICK SMD A 13	B 66	ICK S R 120 x 70	B 44
IBT 11	E 119	ICK LED R 66 x 40	B 51	ICK SMD A 13 TR	B 66	ICK S R 140 x 50	B 44
IBT 12	E 119	ICK LED R 75 x 10	B 51	ICK SMD A 17	B 66	ICK S R 140 x 70	B 44
IBT 14	E 119	ICK LED R 84 x 40	B 51	ICK SMD A 22	B 66	ICK S R 160 x 70	B 45
IBT 15	E 119	ICK LED R 100 x 40	B 51	ICK SMD B 5	B 67	ICK S R A 40 x 20	B 39
IBT 18	E 119	ICK LED R 160 x 40	B 52	ICK SMD B 7 SA	B 67	ICK VB 10	B 71
ICK 6 8 L	B 65	ICK LED R 200 x 40	B 52	ICK SMD B 10 SA	B 67	ICK VB 15	B 71
ICK 14 16 B	B 65	ICK PEN 3 XE	B 70	ICK SMD B 13 SA	B 67	IK 3	E 118
ICK 14 16 L	B 65	ICK PEN 3 XE 1	B 70	ICK SMD B 19	B 67	IK 341 3	E 118

Alphanumerical product list

art. no.	page	art. no.	page	art. no.	page	art. no.	page
IS 1	E 116	KL 35 L 75	E 89	LA ICK 21 x 21 F 05	B 74	MS 34 518	E 113
IS 2	E 116	KL 35 L 100	E 89	LA ICK 21 x 21 F 12	B 74	MS 53 3	E 113
IS 3	E 116	KL 35 SL 100	E 89	LA ICK 21 x 21 W 05	B 74	MS 53 7	E 113
IS 4	E 116	KSK 1	A 87	LA ICK 21 x 21 W 12	B 74	MS 53 25	E 113
IS 5	E 116	KSK 2	A 87	LA ICK PEN 2 K 12	B 76	MS 54 25	E 113
IS 6	E 116	KSK 3	A 88	LA ICK PEN 3 XE	B 76	MS 56 15	E 113
IS 8	E 117	KSK 4	A 88	LA ICK PEN 8 F 05	B 75	MS 58 5	E 113
IS 53	A 174	KSK 5	A 88	LA ICK PEN 8 W 05	B 75	MS 58 7	E 113
ISAB 3 A	E 98	KSK 6	A 88	LA ICK PEN 16 W 12	B 75	MS 58 15	E 113
ISAB 3 B	E 99	KSK 7	A 88	LA ICK PEN 16 W 12 A	B 75	MS 84 4	E 113
ISAB 3 C	E 99	KSK 8	A 89	LA ICK PEN 18 W 12	B 75	MS 183 7	E 113
ISAB 4 A	E 98	KSK 9	A 89	LA ICK PEN 38 W 12	B 75	MS 183 25	E 113
ISAB 4 B	E 99	KSK 10	A 89	LA ICK PRO 25 F 12	B 75	MS 183 35	E 113
ISAB 4 C	E 99	KSK 11	A 89	LA LED 40 x 30	B 63	MS 184 7	E 113
ISAB 5 B	E 99	KSK 12	A 90	LA LED 50 x 20	B 63	MS 184 25	E 113
ISAB 5 C	E 99	KTE 1	A 177	LA LED 50 x 45	B 63	MS 184 35	E 113
ISAB 6 A	E 98	KTE 2	A 177	LA LED 68	B 64	MS 510 15	E 113
ISAB 6 B	E 99	KTE R	B 60	LAM 1	D 10	MS 923 25	E 113
ISAB 6 C	E 99	LA 1 01 ...	D 5	LAM 2	D 10	MS 3518 25	E 113
ISAB 25 A	E 98	LA 1 02 ...	D 5	LAM 2 S	D 10	MS 3518 35	E 113
ISAB 25 B	E 99	LA 1 03 ...	D 5	LAM 3	D 11	MS 4016	E 113
ISAB 25 C	E 99	LA 1 04 ...	D 5	LAM 3 D	D 12	MSHV 90	E 94
ISAM 2 A	E 100	LA 1 05 ...	D 5	LAM 3 D K	D 12	MST 3	E 111
ISAM 2 B	E 100	LA 1 06 ...	D 5	LAM 3 K	D 11	MST 220	E 111
ISAM 2 C	E 100	LA 1 07 ...	D 5	LAM 4	D 13	MSTS 3	E 111
ISAM 3 A	E 100	LA 1 08 ...	D 5	LAM 4 D	D 14	MSTS 220	E 111
ISAM 3 B	E 100	LA 1 09 ...	D 5	LAM 4 D K	D 14	MSVL 50	E 94
ISAM 3 C	E 100	LA 1 10 ...	D 5	LAM 4 K	D 13	MSVL 60	E 94
ISAS 25 A	E 101	LA 2 01 230	D 7	LAM 5	D 15	MSVL 70	E 94
ISAS 25 B	E 102	LA 2 02 230	D 7	LAM 5 D	D 16	MSVL 85	E 94
ISAS 25 C	E 102	LA 2 03 230	D 7	LAM 5 D K	D 16	MSVL 100	E 93
ISAS 30 A	E 101	LA 2 04 230	D 7	LAM 5 K	D 15	SFP 005	A 187
ISAS 30 B	E 102	LA 2 05 230	D 7	LAM 6	D 17	SFP 006	A 187
ISAS 30 C	E 102	LA 2 06 230	D 7	LAM 6 D	D 18	SFP 007	A 187
ISAS 40 A	E 101	LA 2 07 230	D 7	LAM 6 D K	D 18	SFP 016	A 187
ISAS 40 B	E 102	LA 2 08 230	D 7	LAM 6 K	D 17	SFP 028	A 187
ISAS 40 C	E 102	LA 2 09 230	D 7	LAM 7	D 19	SFP 029	A 187
ISAS 50 A	E 101	LA 2 10 230	D 7	LAM 7 K	D 19	SFP 037	A 187
ISAS 50 B	E 102	LA 4	D 21	LA V 6	D 24	SFP 046	A 187
ISAS 50 C	E 102	LA 5	D 21	LA V 7	D 24	SFP 054	A 187
ISAS 60 A	E 101	LA 6	D 23	LA V 8	D 24	SFP 057	A 187
ISAS 60 B	E 102	LA 7	D 23	LA V 9	D 30	SFP 058	A 187
ISAS 60 B 25	E 102	LA 8	D 23	LA V 10	D 30	SFP 060	A 187
ISAS 60 C	E 102	LA 9	D 29	LA V 11	D 30	SFP 067	A 187
ISAS 60 C 25	E 102	LA 10	D 29	LA V 14	D 38	SFP 074	A 187
ISP 218	E 112	LA 11	D 29	LA V 15	D 38	SFP 076	A 187
ISP 220	E 112	LA 14	D 37	LA V 17	D 40	SFP 079	A 187
ISP 220 V	E 112	LA 15	D 37	LA V 18	D 40	SFP 090	A 187
ISP 247	E 112	LA 17	D 39	LA V 21	D 42	SFP 100	A 187
K 0,55 M 12	A 175	LA 18	D 39	LA V 22	D 42	SFP 106	A 187
K 1,1 M 12	A 175	LA 20	D 52	LA V 24	D 43	SFP 112	A 187
K 9 M 4	A 174	LA 21	D 41	LA V 28	D 26	SK 01	A 98
KAP 1 P	E 71	LA 22	D 41	LA V 29	D 26	SK 02	A 98
KAP 3 K	E 71	LA 25	D 51	LA V 30	D 26	SK 03	A 99
KAP 218	E 71	LA 26	D 51	LA V 31	D 32	SK 04	A 95
KAP 218 O	E 71	LA 27 K	D 20	LA V 32	D 32	SK 06	A 113
KAP 220 G	E 71	LA 28	D 25	LA V 33	D 32	SK 08	A 106
KAP 220 K	E 71	LA 29	D 25	LA V 34	D 36	SK 09	A 91
KAP 220 O	E 71	LA 30	D 25	LA V 35	D 36	SK 13 35 SA 220	A 171
KAP 247 O	E 71	LA 31	D 31	LA V HB 1	D 48	SK 13 35 SA 220 3,2	A 171
KF 5/10	C 30	LA 32	D 31	LA V HB 2	D 48	SK 13 35 SA 220 3,5	A 171
KF 5/15	C 30	LA 33	D 31	LA V HB 3	D 48	SK 15	A 111
KF 5/5	C 30	LA 34	D 35	LA V HB 4	D 28	SK 16	A 105
KGR 1	A 85	LA 35	D 35	LA V HB 5	D 28	SK 18	A 93
KGR 2	A 85	LAGI 40	D 53	LA V HB 6	D 28	SK 19	A 95
KK 1 3,96	C 29	LAGI 60	D 53	LA V HB 7	D 34	SK 20	A 101
KK 1 6,35	C 29	LAGI 80	D 53	LA V HB 8	D 34	SK 23	A 113
KK 1 12,7	C 29	LAGI 92	D 53	LA V HB 9	D 34	SK 30	A 99
KK 1 19,05	C 29	LAGI 119	D 53	LS 101	E 110	SK 31	A 105
KK 32	C 31	LA HB 1	D 47	LS 102	E 110	SK 32	A 110
KK 92	C 31	LA HB 2	D 47	LS 103	E 110	SK 33	A 61
KK 562 GS	C 30	LA HB 3	D 47	LS 104	E 110	SK 34	A 100
KL 35 40	E 89	LA HB 4	D 27	LS 105	E 110	SK 36	A 98
KL 35 50	E 89	LA HB 5	D 27	LS 106	E 110	SK 39	A 99
KL 35 75	E 89	LA HB 6	D 27	LS 107	E 110	SK 40	A 116
KL 35 100	E 89	LA HB 7	D 33	LSD 07520	E 109	SK 42	A 70
KL 35 F 2 100	E 91	LA HB 8	D 33	LSD 08910	E 109	SK 44	A 133
KL 35 F 2 125	E 91	LA HB 9	D 33	LSD 08920	E 109	SK 45	A 94
KL 35 F 2 150	E 91	LA HL 1	D 45	LSD 13510	E 109	SK 46	B 53
KL 35 F 2 175	E 91	LA HL 2	D 45	LSD 13520	E 109	SK 47	A 71
KL 35 F 2 200	E 91	LA HL 3	D 45	MD A 04	E 115	SK 48	A 106
KL 35 K 40	E 88	LAHL D 1	D 49	MD A 06	E 115	SK 49	A 74
KL 35 K 50	E 88	LA HL V 1	D 46	MD A 07	E 115	SK 50	A 52
KL 35 K 75	E 88	LA HL V 2	D 46	MD A 09	E 115	SK 51	A 93
KL 35 K 100	E 88	LA HL V 3	D 46	MD A 12	E 115	SK 52	A 108
KL 35 L 3 40	E 90	LA ICK 15 x 15 F 05	B 74	MD B 07	E 115	SK 53	A 109
KL 35 L 3 50	E 90	LA ICK 15 x 15 F 12	B 74	MD B 10	E 115	SK 56	A 78
KL 35 L 3 75	E 90	LA ICK 17 x 17 F 12	B 74	MD C 13	E 115	SK 57	A 96
KL 35 L 4 40	E 90	LA ICK 17 x 17 F 12 A	B 74	MD C 22	E 115	SK 58	A 64
KL 35 L 4 50	E 90	LA ICK 17 x 17 W 05	B 74	MLW 32	E 114	SK 59	A 92
KL 35 L 4 75	E 90	LA ICK 17 x 17 W 12	B 74	MLW 44	E 114	SK 60	A 108
KL 35 L 4 0	E 89	LA ICK 18 x 18 F 12	B 74	MLW 51	E 114	SK 61	A 116
KL 35 L 50	E 89	LA ICK 18 x 18 W 12	B 74	MRL 20	E 114	SK 63	A 94

Alphanumerical product list

art. no.	page	art. no.	page	art. no.	page	art. no.	page
SK 64	A 103	SK 126 25 TO 220	A 147	SK 410	A 64	SK 460 37,5	A 152
SK 65	A 103	SK 126 37,5	A 147	SK 411	A 61	SK 460 50	A 152
SK 66	A 80	SK 126 37,5 2 x M3	A 147	SK 412	A 68	SK 461	D 50
SK 67	A 102	SK 126 37,5 STS TO 220	A 147	SK 413	A 63	SK 463	A 62
SK 68	A 128	SK 126 37,5 TO 220	A 147	SK 415	A 133	SK 464	A 56
SK 69	A 104	SK 126 1000	A 147	SK 416	A 67	SK 466	A 62
SK 71	A 96	SK 129 ... STC	A 143	SK 417	A 66	SK 467	A 46
SK 72	A 95	SK 129 ... STIC		SK 418	A 84	SK 468	A 50
SK 73	A 96	SK 129 ... STCB		SK 419	A 103	SK 469	A 29
SK 74	A 104	SK 129 ... STS	A 143	SK 420	A 42	SK 469 ... STS	A 150
SK 75 25	A 145	SK 129 ... STIS		SK 421	A 68	SK 470	A 28
SK 75 25 STS TO 220	A 145	SK 129 ... STSB		SK 422	A 44	SK 470 25 STS	A 150
SK 75 25 TO 220	A 145	SK 130	A 81	SK 423	A 44	SK 470 30 STS	A 150
SK 75 37,5	A 145	SK 132	A 63	SK 424	A 46	SK 470 35 STS	A 150
SK 75 37,5 STS TO 220	A 145	SK 133	A 64	SK 425	A 47	SK 470 50 STS	A 150
SK 75 37,5 TO 220	A 145	SK 134	A 39	SK 426	A 49	SK 471	A 39
SK 75 50	A 145	SK 135	A 56	SK 427	A 49	SK 472	A 43
SK 75 50 STS TO 220	A 145	SK 136	A 70	SK 429	A 51	SK 473	A 34
SK 75 50 TO 220	A 145	SK 138	A 129	SK 431 1	A 172	SK 475	A 48
SK 75 75	A 145	SK 139	A 76	SK 431 2	A 172	SK 476	A 32
SK 75 1000	A 145	SK 144	A 116	SK 431 3	A 172	SK 477	A 33
SK 76 25	A 145	SK 145	A 91	SK 432	A 116	SK 478	A 29
SK 76 25 STS TO 220	A 145	SK 145 25 STC	A 146	SK 433	A 60	SK 479	A 81
SK 76 25 TO 220	A 145	SK 145 25 STS TO 220	A 146	SK 434	A 48	SK 480	A 118
SK 76 37,5	A 145	SK 145 30 STC	A 146	SK 435	A 115	SK 481	A 121
SK 76 37,5 STS TO 220	A 145	SK 145 37,5 STS TO 220	A 146	SK 436	A 51	SK 482	A 124
SK 76 37,5 TO 220	A 145	SK 145 50 STC	A 146	SK 437	A 31	SK 483	A 126
SK 76 50	A 145	SK 145 50 STS TO 220	A 146	SK 437 ... STC	A 149	SK 484	A 150
SK 76 50 STS TO 220	A 145	SK 147	A 108	SK 437 ... STC 2	A 149	SK 485	A 52
SK 76 50 TO 220	A 145	SK 148	A 101	SK 437 ... STS	A 149	SK 486	A 34
SK 76 75	A 145	SK 149	A 76	SK 437 ... STS 2	A 149	SK 487	A 126
SK 76 1000	A 145	SK 154	A 66	SK 438	A 76	SK 489	A 121
SK 78	A 93	SK 155	A 65	SK 439	A 80	SK 490	A 119
SK 79	A 106	SK 156	A 49	SK 440	D 50	SK 492	A 120
SK 80	A 108	SK 157	A 79	SK 441	D 50	SK 493	A 37
SK 81	A 58	SK 158	A 84	SK 442	A 61	SK 495	A 125
SK 82	A 109	SK 159	A 84	SK 443	A 91	SK 496	A 27
SK 83	A 113	SK 160	A 84	SK 444	A 53	SK 497	D 50
SK 85	A 66	SK 161	A 84	SK 445	A 47	SK 498	D 50
SK 86	A 109	SK 162	A 84	SK 446	A 78	SK 499	A 126
SK 88	A 107	SK 163	A 112	SK 447	A 34	SK 501	A 78
SK 89	A 111	SK 166	A 70	SK 448	A 35	SK 502	A 71
SK 90	A 69	SK 168	A 73	SK 448 20 1 x M3 L	A 151	SK 503	A 67
SK 91	A 75	SK 172	A 115	SK 448 40 2 x M3 L	A 151	SK 504	A 64
SK 92	A 59	SK 173	A 92	SK 448 60 3 x M3 L	A 151	SK 505	A 58
SK 93	A 81	SK 174	A 41	SK 450	A 47	SK 507	A 57
SK 94	A 70	SK 176	A 112	SK 451	A 130	SK 508	A 59
SK 95	A 28	SK 177	A 36	SK 452	A 36	SK 509	A 41
SK 95 15	A 148	SK 178	A 39	SK 452 20 1 x M3	A 136	SK 510	A 67
SK 95 15 SOT 32 S	A 148	SK 179	A 42	SK 452 20 2 x M3	A 136	SK 511	A 44
SK 95 15 STS SOT 32 S	A 148	SK 180	A 50	SK 452 40 2 x M3	A 136	SK 512	A 118
SK 95 25	A 148	SK 181	A 92	SK 452 40 4 x M3	A 136	SK 513	A 42
SK 95 25 1 x M2,5 1 x M3	A 148	SK 181 94 C 3 x TO 220	A 93	SK 452 60 3 x M3	A 136	SK 514	A 122
SK 95 25 2 x M3	A 148	SK 182	A 56	SK 452 60 6 x M3	A 136	SK 518	A 132
SK 95 25 SOT 32	A 148	SK 184	A 101	SK 452 80 4 x M3	A 136	SK 519	A 69
SK 95 25 STS SOT 32	A 148	SK 185	A 106	SK 452 80 8 x M3	A 136	SK 520	A 72
SK 95 25 STS TO 220	A 148	SK 185 25 STC TO 220	A 144	SK 452 100 5 x M3	A 136	SK 521	A 30
SK 95 25 TO 220	A 148	SK 185 25 STS TO 220	A 144	SK 452 100 10 x M3	A 136	SK 522	A 29
SK 95 1000	A 148	SK 185 25 TO 220	A 144	SK 453	A 45	SK 523	A 80
SK 96	A 129	SK 185 37,5 STC TO 220	A 144	SK 454	A 33	SK 524	A 74
SK 97	A 94	SK 185 37,5 STS TO 220	A 144	SK 454 20 1 x M3	A 136	SK 525 15	A 135
SK 98	A 97	SK 185 37,5 TO 220	A 144	SK 454 20 1 x M3 L	A 151	SK 525 15 ST	A 135
SK 99	A 50	SK 185 50 C TO 220	A 144	SK 454 20 2 x M3	A 136	SK 525 20 ST	A 135
SK 100	A 54	SK 185 50 STC TO 220	A 144	SK 454 40 2 x M3	A 136	SK 525 25 ST	A 135
SK 101	A 79	SK 185 50 STS TO 220	A 144	SK 454 40 2 x M3 L	A 151	SK 525 30	A 135
SK 102	A 73	SK 185 50 TO 220	A 144	SK 454 40 4 x M3	A 136	SK 525 30 ST	A 135
SK 104 ... LS	A 138	SK 187	A 110	SK 454 60 3 x M3	A 136	SK 526 30 ST	A 135
SK 104 ... STC	A 137	SK 189	A 43	SK 454 60 3 x M3 L	A 151	SK 527	A 49
SK 104 ... STIC		SK 191	A 82	SK 454 60 6 x M3	A 136	SK 530	A 83
SK 104 ... STCB		SK 193	A 72	SK 454 80 4 x M3	A 136	SK 531	A 83
SK 104 ... STS	A 137	SK 194	A 115	SK 454 80 8 x M3	A 136	SK 533	A 83
SK 104 ... STIS		SK 195	A 104	SK 454 100 5 x M3	A 136	SK 535	A 83
SK 104 ... STSB		SK 197	A 97	SK 454 100 10 x M3	A 136	SK 536	A 83
SK 105	A 133	SK 198	A 77	SK 455	A 45	SK 537	A 83
SK 106	A 43	SK 199	A 74	SK 456	A 42	SK 538	A 83
SK 107	A 92	SK 400	A 38	SK 456 20 1 x M3 L	A 151	SK 540	A 83
SK 109	A 114	SK 400 20 1 x M3 L	A 151	SK 456 40 2 x M3 L	A 151	SK 544	A 110
SK 110	A 114	SK 400 40 2 x M3 L	A 151	SK 456 60 3 x M3 L	A 151	SK 545	A 55
SK 111	A 115	SK 400 60 3 x M3 L	A 151	SK 458	D 50	SK 546	A 58
SK 112	A 128	SK 401	A 95	SK 459 ... STC	A 141	SK 547	A 43
SK 113	A 70	SK 402	A 94	SK 459 ... STIC		SK 548	A 47
SK 115	A 171	SK 403	A 96	SK 459 ... STCB		SK 549	A 40
SK 118	A 74	SK 404	A 97	SK 459 ... STS	A 141	SK 550	A 36
SK 119	A 68	SK 405	A 68	SK 459 ... STIS		SK 551	A 34
SK 120	A 65	SK 406	A 53	SK 459 ... STSB		SK 552	A 29
SK 121	A 60	SK 407	A 56	SK 459 25 2 x TO 220	A 142	SK 553	A 63
SK 124	A 104	SK 408	A 58	SK 459 25 M	A 142	SK 554	A 34
SK 125	A 129	SK 409 ... STC	A 140	SK 459 37,5 2 x TO 220	A 142	SK 555	A 74
SK 126	A 38	SK 409 ... STIC		SK 459 37,5 M	A 142	SK 556	A 111
SK 126 25	A 147	SK 409 ... STCB		SK 459 50 2 x TO 220	A 142	SK 557	A 73
SK 126 25 2 x M3	A 147	SK 409 ... STS	A 140	SK 459 50 M	A 142	SK 558	A 30
SK 126 25 STS TO 220	A 147	SK 409 ... STIS		SK 460	A 38	SK 559	A 33
		SK 409 ... STSB		SK 460 25	A 152	SK 560	A 35

Alphanumerical product list

art. no.	page	art. no.	page	art. no.	page	art. no.	page
SK 561	A 35	SK 659	B 55	SMP 515 C 20	E 108	WFK 18 G	E 19
SK 562	A 40	SK 660	B 56	STP 4	A 188	WFK 18 GK	E 19
SK 563	A 41	SK 661	D 50	STP 5	A 188	WFK 18 K	E 19
SK 564	A 41	SK 662	A 125	SU 02	A 187	WFK 25	E 20
SK 565	A 28	SK 663	A 55	SU 03	A 187	WFK 25 G	E 20
SK 566	A 35	SK 664	A 125	SU 05	A 187	WFK 25 GK	E 20
SK 567	A 48	SK 665	A 124	SU 09	A 187	WFK 25 K	E 20
SK 568	A 78	SK 666	A 46	SU 16	A 187	WFK 35 012	E 24
SK 569	B 54	SK 667	A 50	SU 27	A 187	WFK 35 022	E 24
SK 570	B 54	SK 668	A 53	SU 29	A 187	WFK 35 G	E 24
SK 571	B 54	SK 669	A 123	SU 32	A 187	WFK 35 GK	E 24
SK 572	B 55	SK 670	A 51	SVP 01	A 188	WFK 35 K	E 24
SK 573	A 120	SK 671	A 77	SVP 04	A 188	WFK 60 01	E 33
SK 574	A 122	SK 673	A 82	SVP 10	A 188	WFK 60 02	E 33
SK 575	A 118	SK 674	A 27	SVP 12	A 188	WFK 60 03	E 33
SK 576	A 121	SK 675	A 31	SVP 13	A 188	WFK 60 K	E 33
SK 577	B 53	SK 676	A 28	SWP 02	A 187	WFK 65	E 26
SK 578	B 54	SK 677	A 37	SWP 06	A 187	WFK 65 K	E 26
SK 579	A 80	SK 678	A 75	SWP 10	A 187	WFKF 18 015	E 31
SK 580	A 73	SK 679	A 44	SWP 15	A 187	WFKF 18 017 K	E 31
SK 581	A 37	SK 680	A 51	SWP 23	A 187	WFKF 18 032 K	E 31
SK 582	A 33	SK 681	A 119	SWP 25	A 187	WFKF 30 02	E 32
SK 583	A 77	SK 682	A 77	SWP 29	A 187	WFP 09	E 29
SK 584	B 56	SK 683	A 39	SWP 36	A 187	WFP 30 020	NEW E 21
SK 585	B 53	SK 684	A 60	SWP 40	A 187	WFP 30 020 K	NEW E 21
SK 586	A 27	SK 685	A 80	SWP 55	A 187	WFP 30 030	NEW E 21
SK 587	A 40	SK 686	A 54	SWP 57	A 187	WFP 30 030 K	NEW E 21
SK 588	A 65	SK 687	A 131	THF 104	A 159	WFP 30 045	NEW E 21
SK 589	A 123	SK 688	A 30	THF 126 11	A 158	WFP 30 045 K	NEW E 21
SK 590	B 57	SK 689	A 77	THF 126 12	A 158	WFPK 09	E 28
SK 591	A 71	SK 690	A 28	THF 126 37	A 159	WFPK 13	E 30
SK 592	B 57	SK 691	A 36	THF 129 TO 220	A 158	WFK 25	E 34
SK 593	A 126	SK 692	A 129	THF 220	A 158	WFS 09 18	E 16
SK 594	A 54	SK 693	A 30	THF 220 15	A 158	WFS 09 23	E 16
SK 595	A 62	SK 694	A 30	THF 220 17	A 158	WFS 16	E 17
SK 596	A 110	SK 695	NEW A 63	THF 220 35	A 159	WFS 18	E 18
SK 599	B 57	SK 696	NEW A 66	THF 247	A 158	WFS 34	E 23
SK 600 ... STC	A 139	SK 697	NEW A 121	THF 247 4	A 159	WFS 80	E 27
SK 600 ... STIC		SK 698	NEW A 117	THF 247 11	A 158	WFSa 30 50	E 22
SK 600 ... STCB		SK 699	NEW A 79	THF 247 14	A 159	WG 3	E 14
SK 600 ... STS	A 139	SK 700	NEW A 72	THF 247 15	A 158	WG 3 P	E 14
SK 600 ... STIS		SK 701	NEW A 119	THF 249	A 158	WGT 36	E 14
SK 600 ... STSB		SK 702	NEW A 120	THF 409 220 1	A 158	WGT 300	E 14
SK 601	A 63	SK 703	NEW A 119	THF 409 220 2	A 158	WK 3	E 14
SK 602	B 53	SK 704	NEW A 123	THF 409 SOT 32	A 158	WK 3 P	E 14
SK 609	A 131	SK 705	NEW A 124	THF 409 TO 220	A 158	WK 3/4	E 14
SK 610	A 131	SK 706	NEW A 59	THF 600	A 159	WKT 24	E 14
SK 611	A 131	SK 707	NEW A 71	THFA 1	A 162	WKT 30	E 14
SK 612	A 55	SK 708	NEW A 75	THFA 2	A 162	WKT 36	E 14
SK 613	A 62	SK 709	NEW A 57	THFA 3	A 162	WKT 85	E 14
SK 614	A 76	SK 710	NEW A 65	THFA 4	A 162	WKT 300	E 14
SK 615	B 56	SK 711	NEW A 72	THFA 5	A 162	WL 0,55	A 175
SK 616	A 27	SK DC 2 1 76 SA	A 153	THFA 6	A 163	WL 1,1	A 175
SK 617	A 127	SK DC 4 1 117 SA	A 153	THFA 7	A 163	WLF 98 ...	E 36
SK 618	B 53	SK DC 5 1 59 SA	A 154	THFA 8	A 163	WLF 5 900 ...	E 35
SK 621	A 82	SK DC 5 59 SA	A 154	THFA 9	A 163	WLFT 30 ...	E 37
SK 622	A 75	SK DC 6 1 60 SA	A 154	THFA 10	A 163	WLFT 40 023	E 38
SK 623	A 69	SK DC 7 1 117 SA	A 154	THFA 36	A 161	WLFT 88 ...	E 41
SK 624	A 57	SK DC 7 117 SA	A 154	THFK 220	A 161	WLFT 404 ... /	E 39
SK 625	A 61	SK DC 8 1 60 SA	A 153	THFK 247	A 161	WLFT 405 ... /	
SK 626	A 45	SK DC 8 60 SA	A 153	THFM	A 160	WLFT 412 ... /	
SK 627	A 67	SK DC 10 60 SA	A 153	THFM 11	A 160	WLFT 414 ...	
SK 628	A 54	SK DC 11 1 58 06 SA	A 155	THFM 20	A 160	WLFT 8926 ...	E 42
SK 629	A 69	SK DC 11 58 06 SA	A 155	THFMG	A 160	WLK 5	E 83
SK 630	A 52	SK DC 12 1 58 10 SA	A 155	THFU 1	A 165	WLK 10	E 83
SK 631	A 31	SK DC 12 58 10 SA	A 155	THFU 2	A 166	WLK 30	E 83
SK 632	A 31	SK DC 13 1 58 16,5 SA	A 156	THFU 3	A 167	WLK 120	E 83
SK 633	A 32	SK DC 13 58 16,5 SA	A 155	THFU 4	A 168	WLK DK 4	E 84
SK 634	A 37	SK DC 14 1 37 20 SA	A 156	THFU 5	A 168	WLK DK 10	E 84
SK 635	A 37	SK DC 14 37 20 SA	A 156	THFU 6	A 169	WLK DK 50	E 84
SK 636	A 38	SK DC 15 58 SA	A 157	THFU 7	A 170	WLK M 4	E 84
SK 637	A 120	SK DC 16 58 SA	A 157	UK 14 SA 220	A 171	WLK M 50	E 84
SK 638	A 118	SK DC 17 58 SA	A 157	UK 14 SA 220 3,2	A 171	WLK P	E 84
SK 639	A 122	SK DC 18 23 SA	A 157	UK 14 SA M3	A 171	WLK SK 50	E 85
SK 640	A 122	SK DC 19 23 SA	A 157	US 58 4	E 113	WLK SK M	E 85
SK 641	A 124	SKK 56	C 31	US 512 4	E 113	WLP 004	E 79
SK 642	B 58	SKK 58	C 31	WB 3	E 14	WLP 035	E 79
SK 643	B 58	SKK 510	C 31	WB 3 P	E 14	WLP 300 S	E 79
SK 644	A 59	SK LED 1	B 61	WBT 30	E 14	WLP 500	E 79
SK 645	A 57	SK LED 3	B 61	WBT 36	E 14	WLP 500 S	E 79
SK 646	A 27	SK LED 4	B 62	WBT 300	E 14	WLPF 07 05	NEW E 80
SK 647	A 52	SK LED R 65	B 59	WFC 50	E 25	WLPF 07 10	NEW E 80
SK 648	A 54	SK LED R 80	B 59	WFG 15 05	E 48	WLPF 07 20	NEW E 80
SK 649	A 53	SMP 410 A 10	E 108	WFG 15 10	E 48	WLPF 07 50	NEW E 80
SK 650	A 81	SMP 410 B 10	E 108	WFG 15 15	E 48	WLPF 07 300 S	NEW E 80
SK 651	A 81	SMP 410 C 15	E 108	WFG 15 20	E 48	WLPF 13 05	NEW E 81
SK 652	A 32	SMP 410 C 20	E 108	WFG 15 25	E 48	WLPF 13 10	NEW E 81
SK 653	A 32	SMP 415 A 15	E 108	WFG 15 30	E 48	WLPF 13 20	NEW E 81
SK 654	A 40	SMP 415 B 15	E 108	WFG 15 40	E 48	WLPF 13 50	NEW E 81
SK 655	A 55	SMP 415 C 15	E 108	WFG 15 50	E 48	WLPF 13 300 S	NEW E 81
SK 656	A 79	SMP 415 C 20	E 108	WFGH 30 ...	E 50	WLPF 23 05	NEW E 81
SK 657	A 41	SMP 515 A 15	E 108	WFGH 50 ...	E 53	WLPF 23 10	NEW E 81
SK 658	B 54	SMP 515 B 15	E 108	WFK 18	E 19	WLPF 23 20	NEW E 81

Alphanumerical product list

art. no.		page
WLPF 23 50	NEW	E 81
WLPF 23 300 S	NEW	E 81
WLPF 33 05	NEW	E 82
WLPF 33 10	NEW	E 82
WLPF 33 20	NEW	E 82
WLPF 33 50	NEW	E 82
WLPF 33 300 S	NEW	E 82
WLPK 5		E 82
WLPK 10		E 82
WP 4030 100		A 173
WP 4030 100 3		A 173
WS 3		E 14
WS 3 M		E 14
WS 3 P		E 14
WS 3/4		E 14
WSC-220		E 14
WSF 08		E 43
WSF 16		E 43
WSF 24		E 43
WSF 32		E 43
WSF 48		E 43
WSF 635		E 43
WSFS 635		E 43
WSI 220 210		E 15
WSI 220 225		E 15
WSI TO 3 PL		E 15
WSI TOP 3 235		E 15
WSI TOP 3 280		E 15
WSM-220		E 14
WST 30		E 14
WST 36		E 14
WST 85		E 14

Dear business partners

We are delighted to have been honoured by the South Westphalian Chamber of Industry and Commerce as the world market leader in South Westphalia in 2024. This award is given to companies that are characterised by sophisticated leadership, customer-centric innovation, mental internationalisation and operational excellence. The expertise, creativity and commitment of our employees are the main contributors to this success.

Patrick W. Fischer

Thomas Fischer



Safety guard for fans	D 53
Active heatsinks for processors	B 74-76
Aluminium flat-, quadrangular-, angled-, U- and T-profiles	A 187-189
Aluminium oxide wafers	E 73-74
Attachable heatsink	C 10-28
Cooling aggregates with axial fan	D 20-49
Cooling aggregates with radial fan	D 51-52
Copper heatsinks for D PAK and others	C 33-35
Die-cast heatsinks	A 173-176
Distance sleeves and spacers	E 98-107
Extruded heatsinks for DC/DC converter	A 153-157
Extruded heatsinks for lock-in retaining spring	A 118-127
Extruded heatsinks for PCB mounting	A 128-152
Fastening for mounting rail	E 88-91
Fin coolers	A 177-178
Finger shaped heatsinks	C 2-9
Fluid coolers	A 179-186
GAP-Filler, Heat conductive foam and gel foils	E 43-70
Guide rails	E 92-97
Heatsinks for BGAs	B 18-26
Heatsinks for DIL-IC, PLCC and SMD	B 65-69
Heatsinks for LEDs	B 46-64
Heatsinks for PGA	B 12-17
High-performance heatsinks	D 50
High thermoconducting graphite foils	E 35-36
Insulating caps and insulating bushes	E 118-119
Insulating clamping parts for power transistors	E 112
Kapton insulator washers	E 71
Mica wafers	E 72
Miniature cooling aggregates	D 10-19
Mounting kits for insulation of power transistors	E 111
Mounting pads	E 113-115
Mounting parts for heatsinks	E 116-117
Passive heatsinks for processors	B 70-73
Pin heatsinks	B 27-45
Retaining springs for transistors	A 158-170
Segment cooling aggregates	D 5-9
Silicone-free thermal conductive foils	E 28-34
Silicone rubber insulating material for semiconductors	E 2-15
Small heatsinks	C 29-32
Standard extruded heatsinks	A 27-117
Thermal conductive foil one-sided adhesive	E 37-38
Thermal conductive paste and thermal interface film	E 75-82
Thermally conductive adhesive	E 83-87
Thermally conductive foil both sides adhesive	E 39-42
Thermally conductive foil made of siliconelastomer	E 16-27
U-Extruded heatsinks	A 171-172
Vibration dampers and solder terminals	E 108-110

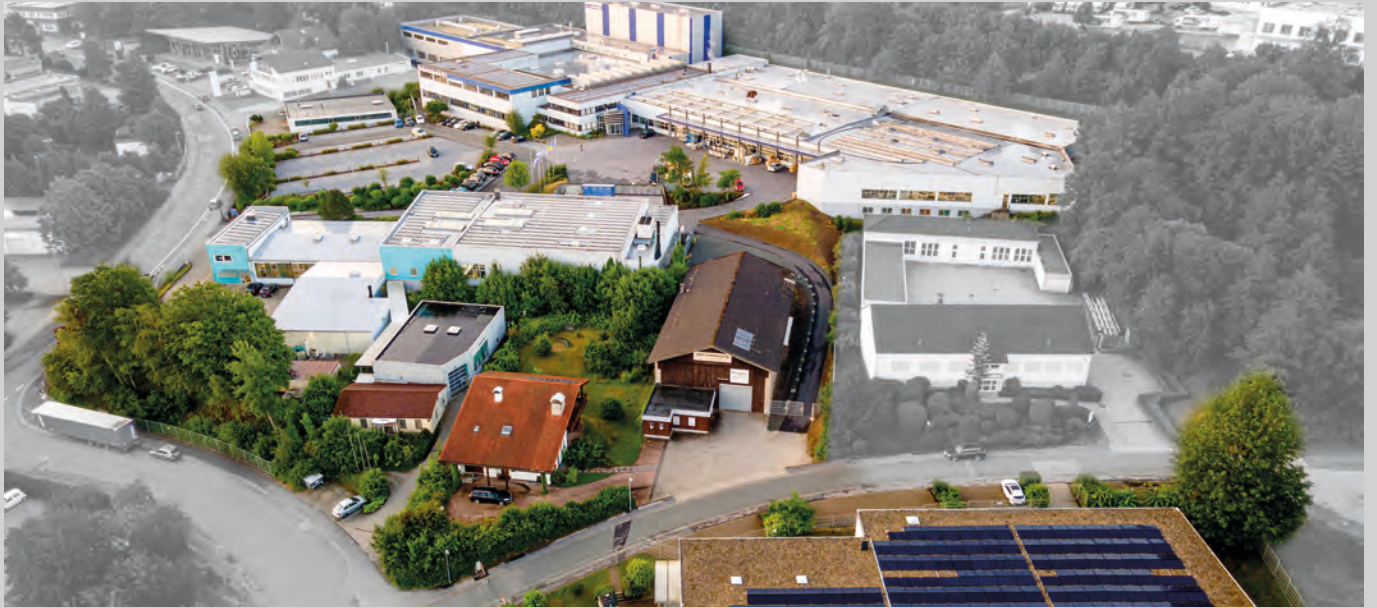

entrance area company



motivated employees



committed field service



innovative product development

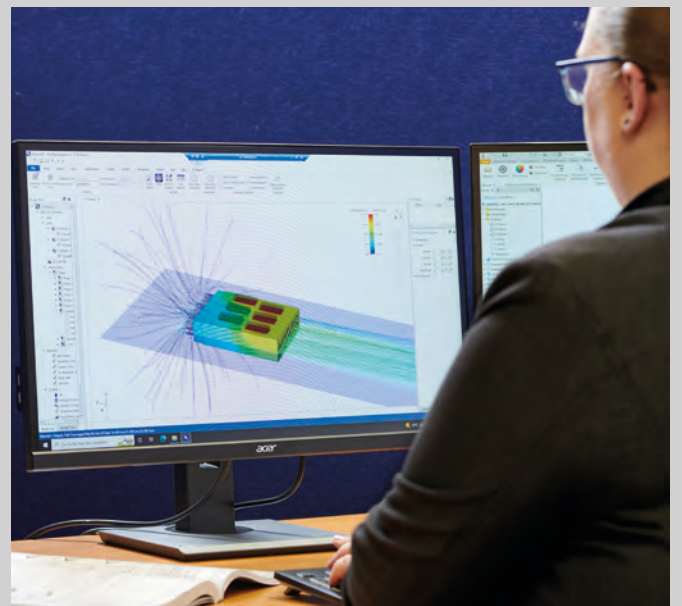



efficient special machines

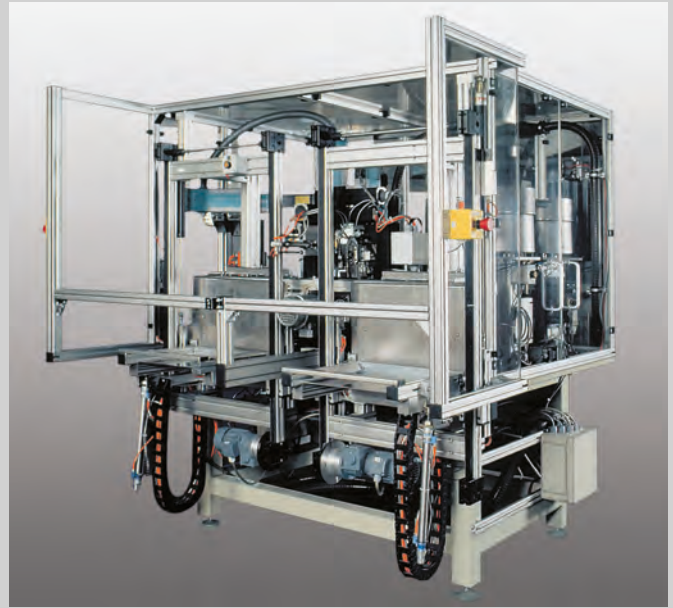

low-burr sawing technology



precise punching department



up-to-date milling technology



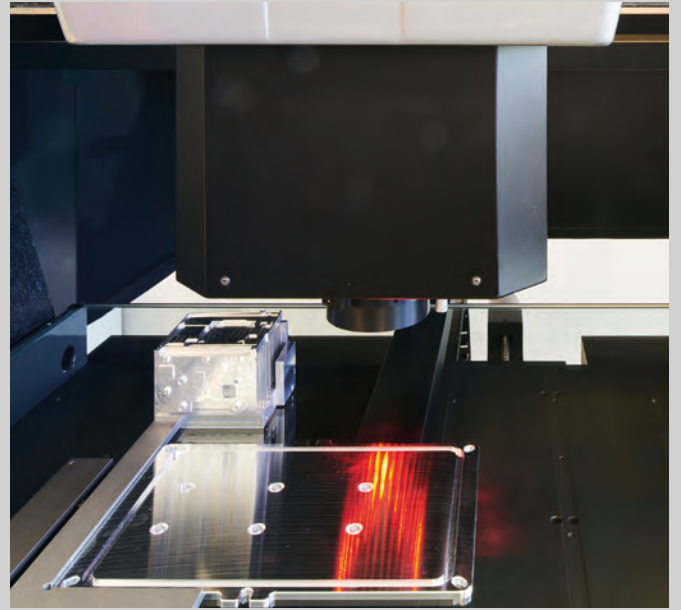

certified quality management



own tool-making department



foresighted storekeeping

Quality-Management System ISO 9001

We are certified to ISO 9001. This process-directed quality management system implies a constant focus on satisfying the demands of customers, and this is the major objective of our company.

The implementation and further development of our quality management system demonstrably ensures

- guaranteed customer satisfaction and thus the success of our company,
- compliance with customers' requirements at all times through defined processes,
- early detection and prevention of errors, and
- checking of both process effectiveness and efficiency on a regular basis together with steady improvement.

It is through constant vigilance and the provision of evidence that we deliver flawless products, which fully comply with quality requirements, that we maintain our quality certification.

In order to secure lasting company success and to meet our customers' expectations now and in the future, we define measurable objectives within the framework of our quality system, which are regularly checked and developed.

We are committed to constant measurement and improvement of our performance.

Our quality management system applies to all processes carried out by our company.

Information management norm DIN EN ISO/IEC 27001

Information security is becoming more important. For the success of our business information are essential values. Administering and protecting those has our top priority.

The information security management system to ISO/IEC 27001 considers three kinds of information: availability, confidentiality and integrity.

This information security management system is the basis for continuous monitoring and optimisation processes. It also ensures the scrupulous handling with information. A protection against attacks on the corporate network and theft is ensured.

Within the information security management system the risk evaluation such as human misconduct takes place by means of error-possibility-influence-analysis.

Environmental Management System ISO 14001

We consider protection of the environment and saving of natural resources entrepreneurial tasks of high priority.

Aware of this, our company was the first German heat-sink manufacturer to implement, the environmental management system in accordance with ISO 14001 in 1998.

Our entrepreneurial responsibility comprises preventing accidents, safeguarding against occupational diseases, designing workplaces to suit human requirements, developing products which are safe to use, saving resources and avoiding environmental impact to the maximum extent possible.

We already consider environmental compatibility in the product and process development stage. The environmental impact of our activities is documented, assessed and in a continuous improvement process reduced to a minimum.

Implementation and consistent working on and with the environmental management system is a vital process and a constant challenge but finally it will always lead to better results.

The authorised economic operator AEO-certificate

Since 1st January 2008 companies based in the European Union and involved in customs activities have been able to apply for the status of Authorised Economic Operator (AEO). The status entitles a benefit of safety-relevant custom controls and/ or simplification according to custom regulations.

The goal is here to ensure an uninterrupted global supply chain from the producer to the end user. The status of an authorised economic operator is valid in all Member States and is not limited in time.

Our company has the status AEO-C (customs simplification).

The legal requirements of an authorised economic operator are essentially the result of:

Article 5a community custom code (ZK)

Article 14a - 14x community custom code implementing provision (ZK-DVO)



You can find all current certificates at
www.fischerelektronik.de/en/company/certification





Electronica, Fair Munich

D



Embedded World, „NürnbergMesse“

D



Light + Building, „Messe Frankfurt“

D



Amper, Brno Exhibition Centre

CZ



IPS International Parts+Supply, MOC Munich

D

You can find current exhibition dates at www.fischerelektronik.de/en/latest-news/exhibition-and-events-congresses



Imprints of heatsinks and housings – your and our repro time is valuable !

Production processes:

Digital UV printing

Digital UV printing delivers high resolution printing with sharp contours through precise color application with up to 1200 dpi whereby the colors used cover the complete CMYK spectrum as well as white and silver tones. By means of a full-surface white underlay as a primer intensive colours are generated even on dark surfaces. With this printing method it is possible to print color gradients, pictures or photos. UV LEDs being activated immediately after the printing process harden the ink and ensure optimum durability of the ink on rough and smooth surfaces. Plastic materials, lacquered components and anodized or transparent passivated aluminum surfaces can be printed.

Silk screen printing

In a silk screen process the printing colour is printed on the material to be printed with help of a squeegee through a finely woven tissue. On the so-called silk a light-sensitive coating is applied which hardens by UV irradiation. Certain places which should remain translucent are covered by a film before the UV irradiation. The resulting screen is inserted in the silk printing machine and the requested colour is spread over the silk by a flood squeegee. In the next working step the silk frame is lowered over the workpiece to be printed and the colour is pressed on the material to be printed through the open spaces in the silk, the printing motive. The following hardening is processed at room temperature or by means of UV lamps.

Pad printing

The pad printing is an indirect gravure process for printing on different objects in almost any form and material. With a flood squeegee the requested colour is pulled over a cliché and then removed from the cliché with help of a doctor blade so that only a colour film remains in the recesses. The so-called pad absorbs the colour in the following working steps and presses it on the printing material in a rolling movement. The following hardening of the 2k-colours is processed at room temperature or by means of UV lamps. The pad printing allows the printing on different surface structures as well as on convex / concave curved parts due to the deformability of the pad.

Sub-elox printing

The sub-eloxal printing is a special printing process which is only used on aluminium surfaces. The special nature of this printing process is the colour that is printed in an anodised and open-pore aluminium surface. In a first production step the produced article is degreased and pickled in an anodising plant. Hereby the natural oxide layer of the aluminium is removed and a porous surface is produced. After the anodising process the requested motive is applied on the resulted surface by means of digital printing. Beforehand the aluminium workpiece is warmed up to 50 °C whereby a fast drying of the applied colour is achieved. After permanent drying of the surface the final product is compressed in a hot water bath. Due to the hot water sealing the open pores are closed and a hard oxide layer is created under which the previously applied colour is enclosed.

The order for the printing has to contain the font, font size and the exact position of the scripture together with a dimensioning by considering countersinks, etc. A requested company logo always has to be sent as a vector file. If those specifications are neglected the printing order possibly has to be rejected or it leads to a lot of additional work which is associated with additional costs.

The fulfilment of the following criteria enables a smooth order processing:

Adobe Illustrator (.ai/.eps) without continuous-tone image; used fonts converted into paths or supplied

Adobe Acrobat (.pdf) all fonts enclosed; continuous-tone images colour-separated

InDesign (.indd) spot colour or scale colours with right resolution (300 dpi colour, black and white 600 dpi); no RGB

This results in additional time requirement and therefore additional costs:

Precise testing of the data on usability by our repro department. Screen formats

(.jpg, .gif, .png) and paper patterns, stickers or anything similar are usually not suitable for creating templates in most cases.

Templates which definitively cannot be used: Imperfect copies such as paper-fax / Microsoft Office files (.doc, .xls, .ppt) can only be used for inspection or for transmitting texts.

Please always add dimensional drawings (.pdf; .dxf) to the parts to be printed. Please note as a general rule: retouching work extending beyond the standard time will be invoiced additionally at cost price.

No part of this catalogue may be reproduced or distributed without prior written consent of Fischer Elektronik. All data contained in this catalogue, in texts, illustrations, documents and descriptions are subject to copyright and the provisions of DIN ISO 16016. All rights reserved.

Explanations – references



... index area:
shows topics/categories
"current"

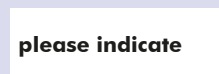
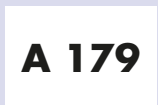

AL = aluminium natural/degreased/cutting edges not deburred
(by the metre not degreased/cutting edges not deburred)
SA = black anodised
AL = degreased aluminium
ME = clear anodised
TP = chrome-free transp. passivated

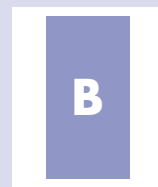
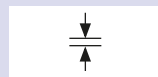
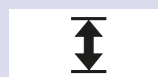
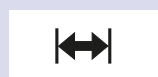
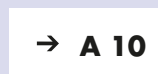

... index area:
shows topics/categories
"following"

... page number

... art. no.

... additional options

... option for surface finishing

... link to page

... length in [mm]

... height in [mm]

... hole pattern

... symbol of heatsink geometry

... thermal resistance in [K/W]

... thickness of sheet/plate

... air/speed in [m/s]

... packing (option) TR = Tape & Reel

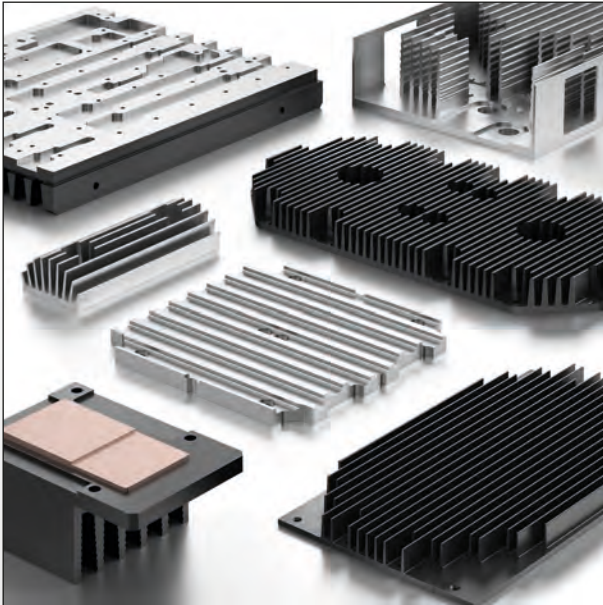

Machined heatsinks

- several hundreds of extrusion profiles available
- future orientated stockkeeping of heatsink profiles in a fully automatic honeycomb warehouse
- precise milling treatments in highest quality
- effective heat spreading by means of heatsinks with grouted copper areas
- designs and modifications according to your demand

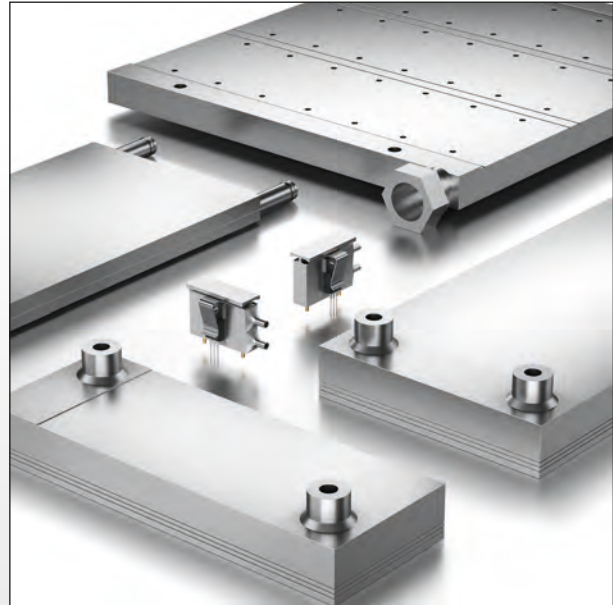

Fluid heatsinks

- fluid heatsinks for dissipation of big heat flow volumes
- compact design with internal lamella structure
- thick bottom plates for optimal heat dissipation- and U streamed versions
- water connection or mounting flange for your special application
- customized treatments and solutions

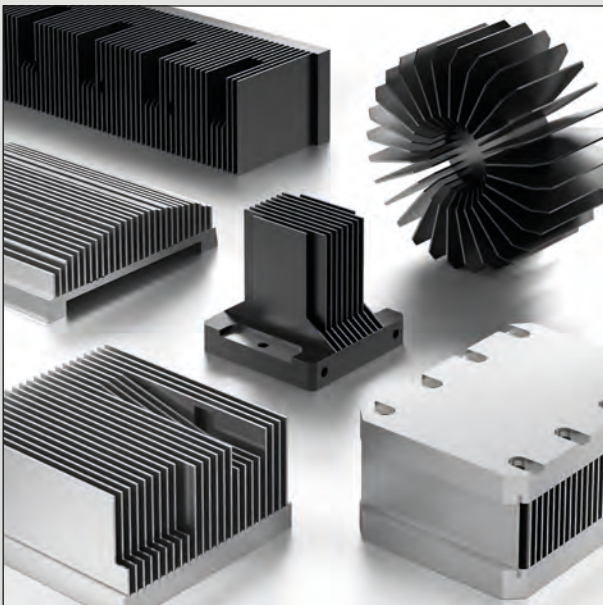

Lamella heatsinks

- compact lamella heatsinks with a big surface
- special design for forced convection
- thermotechnical optimal fitted lamellas
- precise milled flat semiconductor mounting surface
- single and double sided bottom plate made of aluminium or copper
- production according to customer specified demands

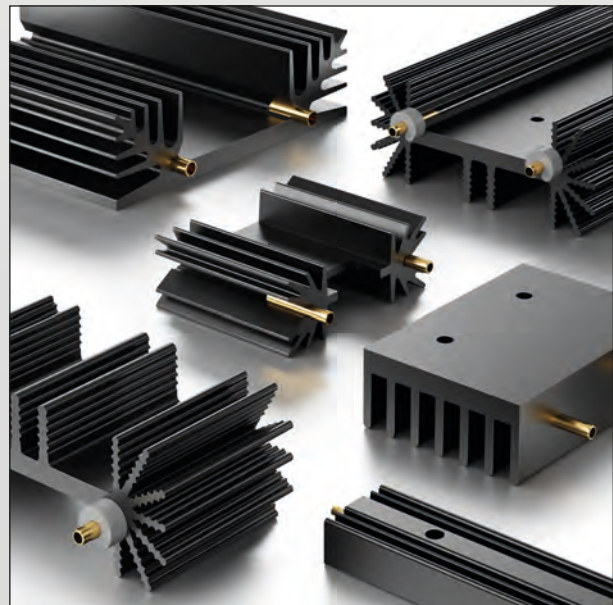

Extruded heatsinks with solder pins

- solid pressed in soldering pins and threaded bolts for a direct pcb-mounting
- for horizontal and vertical mounting position
- standard drilling patterns and transistor retaining springs for various semi-conductive elements
- soldering pins with insulation for spacing help
- variations and modifications according to drawing

Technical introduction

1. General points

In order to provide optimum performance of semi-conducting devices it is essential not to exceed the maximum junction temperature indicated by the manufacturer.

Generally this maximum junction temperature can only be maintained without exceeding it by running the device concerned at lower power outputs.

At outputs approaching the maximum ratings semi-conductor devices have to be cooled by so called heatsinks, sometimes called dissipators.

The thermal performance of these heatsinks primarily depends on the thermal conductivity of the material from which they are made, size of surface area and mass.

In addition, surface colour, mounting position, temperature, ambient air velocity and mounting place all have varying influence on the final performance of the heatsink from one application to another.

However, a figure for thermal resistance can be experimentally determined in a reliable manner and used in the equations that follow in part 2.

There are no agreed international standard methods for testing electronic cooling systems or for the determination of the thermal resistance.

Therefore the diagrams and values given in our catalogue have been determined under practical operating conditions and therefore allow the most suitable heatsink from the range to be selected.

We expressly point out that all information and data is given to the best of our knowledge and belief. The user is solely responsible for the proper use of our products and he should check their suitability for the intended application.

Fischer Elektronik do not assume any warranty, whether expressed or implied, for the suitability, function or merchantability of their products in specific or general applications, and they cannot be held liable for accidental or consequential damage due to non-observance of the above.

Furthermore Fischer Elektronik reserve the right to carry out technical modifications to their products at any time. All orders are subject to the General Sales Conditions of Fischer Elektronik.

2. The determination of thermal resistance

The thermal resistance is the parameter that is the most important in cooler selection, apart from mechanical considerations.

For determination of the thermal resistance the following equation applies:

$$\text{Equation 1: } R_{thK} = \frac{\vartheta_i - \vartheta_u}{P} - (R_{thG} + R_{thM}) = \frac{\Delta\vartheta}{P} - R_{thGM}$$

In case of an application where the maximum junction temperature is not exceeded the temperature has to be verified.

When the case temperature has been measured the use of the following equation will enable the maximum junction temperature to be calculated:

$$\text{Equation 2: } \vartheta_i = \vartheta_G + P \times R_{thG}$$

The meaning of the determinants:

ϑ_i = maximum junction temperature in °C of the device as indicated by manufacturer.
As a »safety factor« this should be reduced by 20 - 30 °C.

ϑ_u = ambient temperature in °C.
The rise in temperature caused by radiant heat of the heatsink should be increased by a margin of 10 - 30 °C.

$\Delta\vartheta$ = difference between maximum junction temperature and ambient temperature.

ϑ_G = measured temperature of device case (equation 2).

P = maximum power rating of device in [W]

R_{th} = thermal resistance in [K/W]

R_{thG} = internal thermal resistance of semiconductor device (as indicated by manufacturer)

Technical introduction

R_{thM} = thermal resistance of mounting surface. For TO 3 cases the following approximate values apply:

- | | |
|---|------------------|
| 1. dry, without insulator | 0.050 - 0.20 K/W |
| 2. with thermal compound/without insulator | 0.005 - 0.10 K/W |
| 3. Aluminium oxide wafer with thermal compound | 0.200 - 0.60 K/W |
| 4. Mica wafer (0.05 mm thick) with thermal compound | 0.400 - 0.90 K/W |

R_{thK} = thermal resistance of heatsink, which can be directly taken from the diagrams

R_{thGM} = sum of R_{thG} and R_{thM} . For parallel connections of several transistors the value R_{thGM} can be determined by the following equation:

$$\text{Equation 3: } \frac{1}{R_{thGM \text{ ges.}}} = \frac{1}{R_{thG1} + R_{thM1}} + \frac{1}{R_{thG2} + R_{thM2}} + \dots + \frac{1}{R_{thGn} + R_{thMn}}$$

The result can be substituted into equation 1.

K = Kelvin, which is the standard measure of temperature differences, measured in °C, therefore 1°C = 1 K.

K/W = Kelvin per watt, the unit of thermal resistance.

Calculation examples:

1. A TO 3 power transistor with 60 watt rating has a maximum junction temperature of 180 °C and an internal resistance of 0.6 K/W at an ambient of 40 °C with aluminium oxide wafers.

What thermal resistance is required for the heatsink?

given:

$P = 60 \text{ W}$	$R_{thG} = 0.6 \text{ K/W}$
$\vartheta_i = 180 \text{ °C} - 20 \text{ °C} = 160 \text{ °C}$ (for safety margin)	$R_{thM} = 0.4 \text{ K/W}$ (average value)
$\vartheta_u = 40 \text{ °C}$	

find: R_{thK} using equation 1

$$R_{thK} = \frac{\vartheta_i - \vartheta_u}{P} - (R_{thG} + R_{thM}) = \frac{160 \text{ °C} - 40 \text{ °C}}{60 \text{ W}} - (0.6 \text{ K/W} + 0.4 \text{ K/W}) = \underline{1,0 \text{ K/W}}$$

2. Same conditions as above but for three devices with equally distributed power ratings.

solution use

equation 1 and equation 3

$$\frac{1}{R_{thGM \text{ ges.}}} = \frac{1}{0.6 + 0.4 \text{ K/W}} + \frac{1}{0.6 + 0.4 \text{ K/W}} + \frac{1}{0.6 + 0.4 \text{ K/W}} = \frac{3}{1} \text{ W/K}$$

$$R_{thGM \text{ ges.}} = \frac{1}{3} \text{ K/W} = \underline{0.33 \text{ K/W}}$$

substitute into Equation 1 gives:

$$R_{thK} = \frac{160 \text{ °C} - 40 \text{ °C}}{60 \text{ W}} - 0.33 \text{ K/W} = \underline{1.67 \text{ K/W}}$$

With these values determined, the tabulation on page A 13 - 20 can be used to give a choice of possible heatsink profiles. Then by examination of the drawings and curves the final choice can be made.

3. A transistor with power rating of 50 W and internal thermal resistance of 0.5 K/W has a case temperature of 40 °C.

What is the actual value of junction temperature?

given:

$P = 50 \text{ W}$	$R_{thG} = 0.5 \text{ K/W}$	$\vartheta_G = 40 \text{ °C}$
--------------------	-----------------------------	-------------------------------

find: ϑ_i using equation 2

$$\vartheta_i = \vartheta_G + (P \cdot R_{thG}) \quad \vartheta_i = 40 \text{ °C} + (50 \text{ W} \cdot 0.5 \text{ K/W}) = \underline{65 \text{ °C}}$$

Thermal resistances of any profiles with forced convection

R_{thKf}	$\approx a \cdot R_{thK}$
R_{thKf}	= thermal resistance with forced convection
R_{thK}	= thermal resistance with natural convection
a	= factor of proportion

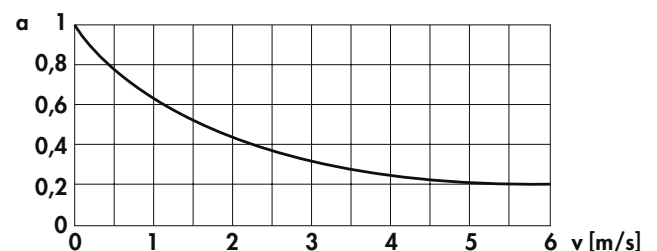

Computer based thermal simulation for optimal cooling concepts

Performance, service life and reliability of electronic semiconductor devices are significantly determined by the thermal load to which the devices are exposed. An exceeding of the maximum operating temperature leads to malfunctions. An exceeding of the permissible junction temperature leads to a destruction of the semiconductor. To make it worse there is an advancing trend in the semiconductor industry for continuous increasing integration- and power densities of electronic devices. For the solution of thermal problems the first question is which kind of heat dissipation has to be considered. For this there are different processes available: by means of free convection (passive) with different heatsink solutions, by means of forced convection (active with help of fans, cooling aggregates) or by means of fluid media (fluid cooling).

However, electronic devices and systems have many different boundary and installation conditions. Therefore the choice of the optimum thermal management is often difficult. There are surely possibilities to find the right heat dissipation concept by using the thermal resistance for calculations or by testing and verifying prototypes directly in the application, but nowadays customer specified mechanical adjustments are requested and demanded more than ever. Small mechanical post-machinings, such as additional integrated threads or drilling can be considered in the calculation with safety reserves in the temperature of the thermal resistance, but extensive modifications demand a repeated inspection of the thermal circumstances.

To facilitate the determination of passive heat dissipation concepts Fischer Elektronik offers a computer based thermal simulation as a kind of service.

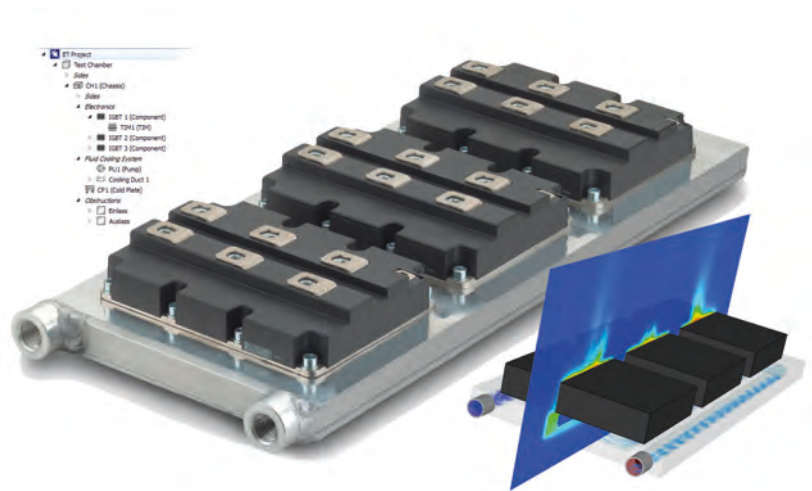

Considered factors in the thermal simulation

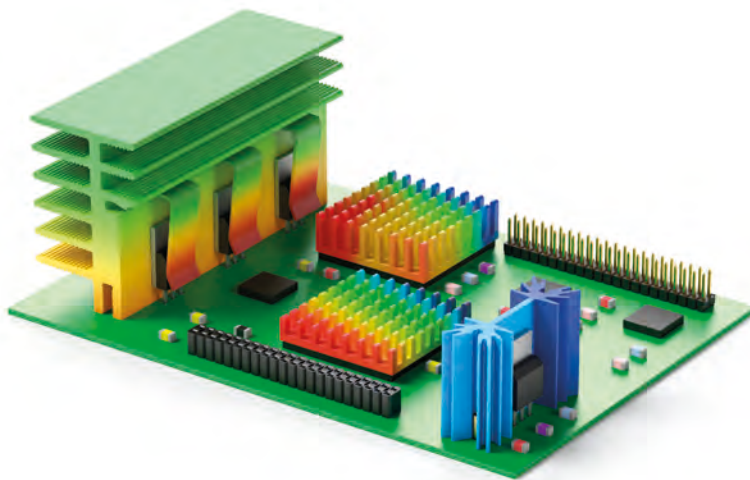

With help of the computer based thermal simulation the necessary characteristics of the cooling concept can be determined exactly. Based on physical concepts such as mass, energy and impulse the software especially considers the thermal requirements for free or forced convection. Simultaneously the system is aligned to thermal dissipation by means of fluid. Moreover the thermal simulation calculates physical effects such as thermal radiation and turbulences. The emission factor of the different surfaces also plays its role. As a result the simulation software delivers a precise cooling solution for the application and is a big help for the decision-making and interpretation of the electronic design.

Advantages of a computer based simulation

The computer based thermal simulation is already used for the prototype development. Herewith the development cycles of heat dissipation concepts is reduced considerably. Unsuitable concepts can be discarded quickly and without big costs of material. A lot of features and options of the simulation system also reduce the temporary and apparatuses efforts compared to a conventional simulation in the measurement chamber.

We will be happy to advise you in detail about the theme thermal simulation.

Remarks:

1. The values indicated in the diagrams apply only for heatsinks with black anodised surface, mounted vertically and natural convection.
Correction factors: natural surface: +10 to 15 % for horizontal mounting: +15 to 20 %
2. Heatsink profiles are extruded to European standard DIN EN 12020 (former DIN 17615).
For profiles exceeding a circumscribed circle of 350 mm, the tolerances to DIN EN 755 (former DIN 1748) apply.

Important note:

Manufacturers of certain electronic components, especially modules with a large surface area, IGBT etc., specify installation surfaces for heatsinks etc. with an flatness, which is beyond standard tolerances. Such perfect flatness can only be achieved by milling the installation surface. Furthermore, it should be noted that threaded wire inserts may be required in order to reach higher tightening torques in aluminium (e.g. Heli-Coil or similar.). Please observe the semiconductor manufacturers' information.

3. The mentioned heatsink profiles in our catalogue contain so called extrusion marks between the fins for a profile identification.
To avoid misuse the operator has to check the size and position for the mechanical treatment or placement of the components.
4. Profile extruded threaded channels are no threads conforming to standards, as they have no thread pitch.
The thread pitch is imitated by staggered webs (ribs). The customer is responsible for appropriate use.
5. Machining of our extruded and non extruded profiles conforms to requirements of DIN ISO 2768 m - unless otherwise stated.
For all ICK S types DIN ISO 2768c is valid.
6. The lengths of extruded profiles [↔] and the pin layouts [⊕] indicate only the standard range. We offer every profile cut to customer's exact length and machining requirement made to drawing or sample. We bore, countersink, mill, saw, grind and cut threads into your heat sink to meet your specific requirements. With our modern machine tools including CNC machining centres, multispindled drills (up to 26 drillings/threads at the same time) and digital milling and stamping tools plus our own "in house" tool room we are able to manufacture competitively priced prototypes as well as batch and mass produced parts with short lead times.
7. The standard material of our heatsinks is warm age-hardened aluminium alloy according to EN AW 6060 – T66 (former AlMgSi05 – F22 acc. to DIN 1748). Some heatsink profiles are also made of the alloy EN AW 6063 - T6. Our standard surface treatments are aluminium natural/degreased/cutting edges not deburred (by the metre not degreased/cutting edges not deburred) **(Al)** and black anodised **(SA)**. On request, we anodise clear natural **(ME)** or decorative in any colour that is technically possible.
8. If you cannot find a suitable profile within our range of approx. 400 profiles, 13 small heatsinks and 50 finger shaped heatsinks, we can design and produce to your requirements. Please contact us at the start of your next project so that we can work together, either directly or through our representatives. Remember that we have the ability to find the solution for "your" cooling problem.
9. Note on tolerances:
All dimensions given in this catalogue for products, items and machined parts are acc. to DIN ISO 2768 m if not otherwise stated.
Not included are items like extruded profiles, diecasts, handles, vibration dumpers etc. for which different standards apply.

Update - november 2024

The information given in this catalogue were established and examined carefully. Nevertheless, mistakes or printing errors, and especially technical modifications and updating and improvement of our products, cannot be excluded. All trade marks are recognised even if they are not specifically identified or mentioned. No identification does not imply that a product or trademark is not registered. No part of this catalogue may be reproduced or distributed without prior written consent of Fischer Elektronik. All data contained in this catalogue, in texts, illustrations, documents and descriptions are subject to copyright and the provisions of DIN ISO 16016. All rights reserved.

© Copyright Fischer Elektronik 1968 ... 2024

Technical introduction

General information

Blind holes are produced after anodising. Through holes are produced before anodising. For completely visual parts additional lacquering or adding additional mounting threads or bolts is recommended.

A part of the extruded heatsink profiles is pressed according to DIN EN 12020 (circumscribing circle <math>< 350\text{mm}</math>). For sections that exceed a circumscribed circle of 350 mm, DIN EN 755 applies. The machining tolerances are specified according to DIN ISO 2768 m.

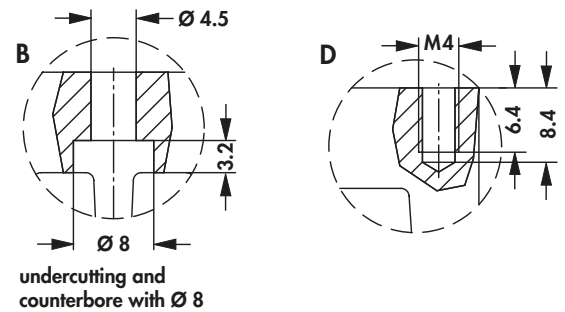
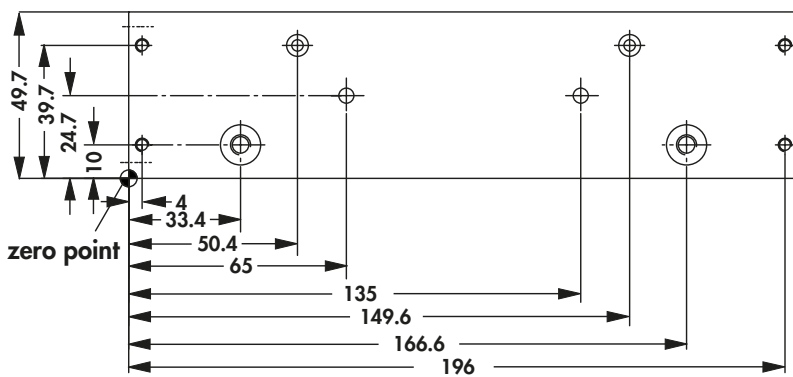
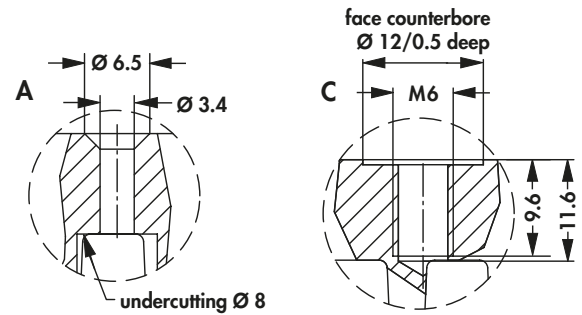
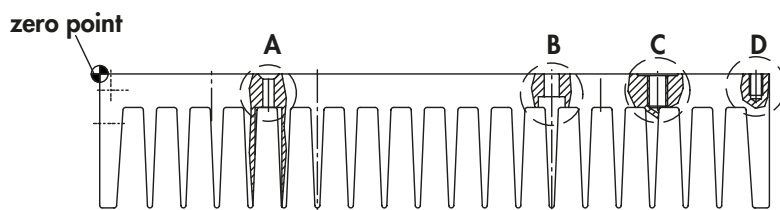
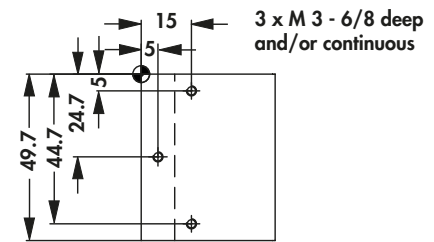
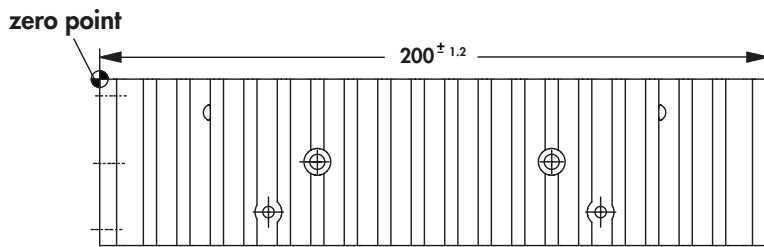

B

C

D

E

F

G

H

I

K

L

M

Information for dimensioning, shown on SK 47 general:

The deflection can be up to 0.8 mm concave, 0.2 mm convex. If a certain flatness of the bottom surface is required the bottom thickness can be decreased by a maximum of approx. 0.8 mm by means of face-milling. This situation must be taken into consideration with the bore hole depths for blind holes.

Counterbores and bore hole diameters are to be produced according to DIN 74, if not explicitly stated otherwise. The depth of thread should be calculated as follows.

Example M5:

thread: $M5 \times 1.6 \text{ mm} = 8 \text{ mm}$

core bore: $8 \text{ mm} + 2 \text{ mm} = 10 \text{ mm}$

Examples:

cutout A: Through-hole according to DIN 74 A m 3, counterbore bottom side, undercut of the fins.

cutout B: Through hole with break-through of the fins according to DIN 74 H m 4, counterbore on fin side.

cutout C: Thread M6. Depth of thread $1.6 \times 6 \text{ mm} = 9.6 \text{ mm}$, bore depth $9.6 \text{ mm} + 2 \text{ mm} = 11.6 \text{ mm}$.

Bore hole on fin base is plunged through. Face counterbore dia. 12×0.5 on bottom side.

cutout D: Blind thread M4. Depth of thread $1.6 \times 4 \text{ mm} = 6.4 \text{ mm}$, bore depth $6.4 \text{ mm} + 2 \text{ mm} = 8.4 \text{ mm}$.

Extrusion tolerances – production tolerances

There is often the problem, that the production tolerances cannot be adhered to, due to the extrusion tolerances. The two examples show how the production tolerances can be cut in half by means of suitable dimensioning (here: extension of the zero point from the outer edge to the center of the section).

When taking unfavourable extrusion tolerances into consideration a difference of 1.1 mm arises between the two types of dimensioning with respect to the axis of symmetry.

SK 82

extrusion tolerance $\pm 3.5 \text{ mm}$

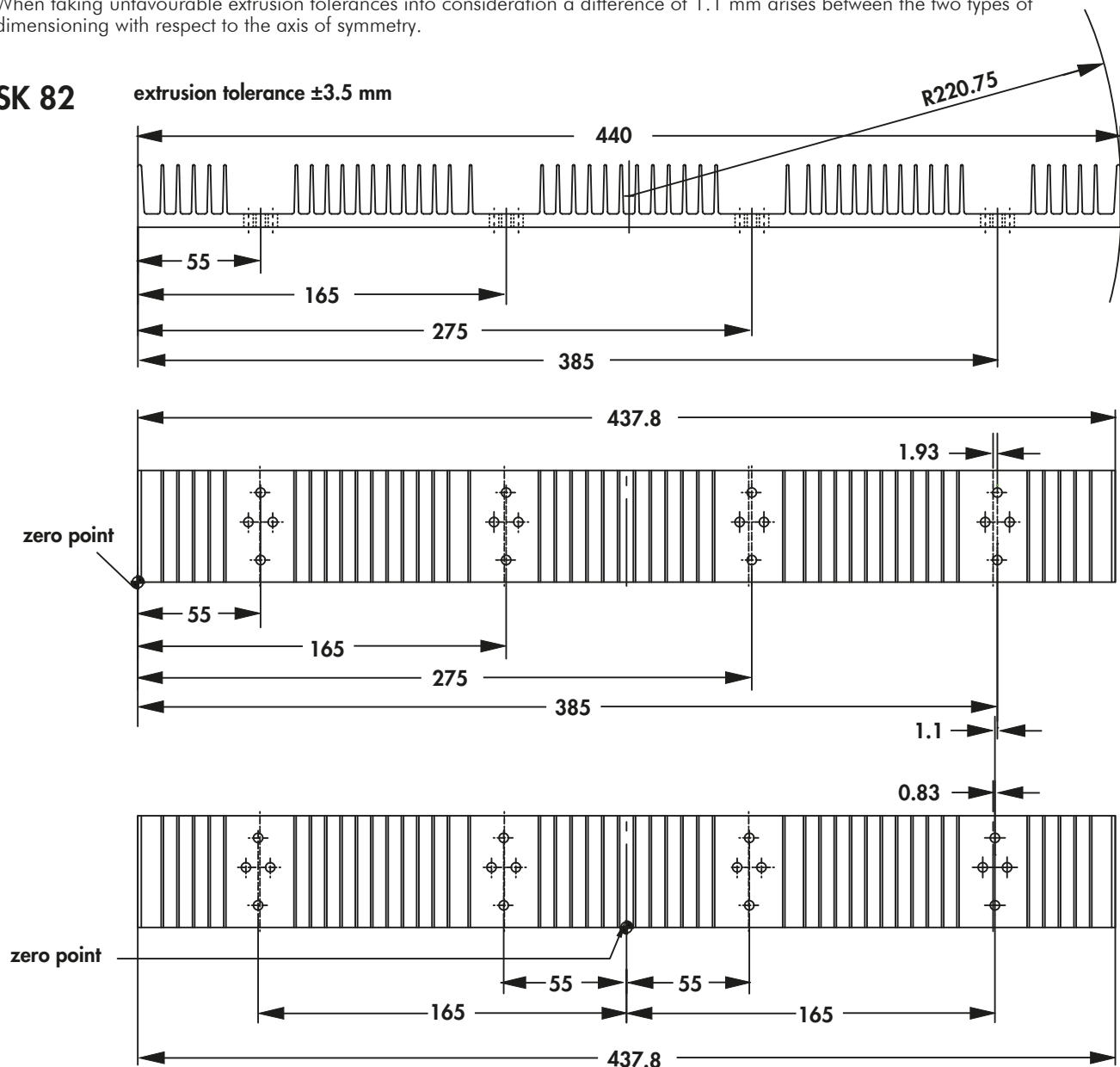

Technical introduction

SK 34

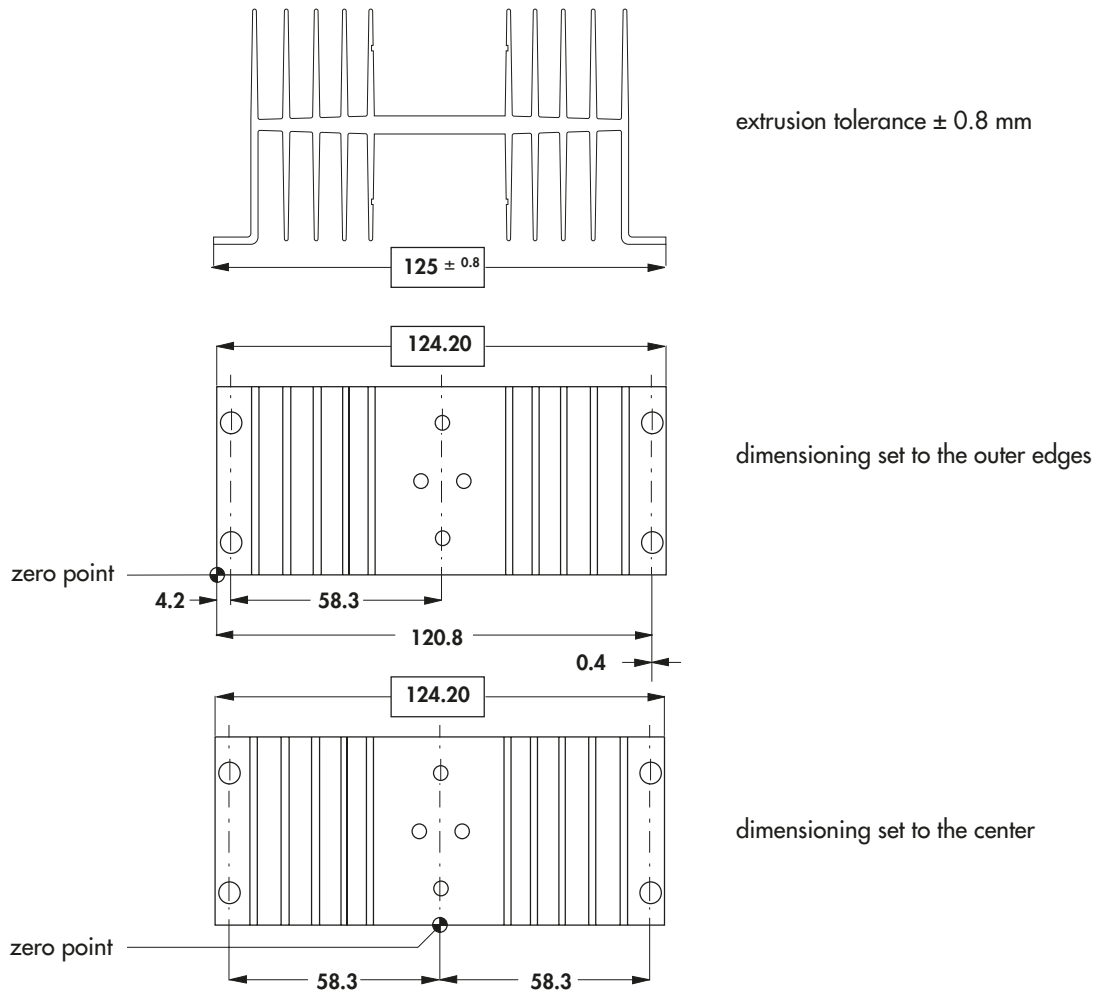

When taking unfavourable extrusion tolerances into consideration, a difference of 0.4 mm arises between the two types of dimensioning with respect to the axis of symmetry.

Milling

If, when milling heatsinks, cooling aggregates, etc., the milling tool diameter is smaller than the area being milled for production reasons, so called „milling grooves“ with steps or edges are produced (see sketch). Even if the roughness depth value for the surface is observed, it is a good idea to specify the area of the component in which no milling edges are allowed.

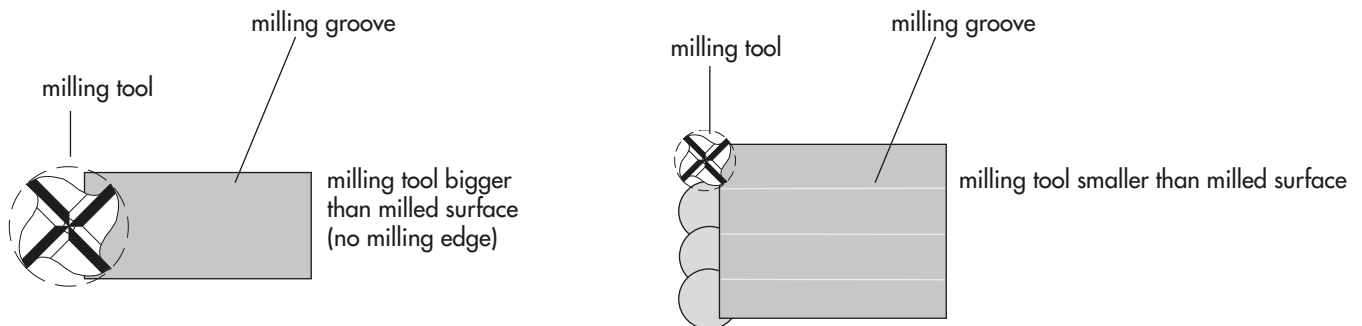

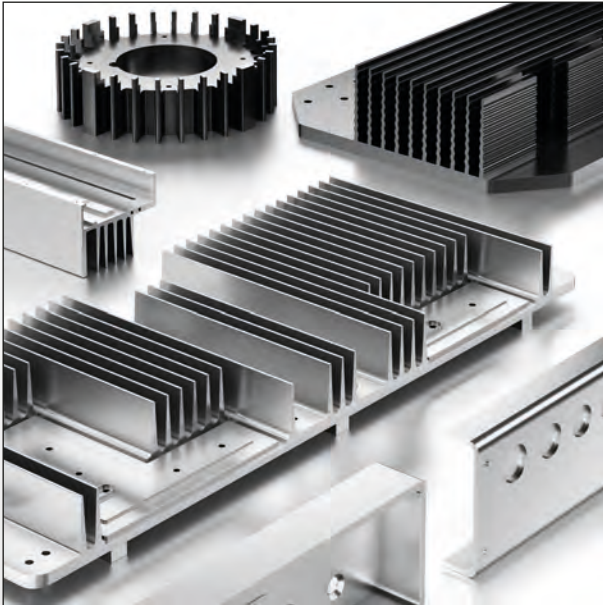

Decorative aluminium milled parts

- time-optimized, automatic stockkeeping of several hundred extruded profiles for short deliveries
- latest CNC machining centres
- precise millings for highest quality demands
- batch-optimised production processes
- special profiles according to your specific demand

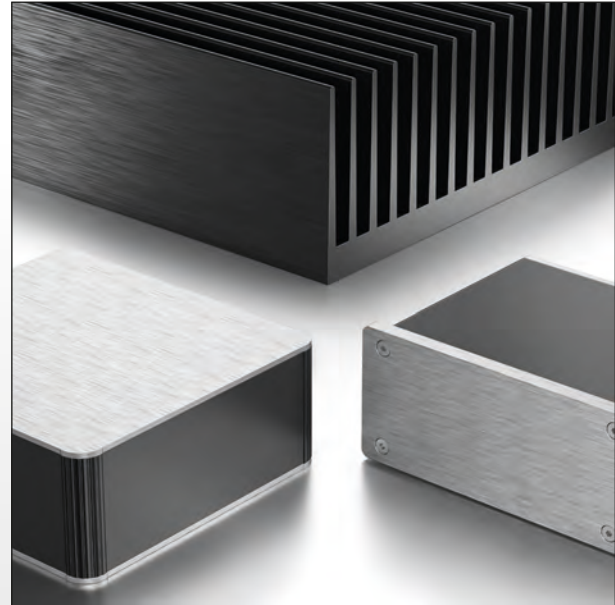

Grinding and blasting

- blasted or grinded decorative surfaces of the highest quality and grade
- homogeneous surfaces thanks to different blasting media with different grain sizes
- large selection of grinding patterns from fine to coarse
- surface design according to customised specifications or samples



Surface refinements

- corrosion resistant and decorative anodize layers
- lacquerings and durable powder coatings in all current RAL colours
- anti-glare surfaces, Nextel®-Suide Coating
- electrically conductive surfaces, chromate VI free
- prevention of clamp marks by means of special contacting systems

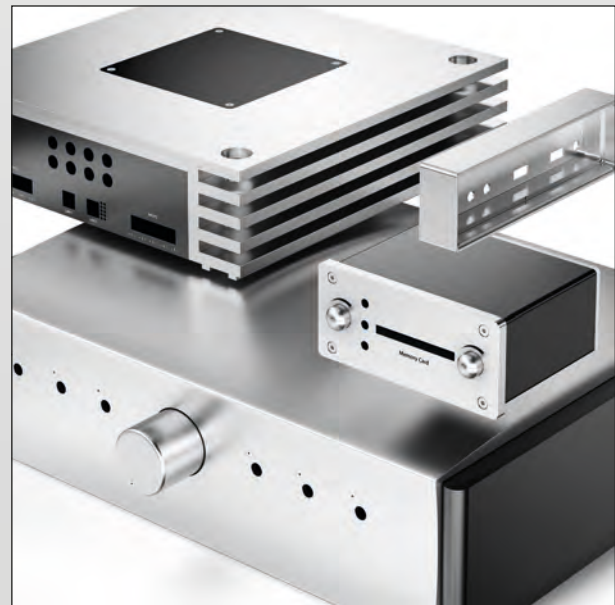

Development and construction

- competent partner with experience of more than 50 year
- Innovative product development, product-specific support by means of application engineers
- design assistance, feasibility analyses and product optimizations
- construction support and preparation of drawings

Heatsinks for decorative purposes and as visual parts

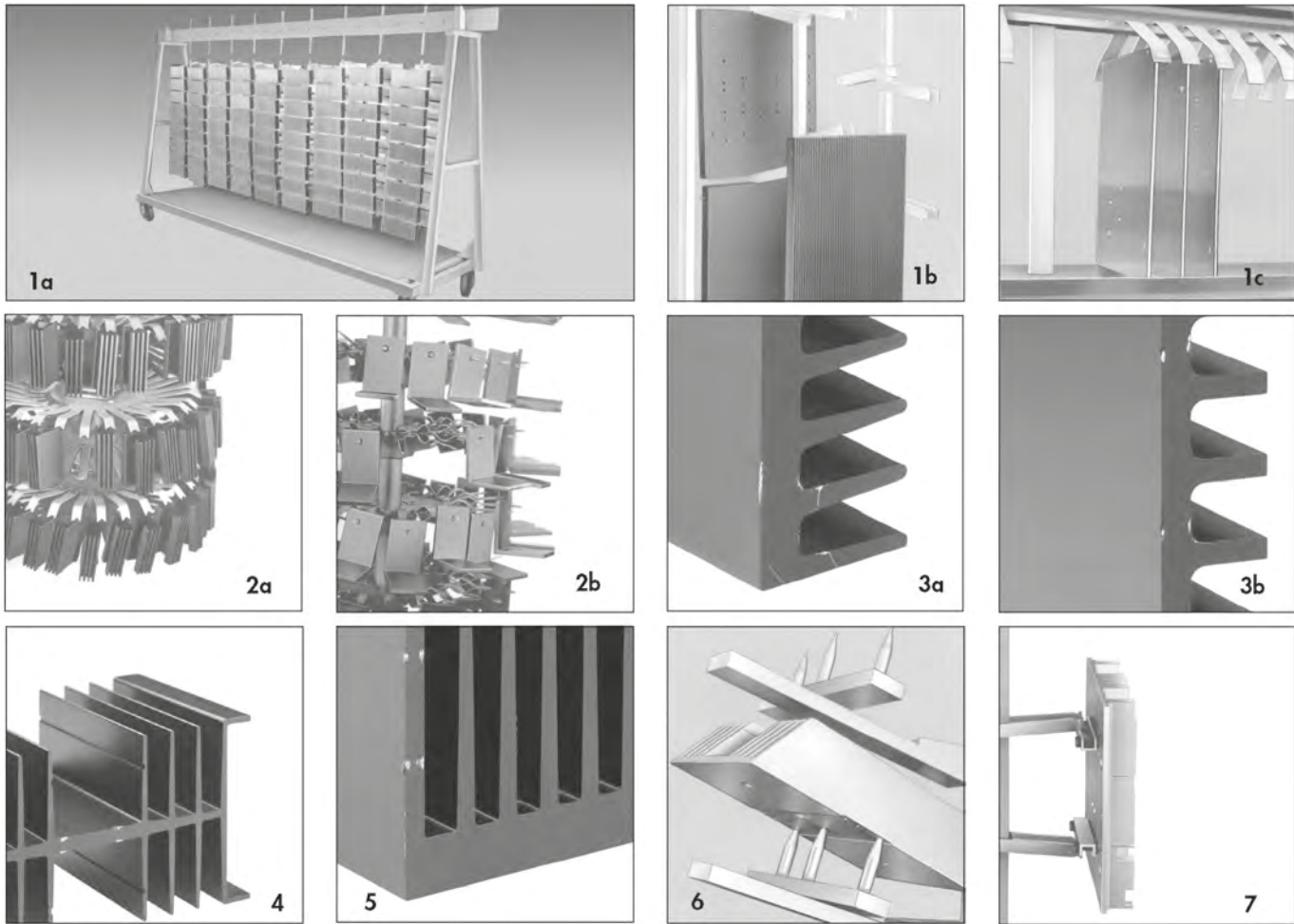

Anodising (also known as ELOXAL: **E**lectrically **O**Xidised **A**luminium) is used in many cases for decorative surface protection of aluminium. In this process, the aluminium parts to be treated are connected to the positive pole of a direct-current source (anode) in a suitable electrolyte where aluminium, in so doing, forms the negative pole (cathode). The flowing direct current now causes a migration of oxygen-containing ions, with electrically negative charge, to the anode in order to deposit the oxygen. At this point, the aluminium reacts with this oxygen, forming aluminium oxide. A non-porous, electrically insulating, abrasion free, oxide barrier, or „eloxallayer“, then develops. The development and therefore thickness of this layer can be controlled by the amount of current flow.

For process handling, secure transportation and electrical connection, the parts to be anodised must be placed on „racks“ (figure 1). As excellent electrical contact is necessary and the parts being processed must be mounted on the carrying racks in a totally secure manner a high clamping force is required especially for those large and heavy heatsinks (figure 2). This will mean that „clamp marks“ are visible. These are mere bare points in the case of small and light weight heatsinks with black anodising (figure 3) but for heavy parts the clamping pressures and current can cause deformation of the surface (figure 4). Any such deformations on large heatsinks is unavoidable and varies with each part (figure 5).

If heat sinks are used as visual parts, in other words parts whose surface must be blemish-free in appearance, it is suggested that the customer will define specific areas which should have no clamp marks. If, for technical production reasons, it is not possible to place clamps on the remaining points then consideration should be either given to the construction of separate specialpurpose frames which will allow processing (figure 6). Existing or additional threaded holes may possibly also be used for screwing on fixing angles, upon which the clamps may then be placed (figure 7). Furthermore, there is always the possibility to remove the clamp marks by hand finishing, although some slight indentation may still be visible. Alternatively, instead of using the anodising process there are various paint finishes available.

With visual parts and mouldings, both discussion of all technical details and determination of the desired design in cooperation with the manufacturer - even at the initial enquiry stage - are imperative for the smooth completion of orders to the satisfaction of the customer.

Our experts are at your disposal for all technical advice.

B

C

D

E

F

G

H

I

K

L

M

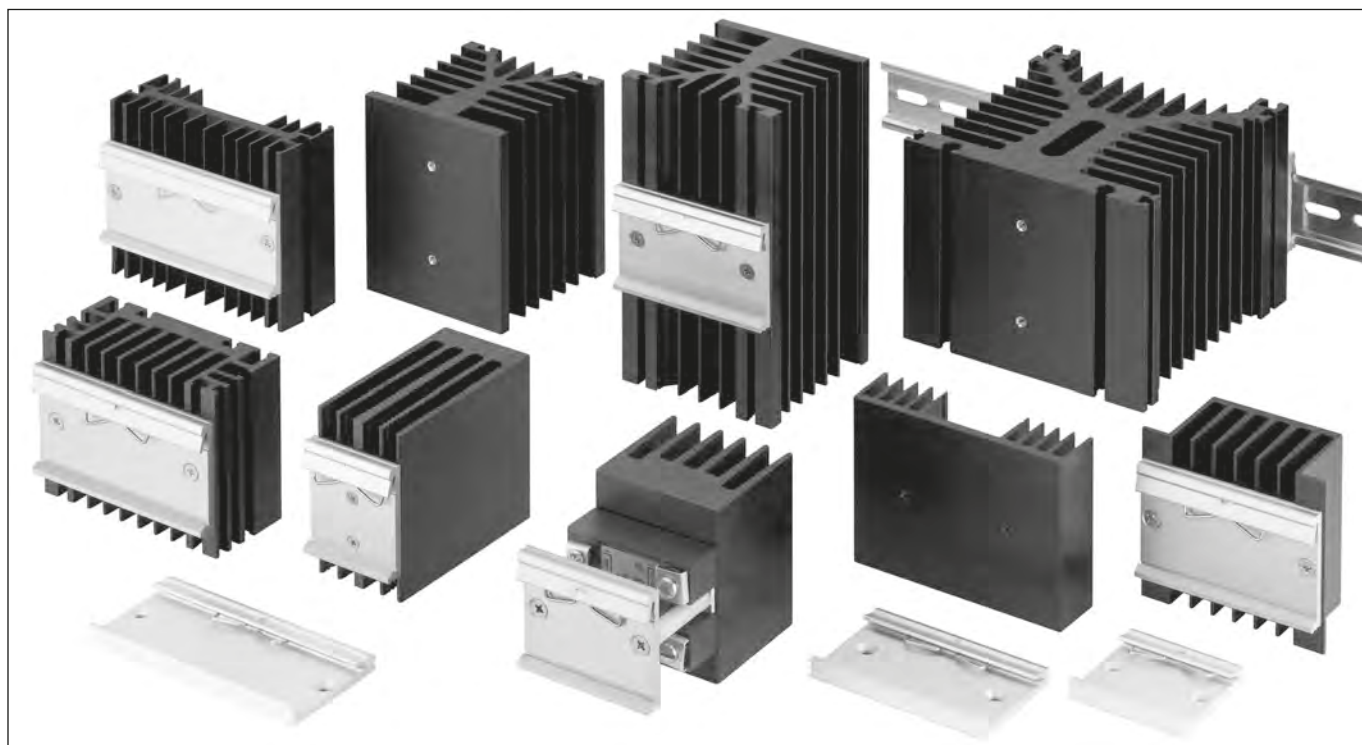

- universal clip fastening, suitable for all 35 mm mounting rails according to DIN EN 50 022, rail thickness from 1 to 2.3 mm

KL 35 ... → E 89

- fast and simple assembly of heatsinks by means of snapping them onto the mounting rail
- secure hold due to a stable extruded profile with integral stainless steel spring
- special lengths (≥ 40 mm) and drillings on request

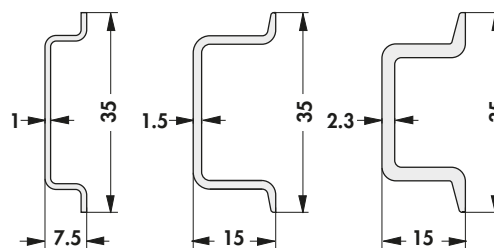
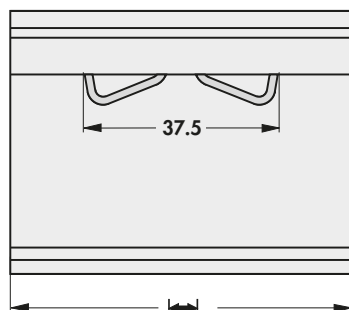
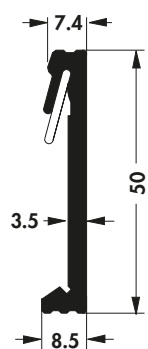

Examples of mounting rail versions suitable for KL 35

surface:

finish clear anodised

Heatsinks for solid state relays

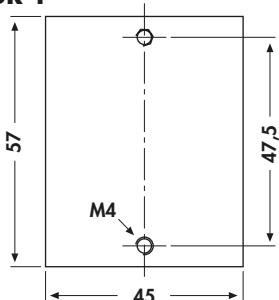
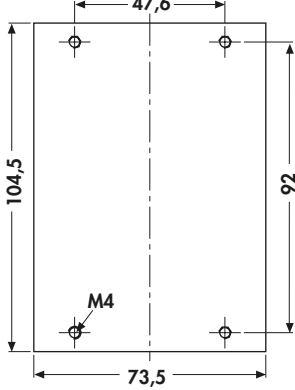
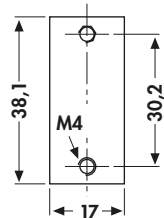
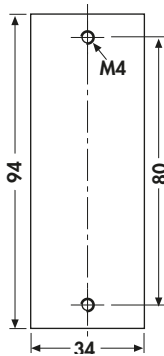
perforations	with KL 35		without KL 35
	art. no.	art. no.	art. no.
<ul style="list-style-type: none"> drilling pattern rotated by 90° as well as further drilling patterns upon request 	<ul style="list-style-type: none"> fixing of the SSR by means of screws with the help of insert nuts in the heatsink 	<ul style="list-style-type: none"> fixing of the SSR by means of screws with the help of tapped holes in the heatsink 	<ul style="list-style-type: none"> fixing of the SSR by means of screws with the help of tapped holes in the heatsink
<p>SSR 1</p> 	<p>SK 172 75 KL SSR 1</p>	<p> SK 89 75 KL SSR 1 SK 89 100 KL SSR 1 SK 111 75 KL SSR 1 SK 434 75 KL SSR 1 SK 453 75 KL SSR 1 SK 467 75 KL SSR 1 SK 507 75 KL SSR 1 </p>	<p> SK 04 75 SSR 1 SK 33 75 SSR 1 SK 111 75 SSR 1 SK 435 75 SSR 1 SK 453 75 SSR 1 SK 455 75 SSR 1 SK 467 75 SSR 1 SK 507 75 SSR 1 </p>
<p>SSR 2</p> 		<p> SK 89 100 KL SSR 2 SK 89 150 KL SSR 2 SK 176 150 KL SSR 2 SK 507 150 KL SSR 2 </p>	<p> SK 04 150 SSR 2 SK 507 150 SSR 2 </p>
<p>SSR 3</p> 	<p>SK 187 75 KL SSR 3</p>	<p>SK 111 75 KL SSR 3</p>	
<p>SSR 4</p> 	<p>SK 172 150 KL SSR 4</p>	<p>SK 455 100 KL SSR 4</p>	<p> SK 455 100 SSR 4 SK 467 100 SSR 4 </p>

B

C

D

E

F

G

H

I

K

L

M

N

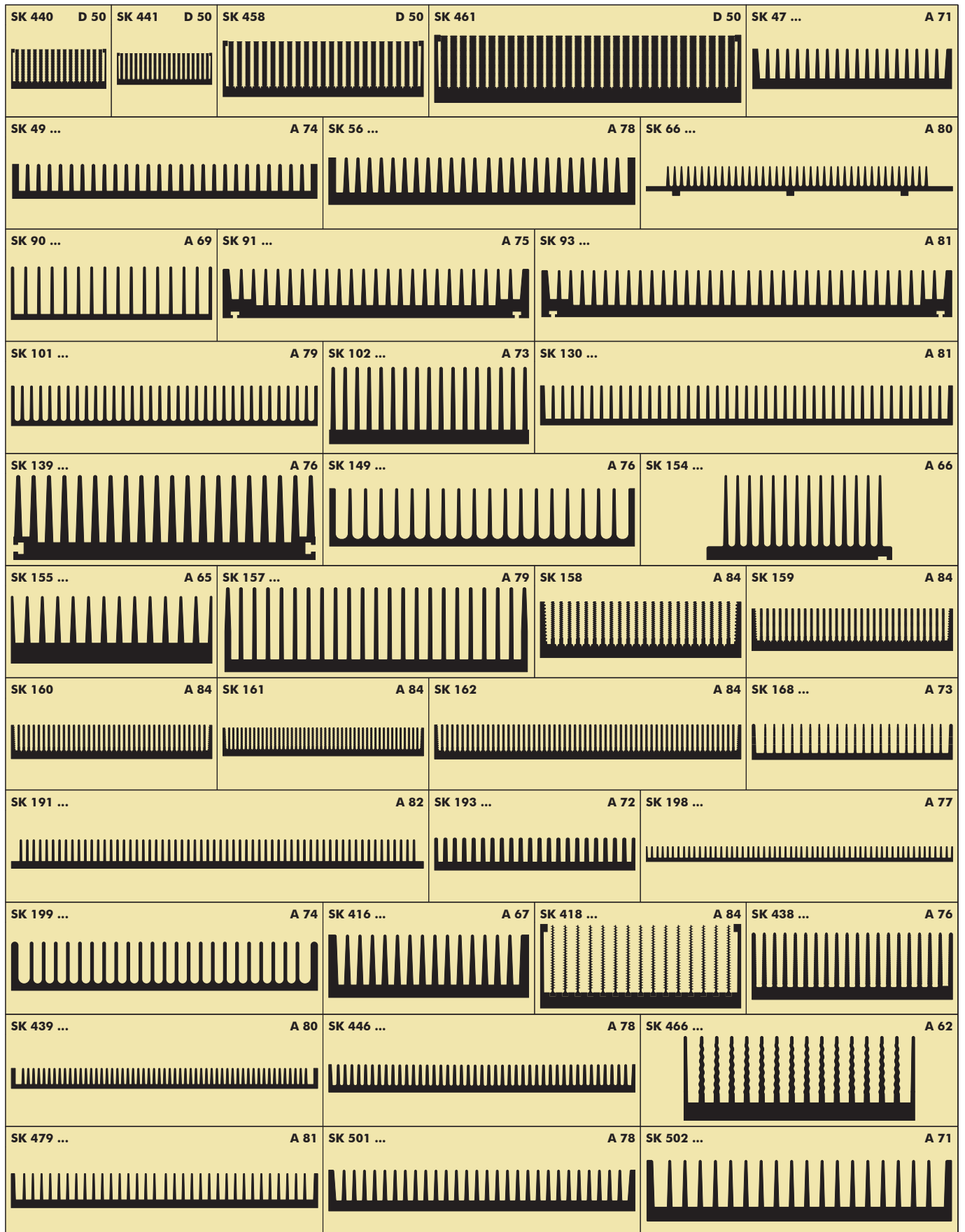

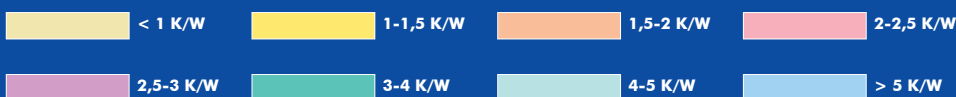
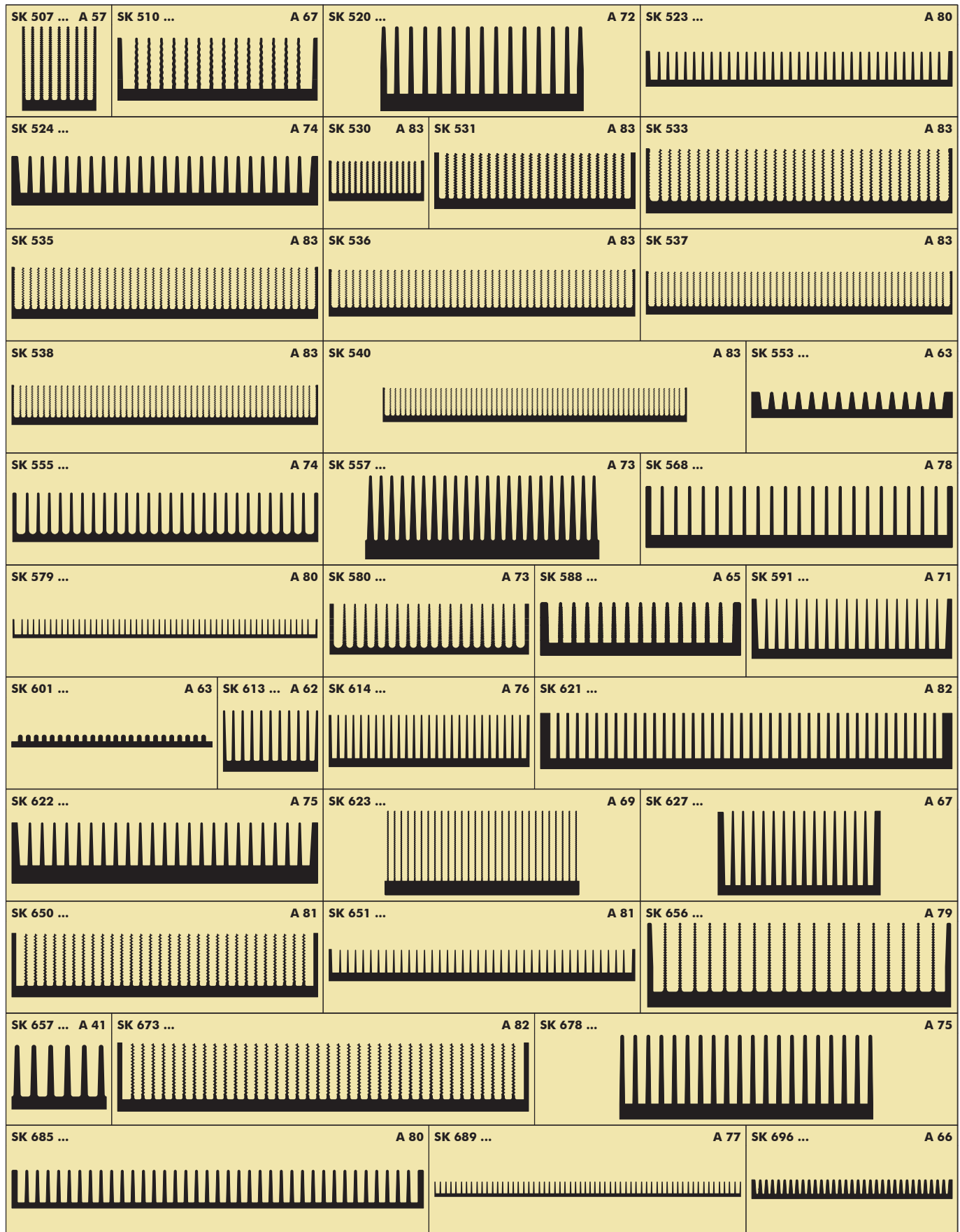

SK 699 ... A 79	SK 700 ... A 72	SK 707 ... A 71
SK 708 ... A 75	SK 710 ... A 65	SK 711 ... A 72
SK 57 ... A 96	SK 30 ... A 99	SK 53 ... A 109
SK 82 ... A 109	SK 86 ... A 109	SK 15 ... A 111
SK 163 ... A 112	SK 556 ... A 111	SK 83 ... A 113
SK 109 ... A 114	SK 110 ... A 114	SK 435 ... A 115
SK 144 ... A 116	SK 698 ... A 117	KSK 7 A 88
KSK 8 A 89	KSK 9 A 89	KSK 10 A 89
KSK 11 A 89	KSK 12 A 90	SK 497 ... D 50
SK 498 ... D 50	SK 584 ... B 56	SK 590 ... B 57
SK 592 ... B 57	SK 615 ... B 56	SK 661 D 50
SK 33 ... A 61	SK 42 ... A 70	SK 58 ... A 64
SK 85 ... A 66	SK 92 ... A 59	SK 94 ... A 70
SK 113 ... A 70	SK 118 ... A 74	SK 119 ... A 68
SK 120 ... A 65	SK 121 ... A 60	SK 132 ... A 63

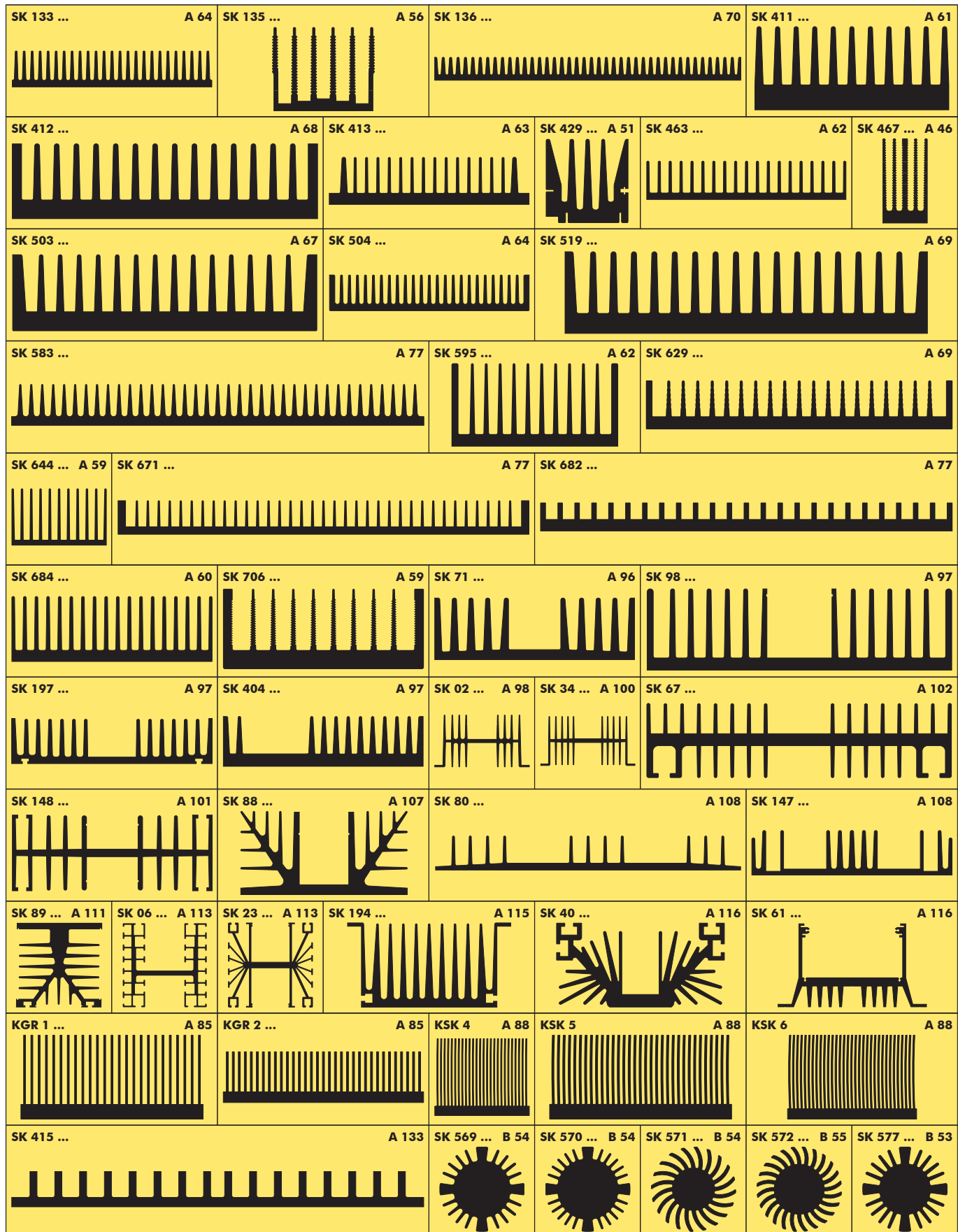

B

C

D

E

F

G

H

I

K

L

M

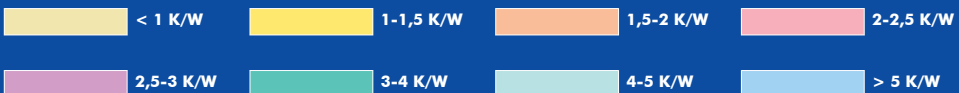

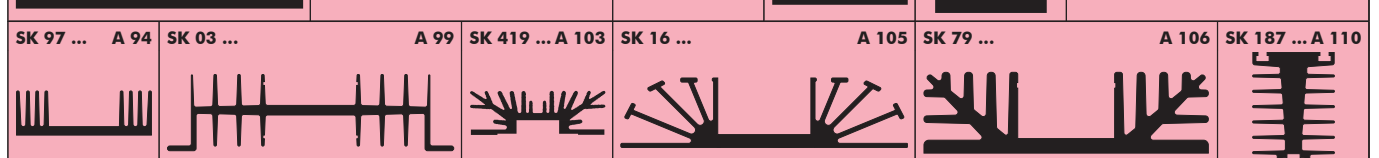
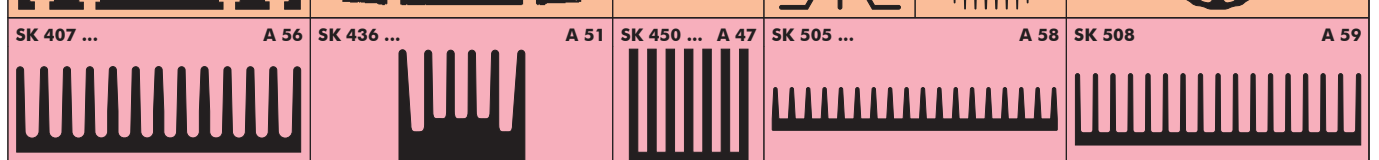
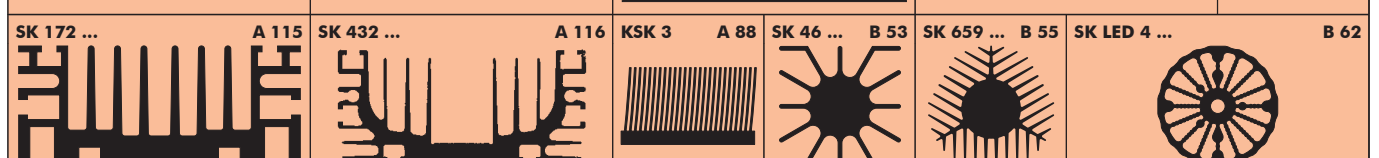
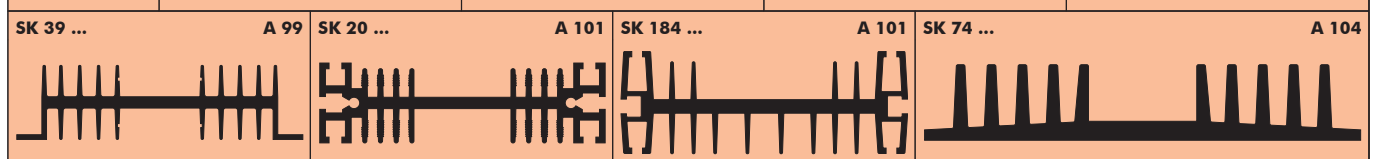
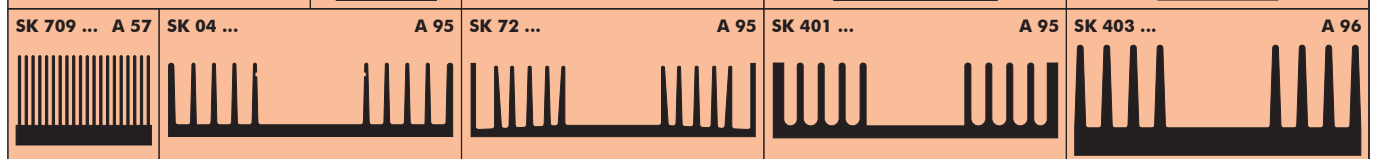
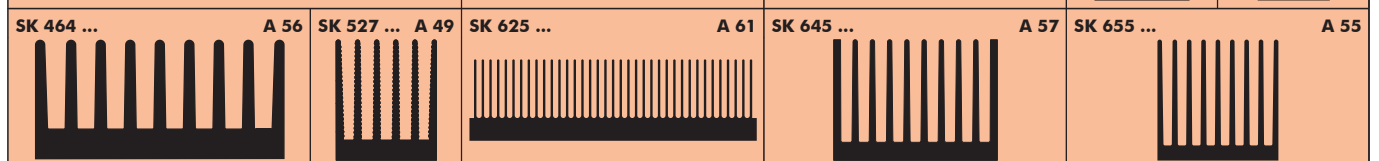
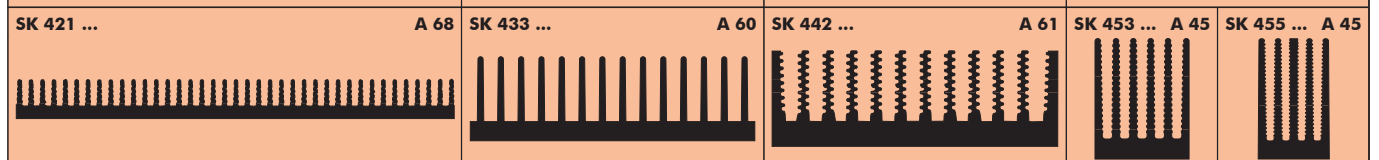
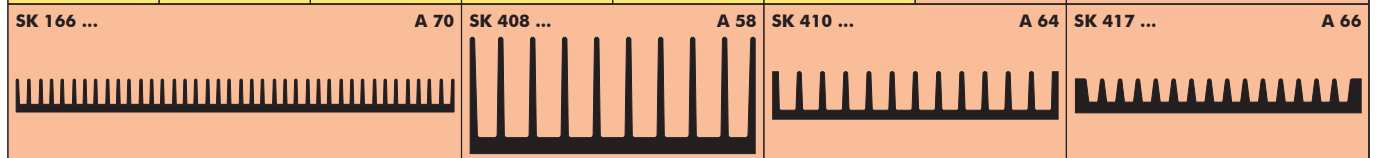

SK 111 ... A 115		KSK 1 A 87	KSK 2 A 87	SK 44 ... A 133		SK 658 ... B 54	SK 81 ... A 58	
SK 189 ... A 43	SK 405 ... A 68			SK 406 ... A 53	SK 434 ... A 48	SK 445 ... A 47	SK 628 ... A 54	
SK 666 ... A 46	SK 679 ... A 44	SK 18 ... A 93		SK 63 ... A 94	SK 402 ... A 94	SK 01 ... A 98		
SK 64 ... A 103	SK 48 ... A 106	SK 52 ... A 108		SK 32 ... A 110	SK 544 ... A 110	SK 596 ... A 110	SK 105 ... A 133	
SK 484 A 150			SK 487 ... A 126		SK 499 ... A 126	SK 514 ... A 122	SK 593 ... A 126	
SK 617 ... A 127	SK 99 ... A 50	SK 106 ... A 43	SK 134 ... A 39	SK 182 ... A 56		SK 424 ... A 46	SK 425 ... A 47	SK 426 ... A 49
SK 475 ... A 48	SK 546 ... A 58		SK 567 ... A 48	SK 594 ... A 54		SK 626 ... A 45	SK 649 ... A 53	SK 654 ... A 40
SK 663 ... A 55		SK 670 ... A 51	SK 683 ... A 39	SK 695 ... A 63		SK 19 ... A 95		SK 45 ... A 94
SK 51 ... A 93	SK 181 ... A 92	SK 36 ... A 98		SK 65 ... A 103	SK 69 ... A 104		SK 68 ... A 128	SK 112 ... A 128
SK 481 ... A 121	SK 482 ... A 124	SK 483 ... A 126	SK 489 ... A 121	SK 495 ... A 125	SK 518 A 132	SK 585 ... B 53	SK 589 ... A 123	SK 610 ... A 131
SK 618 ... B 53	SK 637 ... A 120	SK 639 ... A 122	SK 640 ... A 122	SK 641 ... A 124	SK 662 ... A 125	SK 664 ... A 125	SK 665 ... A 124	SK 669 ... A 123

B

C

D

E

F

G







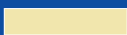

H

I

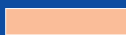
K

L

M

	< 1 K/W		1-1,5 K/W		1,5-2 K/W		2-2,5 K/W
	2,5-3 K/W		3-4 K/W		4-5 K/W		> 5 K/W

A 18

N

SK 702 ... A 120	SK 704 ... A 123	SK 705 ... A 124	SK 156 ... A 49	SK 174 ... A 41	SK 179 ... A 42	SK 180 ... A 50	SK 422 ... A 44	SK 444 ... A 53
SK 468 ... A 50	SK 472 ... A 43	SK 566 ... A 35	SK 630 ... A 52	SK 648 ... A 54	SK 485 ... A 52	SK 78 ... A 93	SK 107 ... A 92	SK 173 ... A 92
SK 185 ... A 106	SK 96 ... A 129	SK 138 ... A 129	SK 451 ... A 130	SK 490 ... A 119	SK 573 ... A 120	SK 574 ... A 122	SK 576 ... A 121	SK 611 ... A 131
SK 681 ... A 119	SK 687 ... A 131	SK 697 ... A 121	SK 703 ... A 119	SK LED 3 ... B 61	SK 95 ... A 28	SK 126 ... A 38	SK 177 ... A 36	
SK 178 ... A 39	SK 400 ... A 38	SK 420 ... A 42	SK 423 ... A 44	SK 427 ... A 49	SK 437 ... A 31	SK 447 ... A 34	SK 448 ... A 35	SK 452 ... A 36
SK 454 ... A 33	SK 456 ... A 42	SK 460 ... A 38	SK 469 ... A 29	SK 470 ... A 28	SK 471 ... A 39	SK 473 ... A 34	SK 476 ... A 32	SK 477 ... A 33
SK 478 ... A 29	SK 486 ... A 34	SK 493 ... A 37	SK 496 ... A 27	SK 509 ... A 41	SK 511 ... A 44	SK 513 ... A 42	SK 521 ... A 30	SK 522 ... A 29
SK 545 ... A 55	SK 547 ... A 43	SK 548 ... A 47	SK 549 ... A 40	SK 550 ... A 36	SK 551 ... A 34	SK 552 ... A 29	SK 554 ... A 34	
SK 558 ... A 30	SK 559 ... A 33	SK 560 ... A 35	SK 561 ... A 35	SK 562 ... A 40	SK 563 ... A 41	SK 564 ... A 41	SK 565 ... A 28	SK 581 ... A 37
SK 582 ... A 33	SK 586 ... A 27	SK 587 ... A 40	SK 616 ... A 27	SK 631 ... A 31	SK 632 ... A 31	SK 633 ... A 32	SK 634 ... A 37	SK 635 ... A 37
SK 636 ... A 38	SK 646 ... A 27	SK 652 ... A 32	SK 653 ... A 32	SK 674 ... A 27	SK 675 ... A 31	SK 676 ... A 28	SK 677 ... A 37	SK 680 ... A 51

Heatsink-chart

SK 686 ... A 54		SK 688 ... A 30	SK 690 ... A 28	SK 691 A 36	SK 693 ... A 30	SK 694 ... A 30	SK 09 ... A 91	SK 59 ... A 92
SK 145 ... A 91		SK 443 ... A 91	SK 31 ... A 105	ICK ... B B 65	ICK ... H B 65	ICK ... L B 65	SFP A 187	SK 75 A 145
SK 95 A 148		SK 115 ... A 171	SK 125 ... A 129	SK 126 A 147	SK 431 ... A 172	SK 480 ... A 118	SK 492 ... A 120	SK 512 ... A 118
SK 609 ... A 131		SK 638 ... A 118	SK 692 ... A 129	SK 701 ... A 119	SK LED 1 ... B 61	STP A 188	SU A 187	SVP A 188
SWP A 187		UK 14 SA ... A 171						

B

C

D

E

F

G

H

I

K

L

M

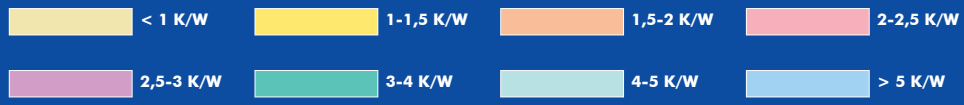

N

A

B

C

D

E

F

G

H

I

K

L

M

N

Heatsinks

Hole pattern

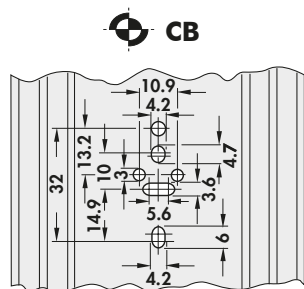

CB = TO 3 + SOT 9 + TO 66 + SOT 32 at \leftrightarrow 37.5 mm oblique drilling

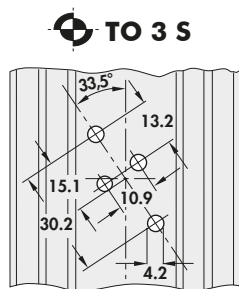

TO 3 oblique drilling for \leftrightarrow 37.5 mm

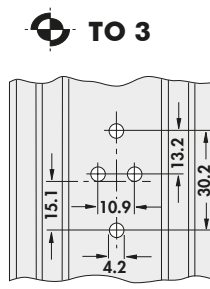

TO 3 exceeding \leftrightarrow 50 mm

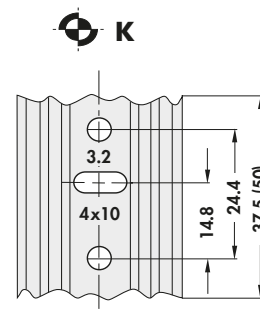
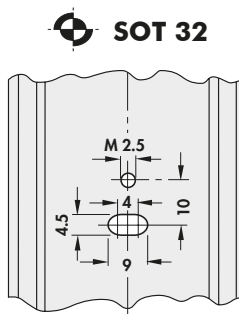
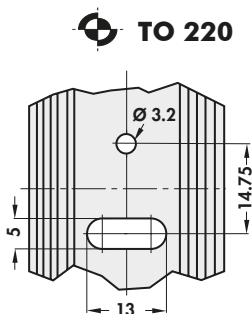

SOT 32 / TO 220 exceeding \leftrightarrow 37.5 mm

Standard hole pattern are processed as complete pin layouts, centered on the length of the heatsink. Other positions of the pin layout on the heatsink, multiple drillings or changes of the drillings are processed according to customer's requirements.

For heatsinks exceeding \leftrightarrow 75 mm standard hole pattern can be supplied in multiple design.

Fixing slots

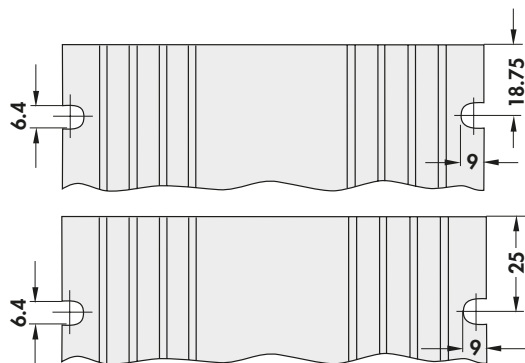

\leftrightarrow [mm]	number of fixing slots
37.5	2
75	4

\leftrightarrow [mm]	number of fixing slots
50	2
100	4

Heatsinks with the following shape **JH HL** and a standard hole pattern have these fixing slots as part of the serial production.

Order example

SK 01	50	SA	TO3
profile	length	surface	pin layout

Surface treatment for heatsinks with standard drilling: black anodised (SA).

Aluminium natural/degreased/cutting edges not deburred (by the metre not degreased/cutting edges not deburred) (AL) and clear natural anodise (ME) on request.

Assignment table of transistor heatsinks

B

C

D

E

F

G





H

I







K

L

M

	TO 3 	TO 66 	SOT 9 	TO 220 	SOT 32 
extruded heatsink	SK 01 SK 02 SK 03 SK 04 SK 05 SK 07 SK 08 SK 14 SK 16 SK 18 SK 19 SK 20 SK 21 SK 30 SK 31 SK 34 SK 36 SK 39 SK 45 SK 48 SK 51 SK 52 SK 53 SK 60 SK 63 SK 67 SK 69 SK 71 SK 72 SK 73 SK 74 SK 78 SK 79 SK 80 SK 88 SK 97 SK 122 SK 124 SK 147 SK 148 SK 185 SK 195 SK 197 SK 401 SK 402 SK 404	SK 01 SK 02 SK 03 SK 04 SK 05 SK 07 SK 08 SK 14 SK 16 SK 18 SK 19 SK 20 SK 21 SK 30 SK 31 SK 34 SK 36 SK 39 SK 45 SK 48 SK 51 SK 52 SK 53 SK 60 SK 63 SK 69 SK 71 SK 72 SK 73 SK 74 SK 78 SK 79 SK 80 SK 122 SK 147 SK 148 SK 185 SK 195 SK 197 SK 401 SK 402 SK 404	SK 01 SK 02 SK 03 SK 04 SK 05 SK 07 SK 08 SK 14 SK 16 SK 18 SK 19 SK 20 SK 21 SK 30 SK 31 SK 34 SK 36 SK 39 SK 45 SK 48 SK 51 SK 52 SK 53 SK 60 SK 63 SK 69 SK 71 SK 72 SK 73 SK 74 SK 78 SK 79 SK 80 SK 122 SK 147 SK 148 SK 185 SK 195 SK 197 SK 401 SK 402 SK 404	SK 09 SK 59 SK 64 SK 145	SK 01 SK 02 SK 03 SK 04 SK 05 SK 07 SK 08 SK 09 SK 14 SK 16 SK 18 SK 19 SK 20 SK 21 SK 30 SK 31 SK 34 SK 36 SK 39 SK 45 SK 48 SK 51 SK 52 SK 53 SK 60 SK 63 SK 65 SK 69 SK 71 SK 72 SK 73 SK 74 SK 78 SK 79 SK 80 SK 122 SK 147 SK 148 SK 185 SK 195 SK 197 SK 401 SK 402 SK 404

Assignment table of transistor heatsinks

	 TO 3	 TO 66	 SOT 9	 TO 5	 TO 247	 TO 3 P
extruded heatsink with solder pin					SK 126 SK 145 SK 400 SK 437 SK 448 SK 459 SK 460 SK 600	SK 104 SK 129 SK 400 SK 409 SK 448 SK 456
extruded heatsink	WP 4030				SK 452 SK 484	SK 452 SK 484
set-up/clip-on heatsinks	AKK 127 AKK 191				FK 243 FK 245 FK 271 FK 272 FK 273 FK 274 FK 275 FK 276 FK 277 FK 278 FK 279 FK 280 FK 281 FK 282	
finger-shaped heatsinks	FK 201 FK 202 FK 205 FK 206 FK 207 FK 208 FK 223 FK 234 FK 236 FK 254 1 FK 318 FK 318 1	FK 201 FK 202 FK 205 FK 206 FK 207 FK 208 FK 223 FK 234 FK 236	FK 201 FK 202 FK 205 FK 206 FK 207 FK 208 FK 223 FK 234 FK 236			
small heatsinks				KF 5 KK 1 KK 562 SKK		

B

C

D

E

F

G

H

I







K

L





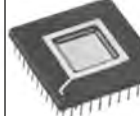

M

N

Assignment table of transistor heatsinks

	TO 218 	TO 220 	SOT 32 	DIL 	PLCC 	P-SIP 	PGA/BGA 
U-heatsinks		ICK 35 SK 431 UK 14					assignment table → B 2 - 11
extruded heatsink with solder pin	SK 145 SK 400 SK 437 SK 448 SK 459 SK 460	SK 75 SK 76 SK 104 SK 129 SK 145 SK 185 SK 409 SK 459 SK 460 SK 600	SK 104 SK 129 SK 454 SK 469 SK 470				
extruded heatsinks	SK 126 SK 452 SK 484	SK 95 SK 126 SK 400 SK 437 SK 448 SK 452 SK 454 SK 469 SK 470 SK 484 SK 518	SK 95	ICK ... B ICK ... H ICK ... L	ICK PLCC ICK R		
set-up/clip-on heatsinks	FK 220 FK 224 FK 241 FK 243 FK 245 SK 516	FK 220 FK 224 FK 237 FK 240 FK 242 FK 243 FK 245 FK 248 FK 253 FK 255 FK 257 FK 258 FK 259 FK 260 FK 261 FK 262 FK 263 FK 264 FK 265 FK 266 FK 267 FK 268 FK 269 FK 270 SK 515				FK 224	

Assignment table of transistor heatsinks

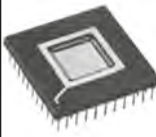
	TO 218 	TO 220 	SOT 32 	DIL 	PLCC 	P-SIP 	PGA/BGA 
finger-shaped heatsinks	FK 243 FK 245	FK 205 FK 206 FK 207 FK 208 FK 210 FK 212 FK 214 FK 216 FK 217 FK 218 FK 219 FK 222 FK 225 FK 227 FK 228 FK 229 FK 230 FK 231 FK 232 FK 233 FK 234 FK 235 FK 236 FK 238 FK 247	FK 201 FK 205 FK 206 FK 207 FK 208 FK 209 FK 210 FK 211 FK 212 FK 213 FK 214 FK 215 FK 216 FK 217 FK 218 FK 223 FK 234 FK 235 FK 236 FK 239				assignment table → B 2 - 11
small heatsinks			KK 32 KK 92				

B

C

D

E

F

G

H

I

K

L



M



Standard extruded heatsinks

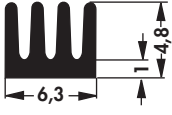
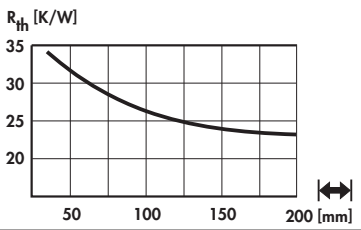

B

C

art. no.			
SK 674 ...			
please indicate:	...  37.5 50 75 100 1000 mm	... custom processing (optional) CNC = individual CNC machining WL = desired length	

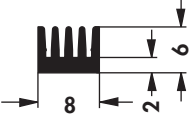
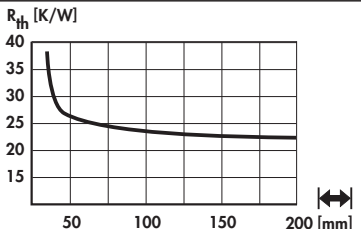

D

E

art. no.			
SK 586 ...			
please indicate:	...  37.5 50 75 100 1000 mm	... custom processing (optional) CNC = individual CNC machining WL = desired length	

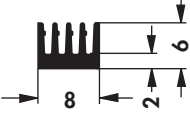
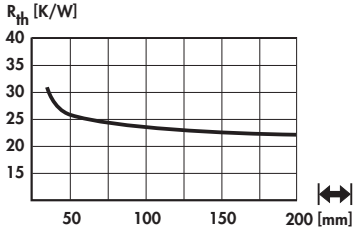

F

G

art. no.			
SK 616 ...			
please indicate:	...  37.5 50 75 100 1000 mm	... custom processing (optional) CNC = individual CNC machining WL = desired length	

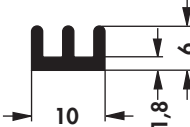
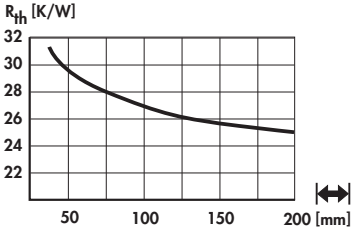

H

I

art. no.			
SK 496 ...			
please indicate:	...  37.5 50 75 100 1000 mm	... custom processing (optional) CNC = individual CNC machining WL = desired length	

K

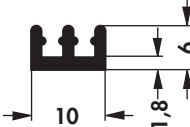
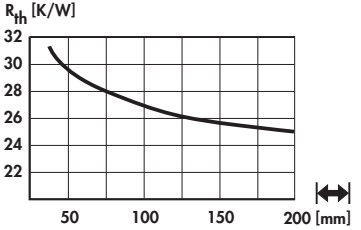
L

art. no.			
SK 646 ...			
please indicate:	...  37.5 50 75 100 1000 mm	... custom processing (optional) CNC = individual CNC machining WL = desired length	

M

N

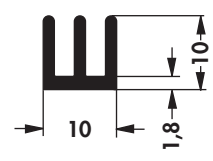
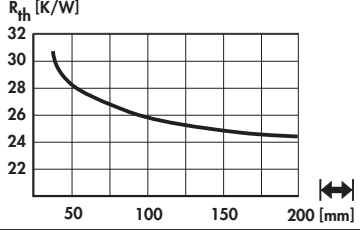
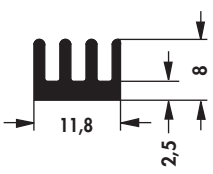
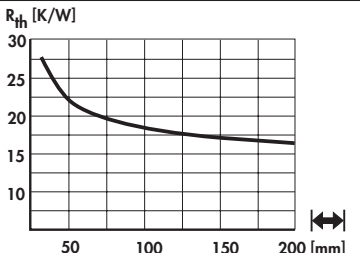
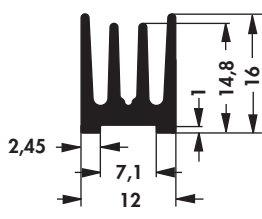
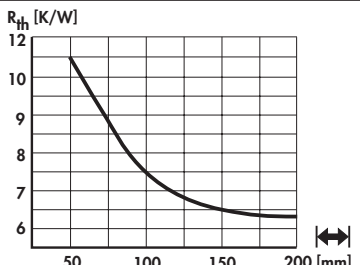
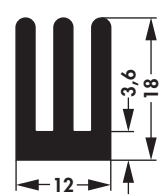
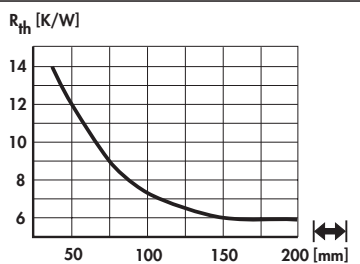
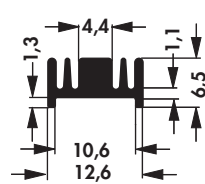
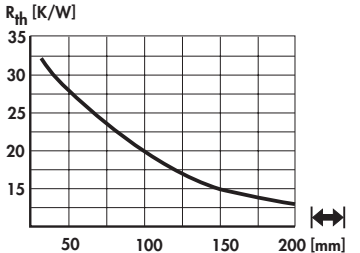

Standard extruded heatsinks

<p>art. no.</p> <p>SK 565 ...</p>		
<p>please indicate: ... \longleftrightarrow</p> <p>37.5 50 75 100 1000 mm</p>		<p>... custom processing (optional)</p> <p>CNC = individual CNC machining</p> <p>WL = desired length</p>
<p>art. no.</p> <p>SK 470 ...</p>		
<p>extruded heatsinks for PCB mounting → A 150</p>		
<p>please indicate: ... \longleftrightarrow</p> <p>25 37.5 50 75 100 1000 mm</p>		<p>... custom processing (optional)</p> <p>CNC = individual CNC machining</p> <p>WL = desired length</p>
<p>art. no.</p> <p>SK 676 ...</p>		
<p>please indicate: ... \longleftrightarrow</p> <p>25 37.5 50 75 100 1000 mm</p>		<p>... custom processing (optional)</p> <p>CNC = individual CNC machining</p> <p>WL = desired length</p>
<p>art. no.</p> <p>SK 690 ...</p>		
<p>please indicate: ... \longleftrightarrow</p> <p>25 37.5 50 75 100 1000 mm</p>		<p>... custom processing (optional)</p> <p>CNC = individual CNC machining</p> <p>WL = desired length</p>
<p>art. no.</p> <p>SK 95 ...</p>		
<p>please indicate: ... \longleftrightarrow</p> <p>15 25 37.5 1000 mm</p>		<p>... custom processing (optional)</p> <p>CNC = individual CNC machining</p> <p>WL = desired length</p>

B

C

D

E

F

G

H

I

K

L

M



N



Standard extruded heatsinks

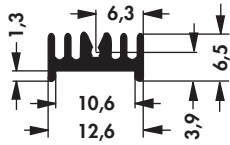
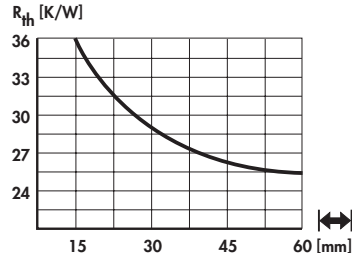

B

C

art. no.		
		
SK 522 ...		
please indicate:	...  15 25 37.5 50 1000 mm	... custom processing (optional) CNC = individual CNC machining WL = desired length

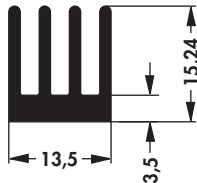
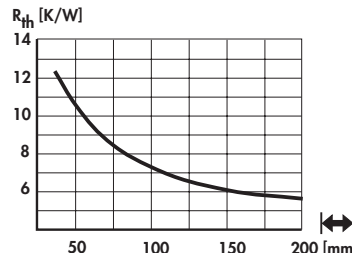

D

E

art. no.		
		
SK 469 ...	extruded heatsinks for PCB mounting → A 150	
please indicate:	...  25 37.5 75 100 1000 mm	... custom processing (optional) CNC = individual CNC machining WL = desired length

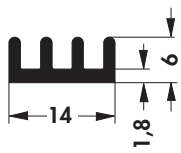
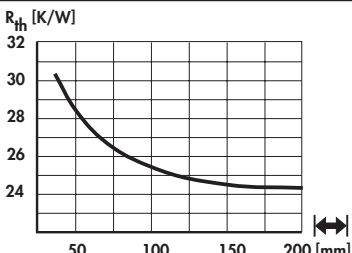

F

G

art. no.		
		
SK 478 ...		
please indicate:	...  25 37.5 50 75 1000 mm	... custom processing (optional) CNC = individual CNC machining WL = desired length

H

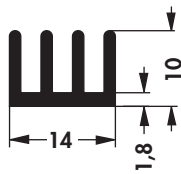
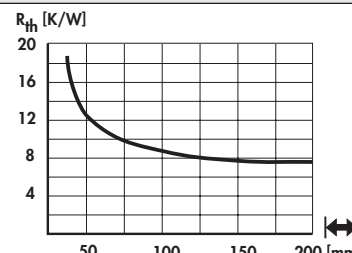
I

art. no.		
		
SK 552 ...		
please indicate:	...  25 37.5 50 75 100 1000 mm	... custom processing (optional) CNC = individual CNC machining WL = desired length

K

L

M

N

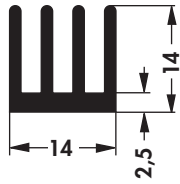
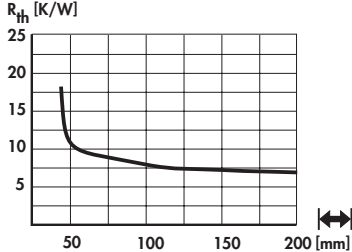
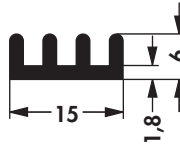
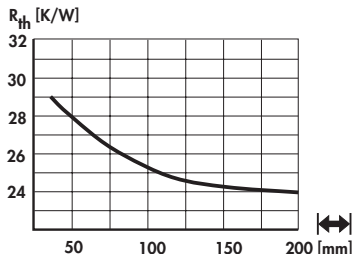
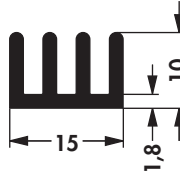
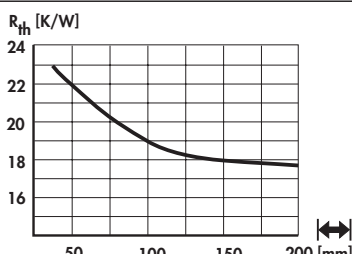
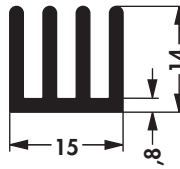
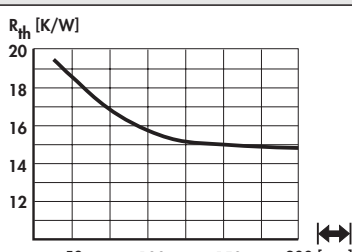
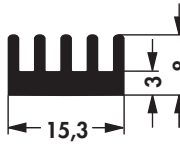
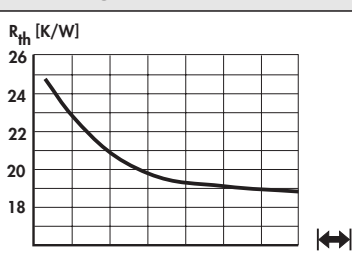

Standard extruded heatsinks

<p>art. no.</p> <p>SK 558 ...</p>		
<p>please indicate: ... $\left[\right]$</p> <p>25 37.5 50 75 100 1000 mm</p>		<p>... custom processing (optional)</p> <p>CNC = individual CNC machining</p> <p>WL = desired length</p>
<p>art. no.</p> <p>SK 688 ...</p>		
<p>please indicate: ... $\left[\right]$</p> <p>25 37.5 50 75 100 1000 mm</p>		<p>... custom processing (optional)</p> <p>CNC = individual CNC machining</p> <p>WL = desired length</p>
<p>art. no.</p> <p>SK 693 ...</p>		
<p>please indicate: ... $\left[\right]$</p> <p>25 37.5 50 75 100 1000 mm</p>		<p>... custom processing (optional)</p> <p>CNC = individual CNC machining</p> <p>WL = desired length</p>
<p>art. no.</p> <p>SK 694 ...</p>		
<p>please indicate: ... $\left[\right]$</p> <p>25 37.5 50 75 100 1000 mm</p>		<p>... custom processing (optional)</p> <p>CNC = individual CNC machining</p> <p>WL = desired length</p>
<p>art. no.</p> <p>SK 521 ...</p>		
<p>please indicate: ... $\left[\right]$</p> <p>25 37.5 50 75 100 1000 mm</p>		<p>... custom processing (optional)</p> <p>CNC = individual CNC machining</p> <p>WL = desired length</p>

B

C

D

E

F

G

H

I

K

L

M

N



Standard extruded heatsinks

B

C

art. no.		
SK 437 ...	extruded heatsinks for PCB mounting → A 149	

please indicate: ... **100 1000 mm**

... custom processing (optional)
CNC = individual CNC machining
WL = desired length

D

E

art. no.		
SK 675 ...		

please indicate: ... **25 37.5 50 75 100 1000 mm**

... custom processing (optional)
CNC = individual CNC machining
WL = desired length

F

G

art. no.		
SK 631 ...		

please indicate: ... **25 37.5 50 75 100 1000 mm**

... custom processing (optional)
CNC = individual CNC machining
WL = desired length

H

I

art. no.		
SK 632 ...		

please indicate: ... **25 37.5 50 75 100 1000 mm**

... custom processing (optional)
CNC = individual CNC machining
WL = desired length

K

L

M

N

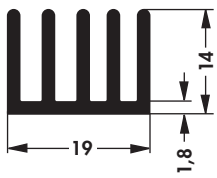
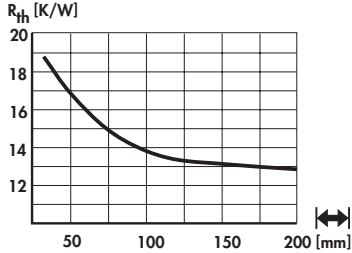
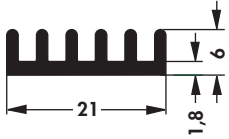
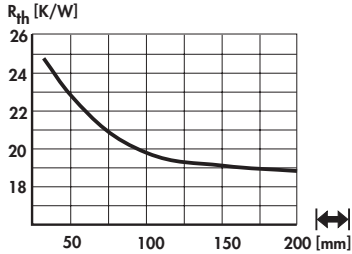
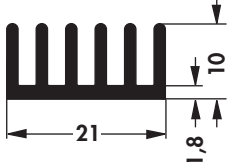
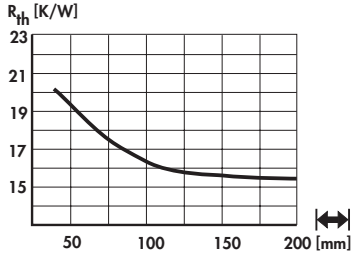
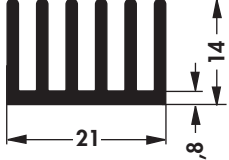
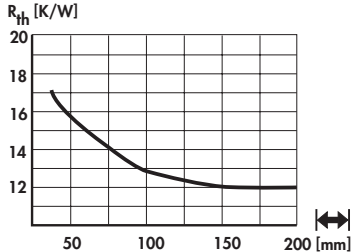

Standard extruded heatsinks

<p>art. no.</p> <p>SK 633 ...</p>		
<p>please indicate: ... $\left[\right]$ 25 37.5 50 75 100 1000 mm</p> <p>... custom processing (optional) CNC = individual CNC machining WL = desired length</p>		
<p>art. no.</p> <p>SK 476 ...</p>		
<p>please indicate: ... $\left[\right]$ 37.5 50 75 100 1000 mm</p> <p>... custom processing (optional) CNC = individual CNC machining WL = desired length</p>		
<p>art. no.</p> <p>SK 652 ...</p>		
<p>please indicate: ... $\left[\right]$ 25 37.5 50 75 100 150 1000 mm</p> <p>... custom processing (optional) CNC = individual CNC machining WL = desired length</p>		
<p>art. no.</p> <p>SK 653 ...</p>		
<p>please indicate: ... $\left[\right]$ 25 37.5 50 75 100 150 1000 mm</p> <p>... custom processing (optional) CNC = individual CNC machining WL = desired length</p>		

B

C

D

E

F

G

H

I

K

L

M



Standard extruded heatsinks

B

C

D

E

F

G

H







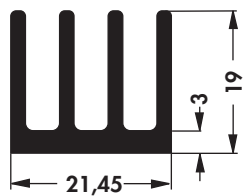
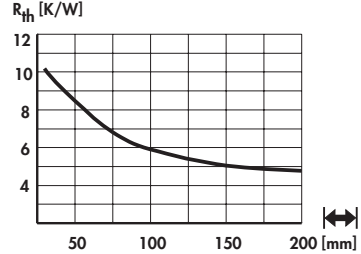

I

K

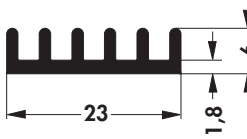
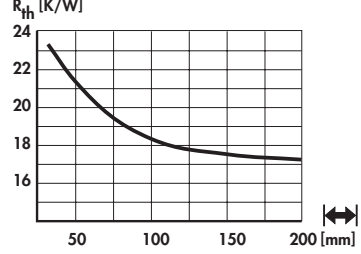
L

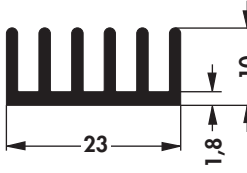
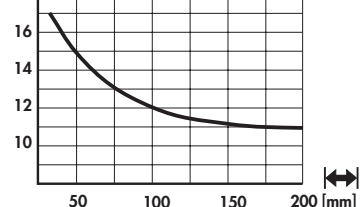
M

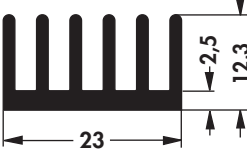
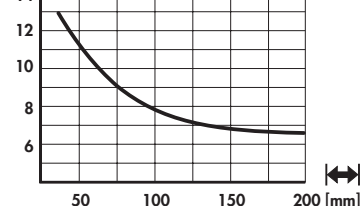
N

art. no. SK 454 ...		
extruded heatsinks for PCB mounting → A 136		
please indicate: ...  25 37.5 50 75 100 150 1000 mm		
... custom processing (optional) CNC = individual CNC machining WL = desired length		
art. no. SK 477 ...		
please indicate: ...  37.5 50 100 1000 mm		
... custom processing (optional) CNC = individual CNC machining WL = desired length		
art. no. SK 582 ...		
please indicate: ...  37.5 50 75 100 1000 mm		
... custom processing (optional) CNC = individual CNC machining WL = desired length		
art. no. SK 559 ...		
please indicate: ...  37.5 75 100 1000 mm		
... custom processing (optional) CNC = individual CNC machining WL = desired length		



Standard extruded heatsinks

<p>art. no.</p> <p>SK 551 ...</p>		
<p>please indicate: ... \longleftrightarrow</p> <p>37.5 50 75 100 1000 mm</p>		<p>... custom processing (optional)</p> <p>CNC = individual CNC machining</p> <p>WL = desired length</p>
<p>art. no.</p> <p>SK 486 ...</p>		
<p>please indicate: ... \longleftrightarrow</p> <p>37.5 50 75 100 1000 mm</p>		<p>... custom processing (optional)</p> <p>CNC = individual CNC machining</p> <p>WL = desired length</p>
<p>art. no.</p> <p>SK 473 ...</p>		
<p>please indicate: ... \longleftrightarrow</p> <p>37.5 50 75 1000 mm</p>		<p>... custom processing (optional)</p> <p>CNC = individual CNC machining</p> <p>WL = desired length</p>
<p>art. no.</p> <p>SK 554 ...</p>		
<p>please indicate: ... \longleftrightarrow</p> <p>37.5 50 75 100 1000 mm</p>		<p>... custom processing (optional)</p> <p>CNC = individual CNC machining</p> <p>WL = desired length</p>
<p>art. no.</p> <p>SK 447 ...</p>		
<p>please indicate: ... \longleftrightarrow</p> <p>37.5 1000 mm</p>		<p>... custom processing (optional)</p> <p>CNC = individual CNC machining</p> <p>WL = desired length</p>

B

C

D

E

F

G

H

I

K

L



M



Standard extruded heatsinks

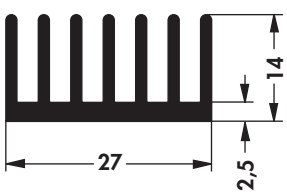
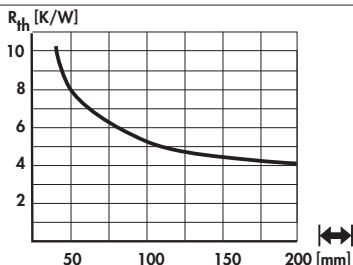

B

C

art. no.		
SK 560 ...		
please indicate:	...  37.5 50 75 100 1000 mm	... custom processing (optional) CNC = individual CNC machining WL = desired length

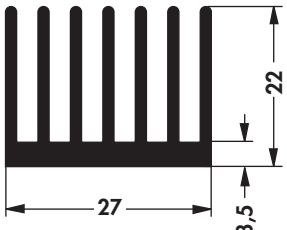
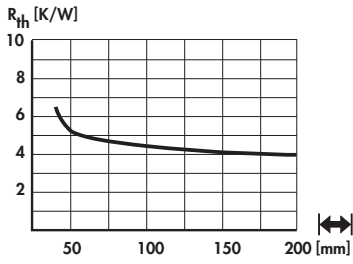

D

E

art. no.		
SK 566 ...		
please indicate:	...  37.5 50 75 100 1000 mm	... custom processing (optional) CNC = individual CNC machining WL = desired length

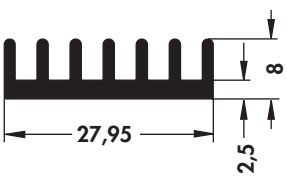
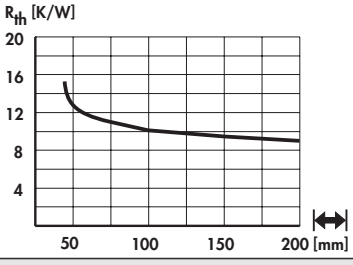

F

G

art. no.		
SK 561 ...		
please indicate:	...  37.5 50 75 100 1000 mm	... custom processing (optional) CNC = individual CNC machining WL = desired length

H

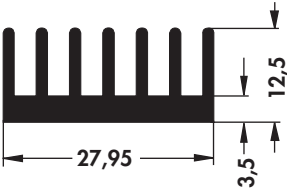
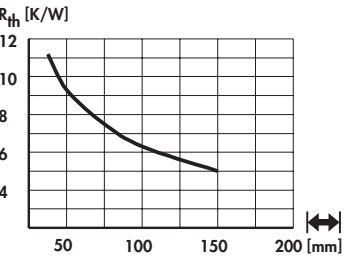
I

art. no.		
SK 448 ...		
please indicate:	...  37.5 50 75 mm	... custom processing (optional) CNC = individual CNC machining WL = desired length

extruded heatsinks for PCB mounting → A 151

K

L

M

N

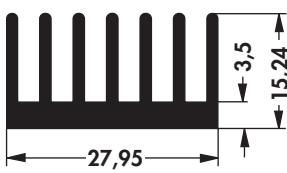
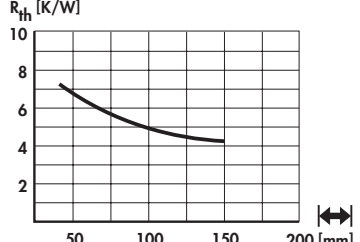
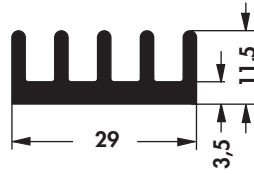
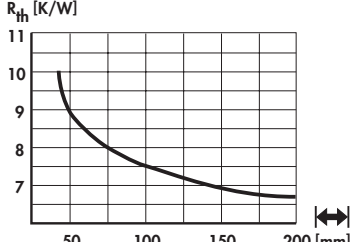
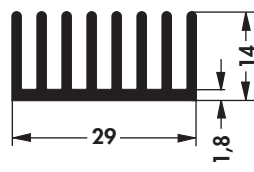
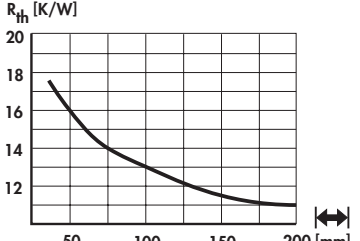
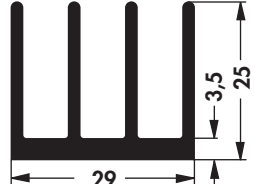
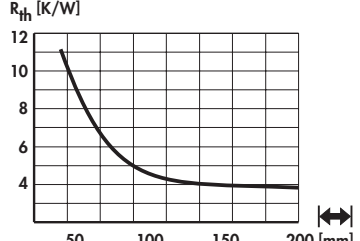

Standard extruded heatsinks

<p>art. no.</p> <p>SK 177 ...</p>		
<p>please indicate: ... $\left\langle \right\rangle$</p> <p>50 75 100 1000 mm</p>		<p>... custom processing (optional)</p> <p>CNC = individual CNC machining</p> <p>WL = desired length</p>
<p>art. no.</p> <p>SK 550 ...</p>		
<p>please indicate: ... $\left\langle \right\rangle$</p> <p>37.5 50 75 100 1000 mm</p>		<p>... custom processing (optional)</p> <p>CNC = individual CNC machining</p> <p>WL = desired length</p>
<p>art. no.</p> <p>SK 691 ...</p>		
<p>please indicate: ... $\left\langle \right\rangle$</p> <p>37.5 50 75 100 1000 mm</p>		<p>... custom processing (optional)</p> <p>CNC = individual CNC machining</p> <p>WL = desired length</p>
<p>art. no.</p> <p>SK 452 ...</p>		
<p>extruded heatsinks for PCB mounting → A 136</p>		
<p>please indicate: ... $\left\langle \right\rangle$</p> <p>37.5 100 1000 mm</p>		<p>... custom processing (optional)</p> <p>CNC = individual CNC machining</p> <p>WL = desired length</p>



B
C
D
E
F
G
H
I
K
L
M
N



Standard extruded heatsinks

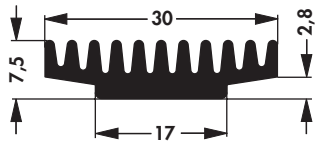
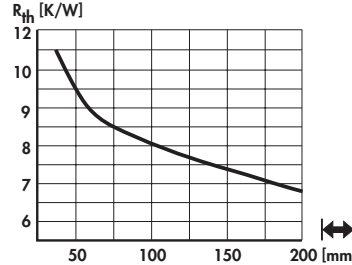

B

C

art. no.		
SK 677 ...		
please indicate:	...  37.5 50 75 100 1000 mm	... custom processing (optional) CNC = individual CNC machining WL = desired length

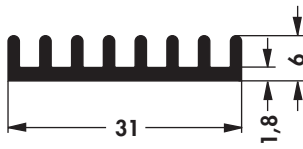
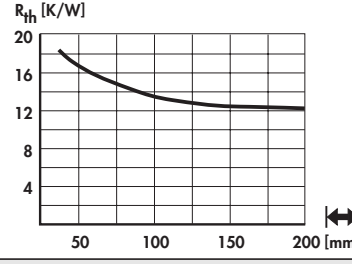

D

E

art. no.		
SK 493 ...		
please indicate:	...  37.5 50 75 100 1000 mm	... custom processing (optional) CNC = individual CNC machining WL = desired length

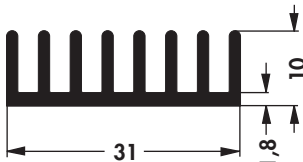
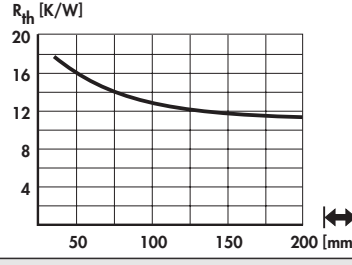

F

G

art. no.		
SK 581 ...		
please indicate:	...  37.5 50 75 100 1000 mm	... custom processing (optional) CNC = individual CNC machining WL = desired length

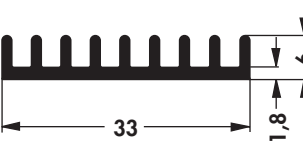
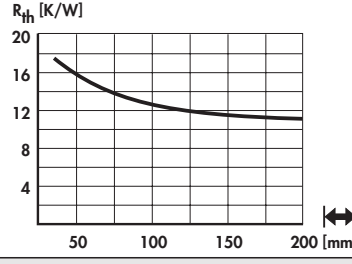

H

I

art. no.		
SK 634 ...		
please indicate:	...  37.5 50 75 100 1000 mm	... custom processing (optional) CNC = individual CNC machining WL = desired length

K

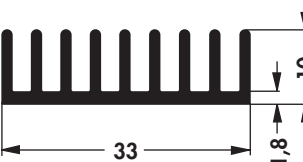
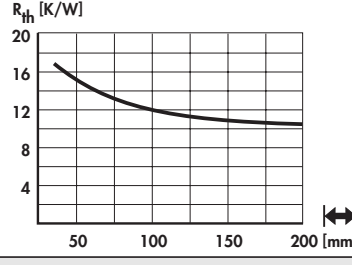
L

art. no.		
SK 635 ...		
please indicate:	...  37.5 50 75 100 1000 mm	... custom processing (optional) CNC = individual CNC machining WL = desired length

M

N

Standard extruded heatsinks

<p>art. no.</p>		
<p>SK 400 ... extruded heatsinks for PCB mounting → A 151</p>		
<p>please indicate: ... \longleftrightarrow 37.5 50 75 100 1000 mm</p> <p>... custom processing (optional) CNC = individual CNC machining WL = desired length</p>		
<p>art. no.</p>		
<p>SK 636 ...</p> <p>please indicate: ... \longleftrightarrow 37.5 50 75 100 1000 mm</p> <p>... custom processing (optional) CNC = individual CNC machining WL = desired length</p>		
<p>art. no.</p>		
<p>SK 460 ... extruded heatsinks for PCB mounting → A 152</p>		
<p>please indicate: ... \longleftrightarrow 25 37.5 50 1000 mm</p> <p>... custom processing (optional) CNC = individual CNC machining WL = desired length</p>		
<p>art. no.</p>		
<p>SK 126 ... extruded heatsinks for PCB mounting → A 147</p>		
<p>please indicate: ... \longleftrightarrow 25 37.5 1000 mm</p> <p>... custom processing (optional) CNC = individual CNC machining WL = desired length</p>		

B

C

D

E

F

G

H

I

K

L

M

N



Standard extruded heatsinks

B

C

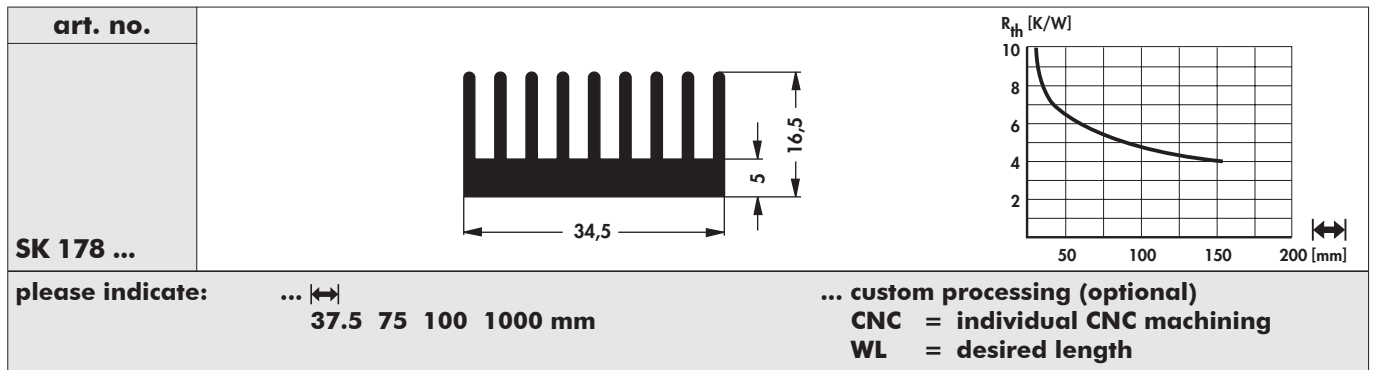

D

E

F

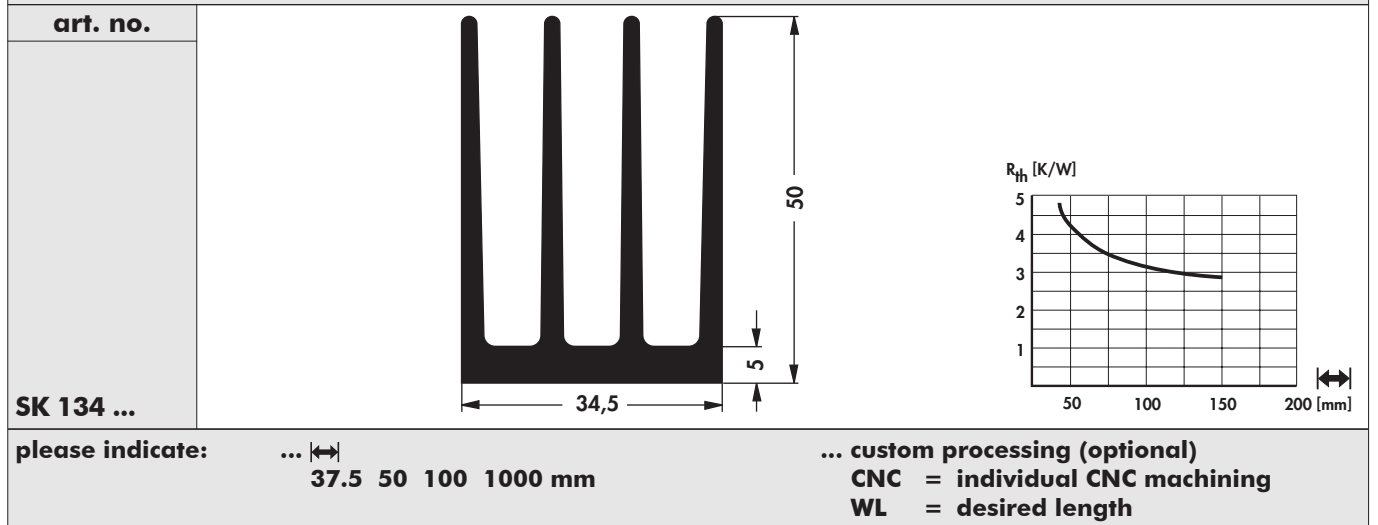

G

H

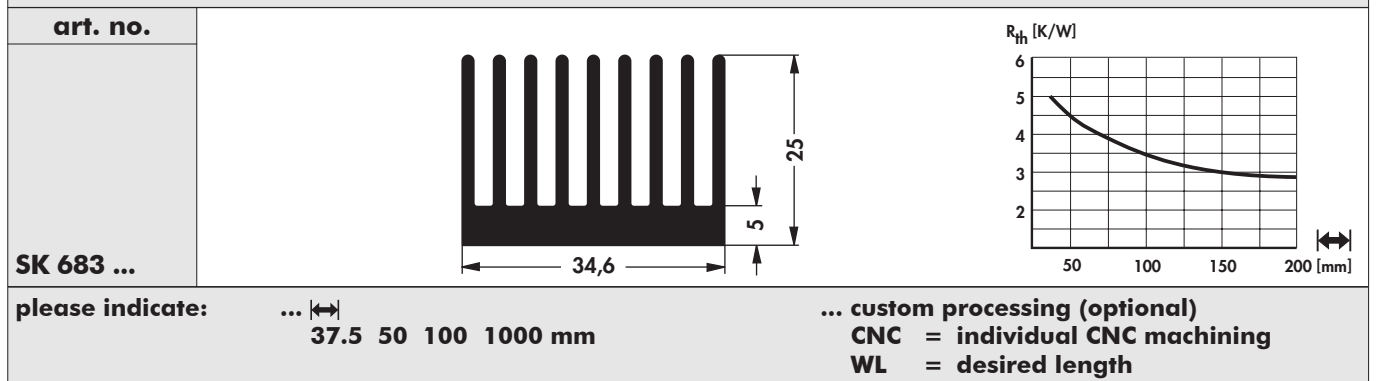

I

K

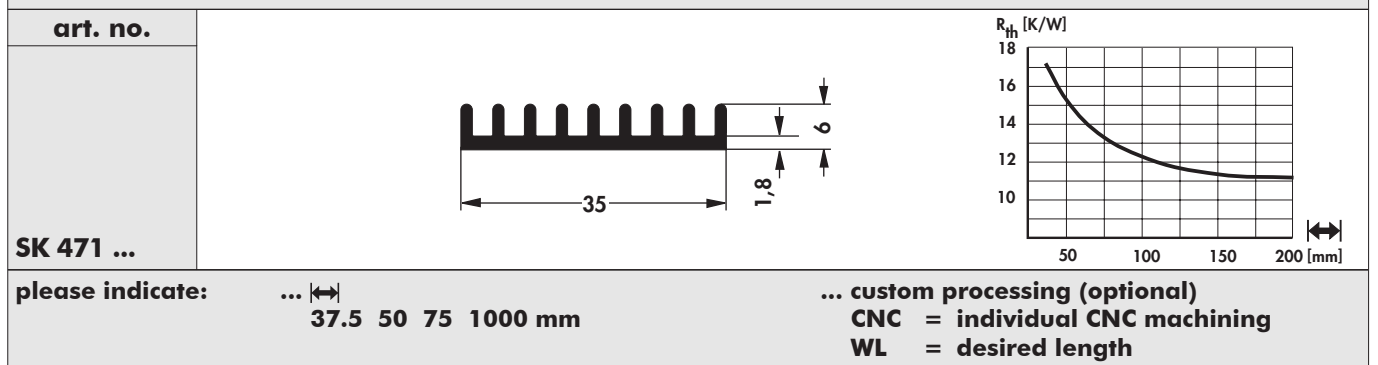

L

M

N



Standard extruded heatsinks

<p>art. no.</p> <p>SK 587 ...</p>		
<p>please indicate: ... $\left[\right]$ 37.5 50 75 100 1000 mm</p> <p>... custom processing (optional) CNC = individual CNC machining WL = desired length</p>		
<p>art. no.</p> <p>SK 549 ...</p>		
<p>please indicate: ... $\left[\right]$ 37.5 50 75 100 1000 mm</p> <p>... custom processing (optional) CNC = individual CNC machining WL = desired length</p>		
<p>art. no.</p> <p>SK 562 ...</p>		
<p>please indicate: ... $\left[\right]$ 37.5 50 75 100 1000 mm</p> <p>... custom processing (optional) CNC = individual CNC machining WL = desired length</p>		
<p>art. no.</p> <p>SK 654 ...</p>		
<p>please indicate: ... $\left[\right]$ 37.5 50 100 150 1000 mm</p> <p>... custom processing (optional) CNC = individual CNC machining WL = desired length</p>		

B

C

D

E

F

G

H

I

K

L

M

N



Standard extruded heatsinks

B

C

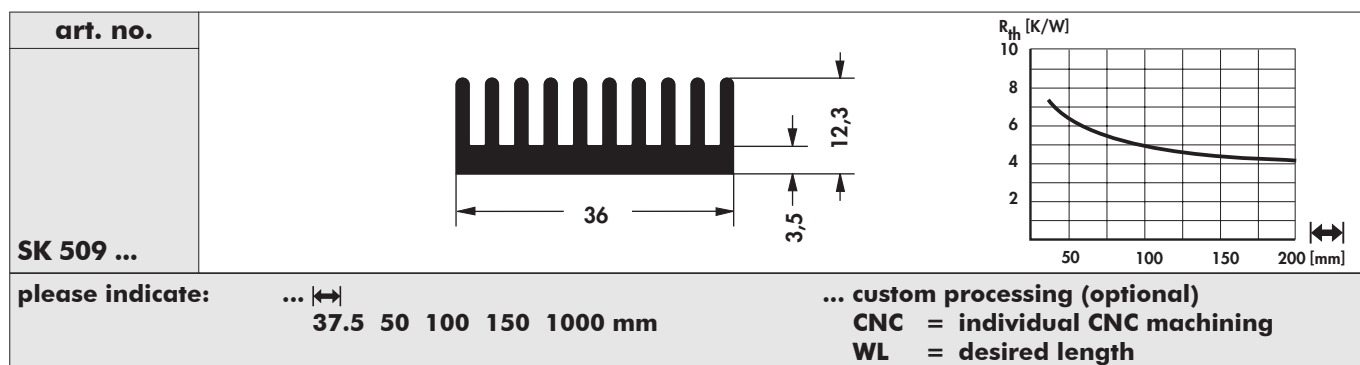

D

E

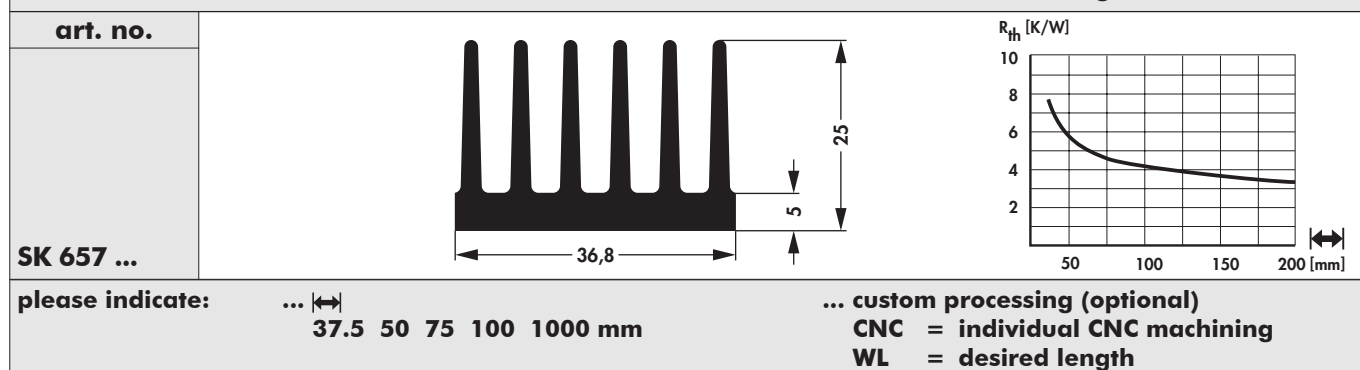

F

G

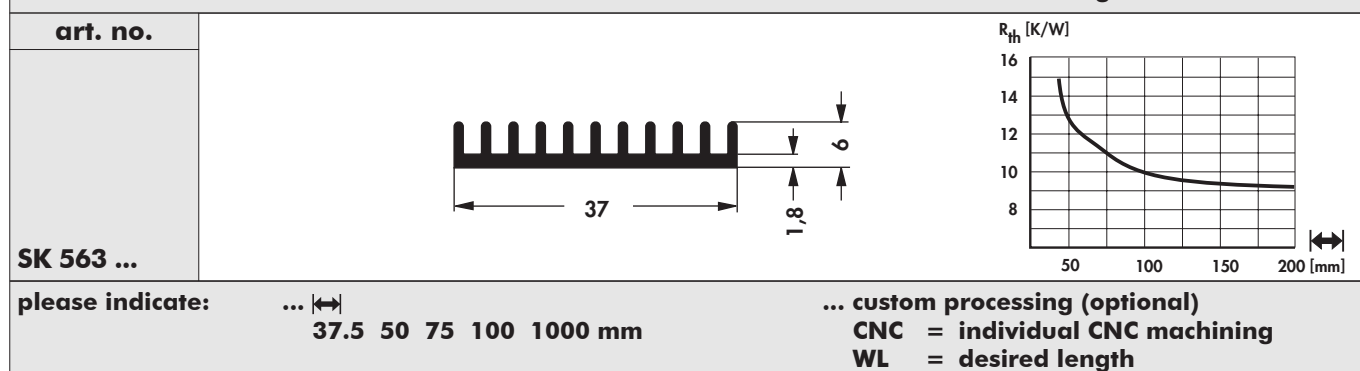

H

I

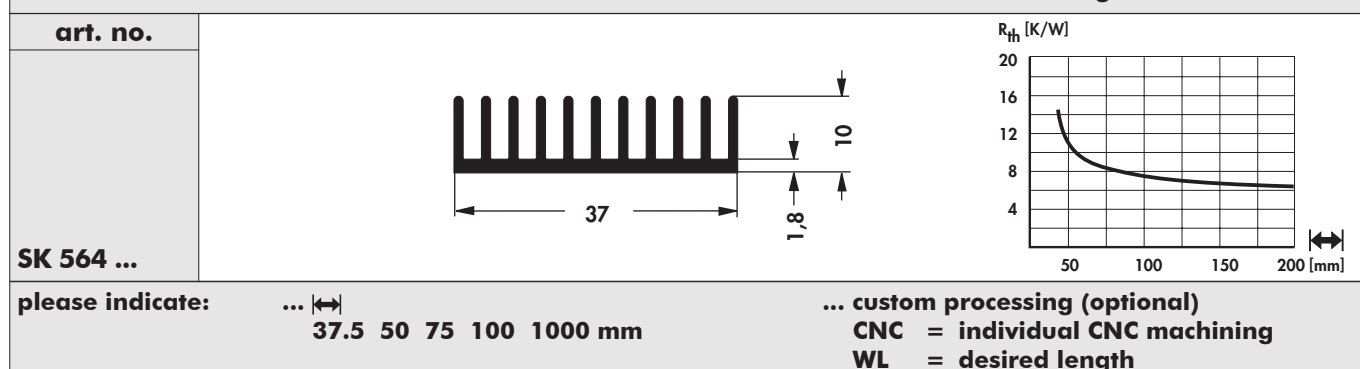

K

L

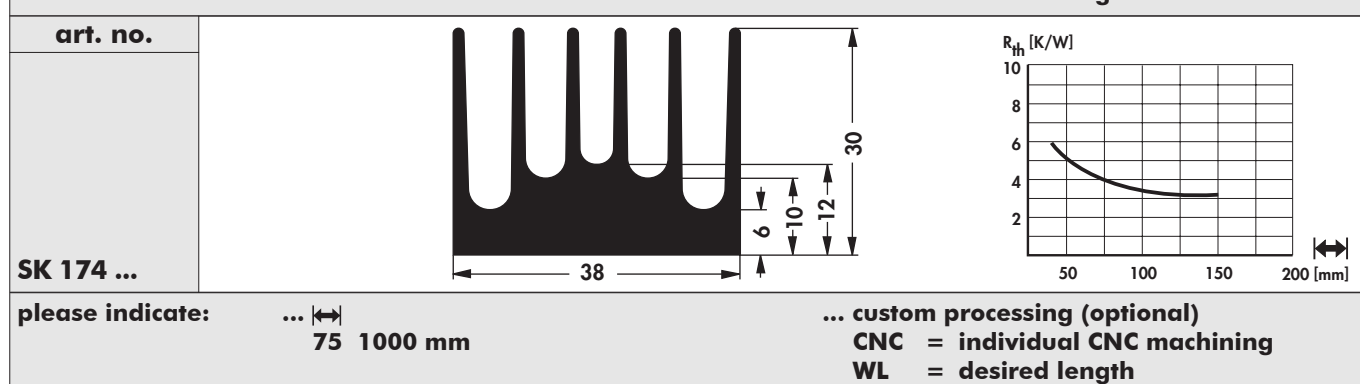

M

N

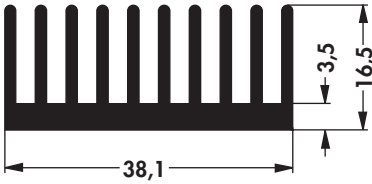
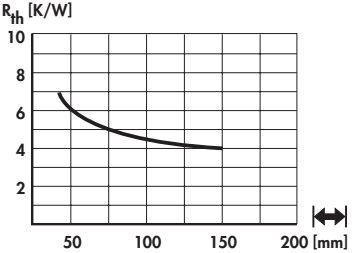
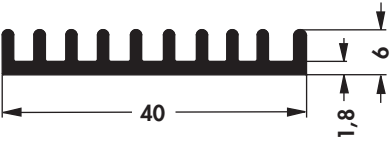
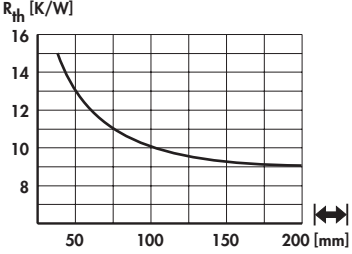
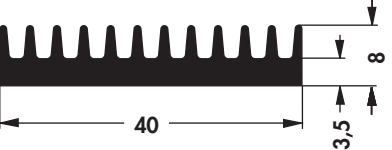
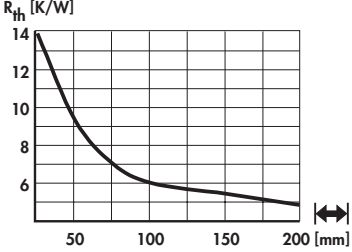
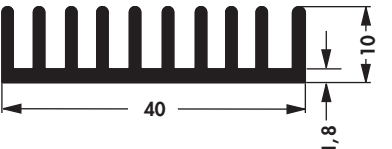
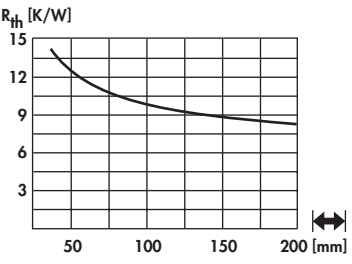

Standard extruded heatsinks

<p>art. no.</p> <p>SK 179 ...</p>		
<p>please indicate: ... $\left[\right]$ 37.5 50 100 1000 mm</p> <p>... custom processing (optional) CNC = individual CNC machining WL = desired length</p>		
<p>art. no.</p> <p>SK 456 ...</p>	 <p>extruded heatsinks for PCB mounting → A 151</p>	
<p>please indicate: ... $\left[\right]$ 37.5 50 75 100 1000 mm</p> <p>... custom processing (optional) CNC = individual CNC machining WL = desired length</p>		
<p>art. no.</p> <p>SK 420 ...</p>		
<p>please indicate: ... $\left[\right]$ 37.5 75 1000 mm</p> <p>... custom processing (optional) CNC = individual CNC machining WL = desired length</p>		
<p>art. no.</p> <p>SK 513 ...</p>		
<p>please indicate: ... $\left[\right]$ 37.5 50 75 100 1000 mm</p> <p>... custom processing (optional) CNC = individual CNC machining WL = desired length</p>		

B
C
D
E
F
G
H
I
K
L
M
N



Standard extruded heatsinks

B

C

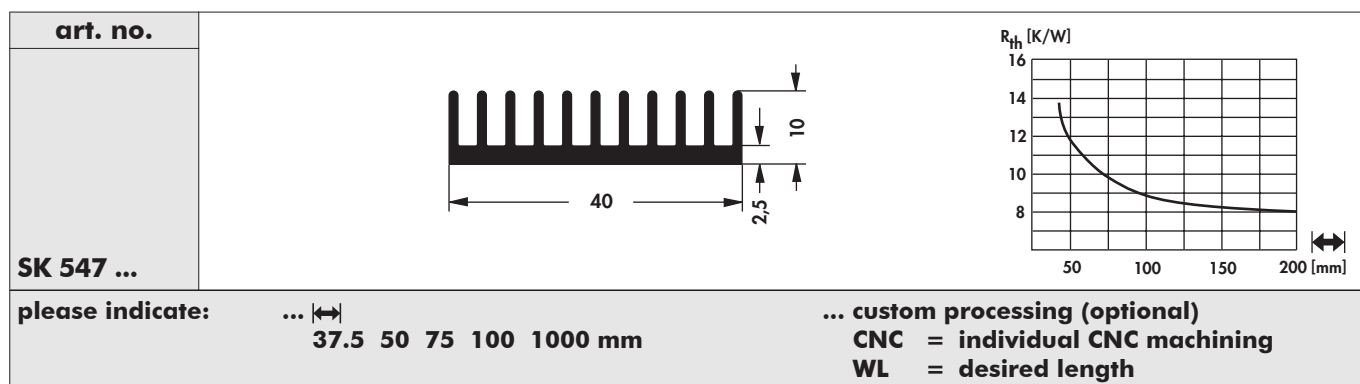

D

E

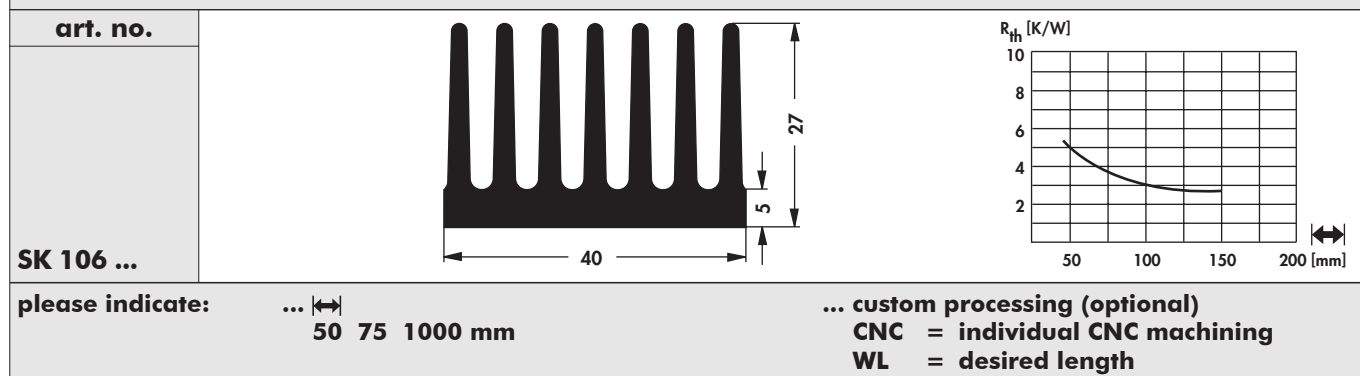

F

G

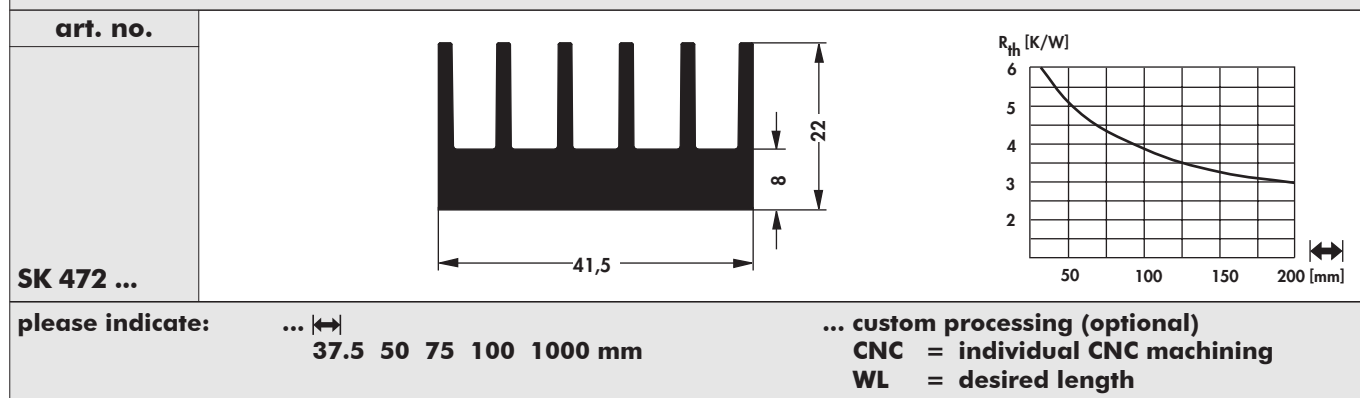

H

I

K

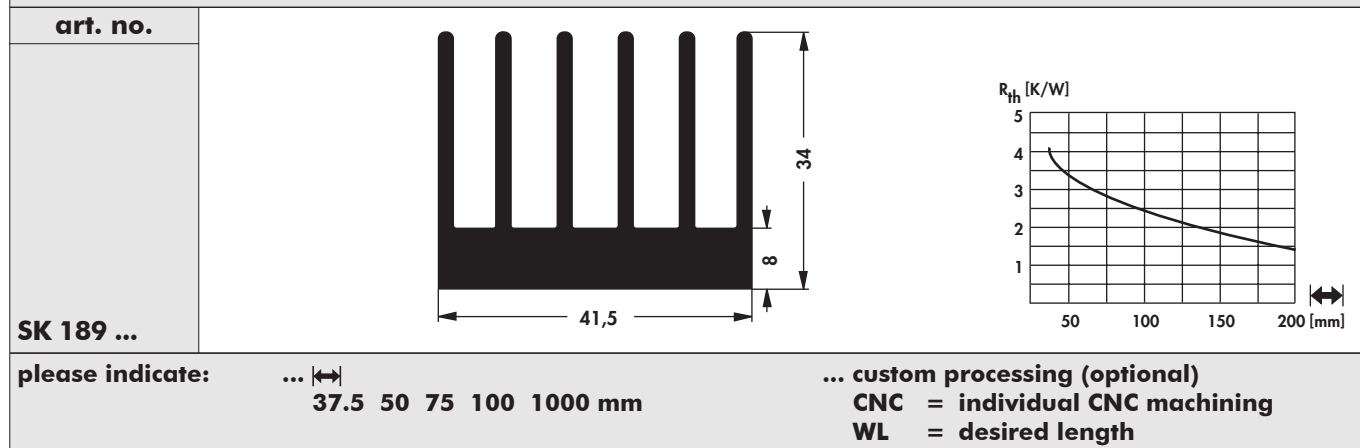

L

M

N



Standard extruded heatsinks



<p>art. no.</p> <p>SK 679 ...</p>		
<p>please indicate: ... \longleftrightarrow 37.5 50 75 100 1000 mm</p> <p>... custom processing (optional) CNC = individual CNC machining WL = desired length</p>		
<p>art. no.</p> <p>SK 423 ...</p>		
<p>please indicate: ... \longleftrightarrow 100 1000 mm</p> <p>... custom processing (optional) CNC = individual CNC machining WL = desired length</p>		
<p>art. no.</p> <p>SK 422 ...</p>		
<p>please indicate: ... \longleftrightarrow 50 1000 mm</p> <p>... custom processing (optional) CNC = individual CNC machining WL = desired length</p>		
<p>art. no.</p> <p>SK 511 ...</p>		
<p>please indicate: ... \longleftrightarrow 50 75 100 1000 mm</p> <p>... custom processing (optional) CNC = individual CNC machining WL = desired length</p>		



Standard extruded heatsinks

B

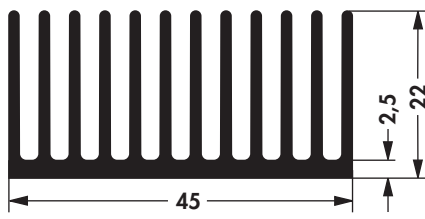
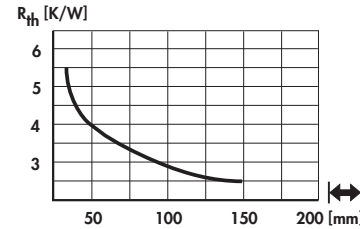

C

art. no.		
SK 626 ...		
please indicate: ...  50 75 100 1000 mm		
... custom processing (optional) CNC = individual CNC machining WL = desired length		

D

E

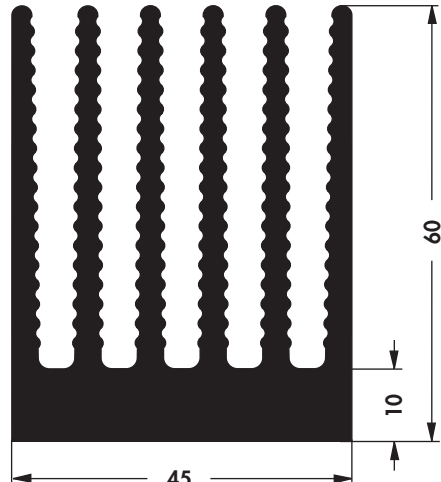
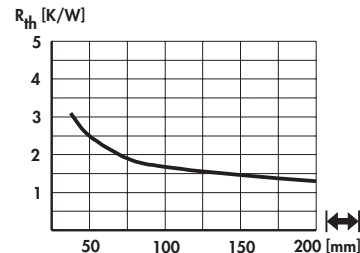
F



art. no.		
SK 453 ...		
please indicate: ...  37.5 75 mm		
... ϕ (optional) SSR 1		
... custom processing (optional) CNC = individual CNC machining WL = desired length		

G

H

I

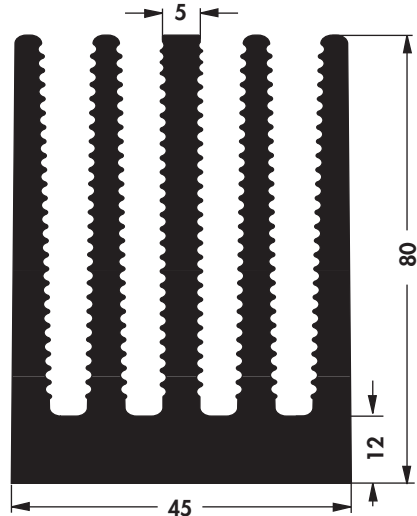
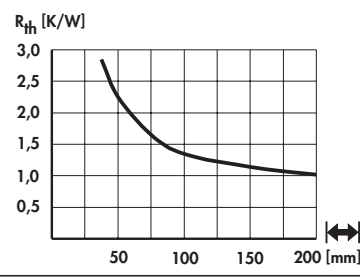
K







art. no.		
SK 455 ...		
please indicate: ...  75 mm		
... ϕ (optional) SSR 1; SSR 4		
... custom processing (optional) CNC = individual CNC machining WL = desired length		

L

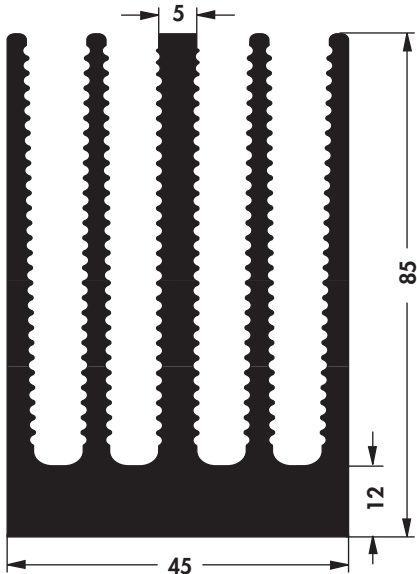
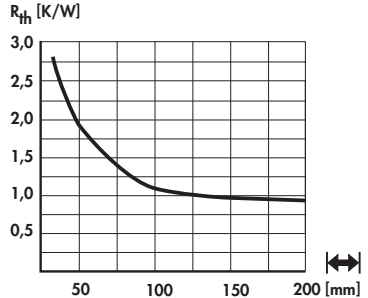
M

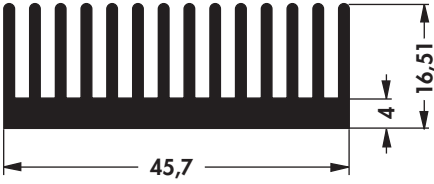
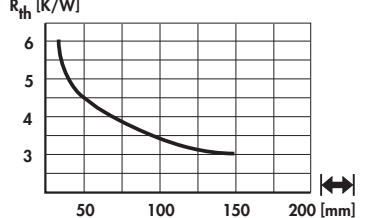
N

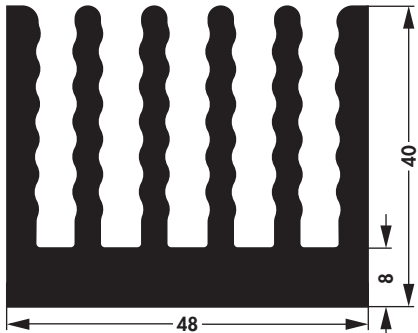
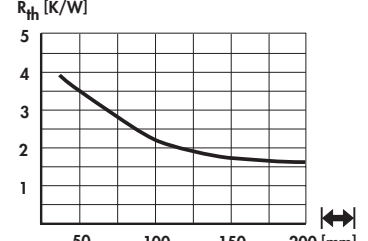
Standard extruded heatsinks

<p>art. no.</p> <p>SK 467 ...</p>		
<p>please indicate: ...  37.5 50 75 100 1000 mm ...  (optional) SSR 1; SSR 4</p> <p>... custom processing (optional) CNC = individual CNC machining WL = desired length</p>		
<p>art. no.</p> <p>SK 424 ...</p>		
<p>please indicate: ...  75 1000 mm ... custom processing (optional) CNC = individual CNC machining WL = desired length</p>		
<p>art. no.</p> <p>SK 666 ...</p>		
<p>please indicate: ...  37.5 50 75 100 150 1000 mm ... custom processing (optional) CNC = individual CNC machining WL = desired length</p>		

B

C

D

E

F

G

H

I

K

L

M

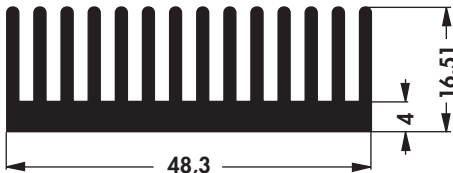
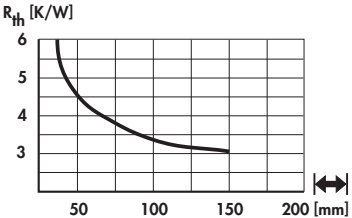
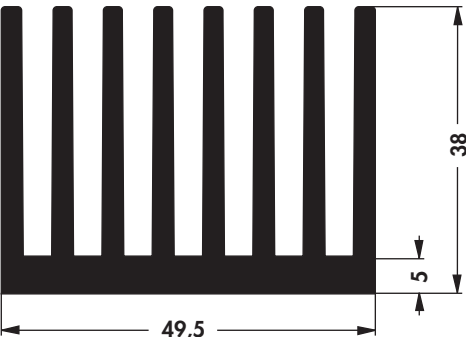
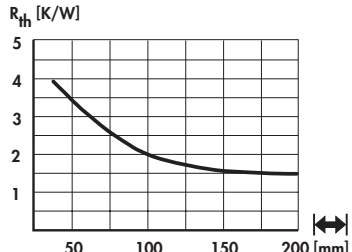
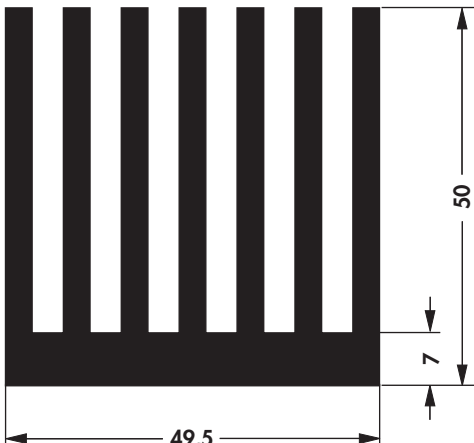
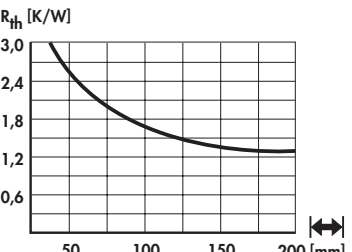
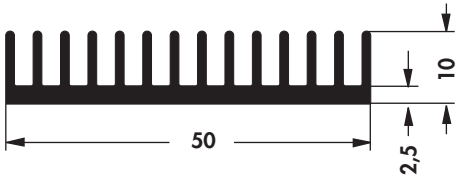
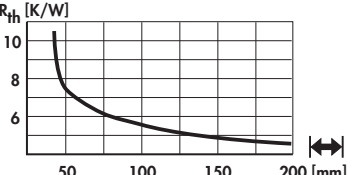

Standard extruded heatsinks

art. no. SK 425 ...		
<p>please indicate: ... $\left[\begin{array}{c} \text{---} \\ \text{---} \end{array} \right]$ 75 mm</p> <p>... custom processing (optional) CNC = individual CNC machining WL = desired length</p>		
art. no. SK 445 ...		
<p>please indicate: ... $\left[\begin{array}{c} \text{---} \\ \text{---} \end{array} \right]$ 100 1000 mm</p> <p>... custom processing (optional) CNC = individual CNC machining WL = desired length</p>		
art. no. SK 450 ...		
<p>please indicate: ... $\left[\begin{array}{c} \text{---} \\ \text{---} \end{array} \right]$ 75 1000 mm</p> <p>... custom processing (optional) CNC = individual CNC machining WL = desired length</p>		
art. no. SK 548 ...		
<p>please indicate: ... $\left[\begin{array}{c} \text{---} \\ \text{---} \end{array} \right]$ 37.5 50 75 100 1000 mm</p> <p>... custom processing (optional) CNC = individual CNC machining WL = desired length</p>		



Standard extruded heatsinks

<p>art. no.</p> <p>SK 567 ...</p>		
<p>please indicate: ... $\left[\right]$ 37.5 50 75 100 1000 mm</p> <p>... custom processing (optional) CNC = individual CNC machining WL = desired length</p>		
<p>art. no.</p> <p>SK 434 ...</p>		
<p>please indicate: ... $\left[\right]$ 50 75 100 1000 mm</p> <p>... \diamond (optional) SSR 1</p> <p>... custom processing (optional) CNC = individual CNC machining WL = desired length</p>		
<p>art. no.</p> <p>SK 475 ...</p>		
<p>please indicate: ... $\left[\right]$ 37.5 50 100 1000 mm</p> <p>... custom processing (optional) CNC = individual CNC machining WL = desired length</p>		

B

C

D

E

F

G

H

I

K

L

M

N



Standard extruded heatsinks

B

C

D

E

F

G

H

I

K

L

M

art. no. SK 527 ...		
<p>please indicate: ... $\left[\begin{array}{c} \text{---} \\ \text{---} \\ \text{---} \end{array} \right]$ 50 75 100 1000 mm</p> <p>... custom processing (optional) CNC = individual CNC machining WL = desired length</p>		
art. no. SK 427 ...		
<p>please indicate: ... $\left[\begin{array}{c} \text{---} \\ \text{---} \\ \text{---} \end{array} \right]$ 50 75 1000 mm</p> <p>... custom processing (optional) CNC = individual CNC machining WL = desired length</p>		
art. no. SK 426 ...		
<p>please indicate: ... $\left[\begin{array}{c} \text{---} \\ \text{---} \\ \text{---} \end{array} \right]$ 37.5 50 75 100 1000 mm</p> <p>... custom processing (optional) CNC = individual CNC machining WL = desired length</p>		
art. no. SK 156 ...		
<p>please indicate: ... $\left[\begin{array}{c} \text{---} \\ \text{---} \\ \text{---} \end{array} \right]$ 37.5 50 75 100 1000 mm</p> <p>... custom processing (optional) CNC = individual CNC machining WL = desired length</p>		



Standard extruded heatsinks

<p>art. no.</p> <p>SK 468 ...</p>		
<p>please indicate: ... $\left[\begin{array}{c} \text{---} \\ \text{---} \end{array} \right]$ 37.5 75 1000 mm</p> <p>... custom processing (optional) CNC = individual CNC machining WL = desired length</p>		
<p>art. no.</p> <p>SK 667 ...</p>		
<p>please indicate: ... $\left[\begin{array}{c} \text{---} \\ \text{---} \end{array} \right]$ 37.5 50 75 100 150 1000 mm</p> <p>... custom processing (optional) CNC = individual CNC machining WL = desired length</p>		
<p>art. no.</p> <p>SK 180 ...</p>		
<p>please indicate: ... $\left[\begin{array}{c} \text{---} \\ \text{---} \end{array} \right]$ 37.5 50 75 100 1000 mm</p> <p>... custom processing (optional) CNC = individual CNC machining WL = desired length</p>		
<p>art. no.</p> <p>SK 99 ...</p>		
<p>please indicate: ... $\left[\begin{array}{c} \text{---} \\ \text{---} \end{array} \right]$ 37.5 50 75 100 150 1000 mm</p> <p>... custom processing (optional) CNC = individual CNC machining WL = desired length</p>		

- B
- C
- D
- E
- F
- G
- H
- I
- K
- L
- M
- N



Standard extruded heatsinks

B

C

D

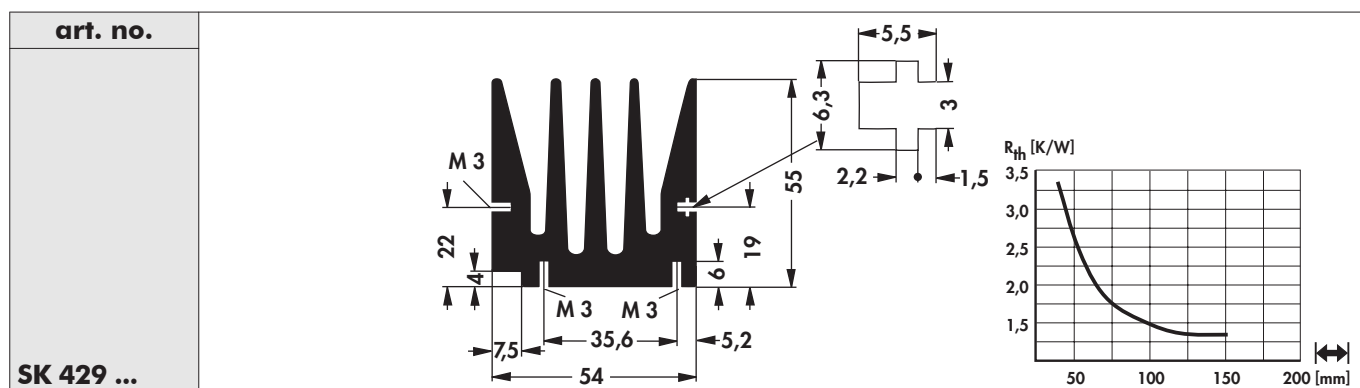

please indicate: ... **37.5 50 75 100 1000 mm**

... **custom processing (optional)**
CNC = individual CNC machining
WL = desired length

E

F

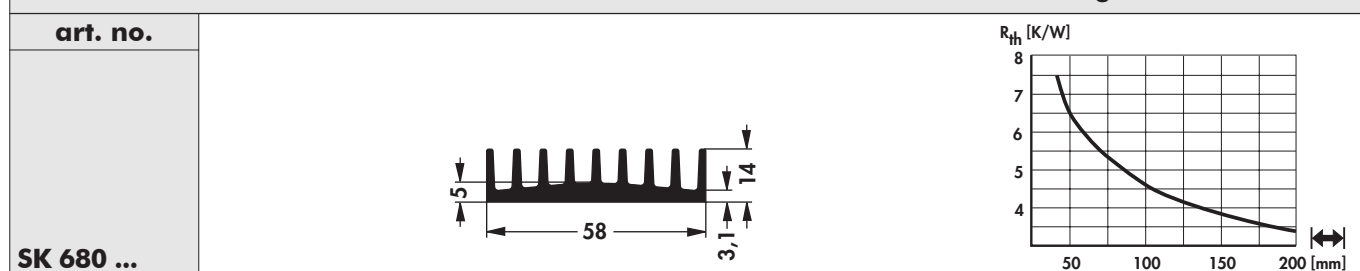

please indicate: ... **37.5 50 75 100 1000 mm**

... **custom processing (optional)**
CNC = individual CNC machining
WL = desired length

G

H

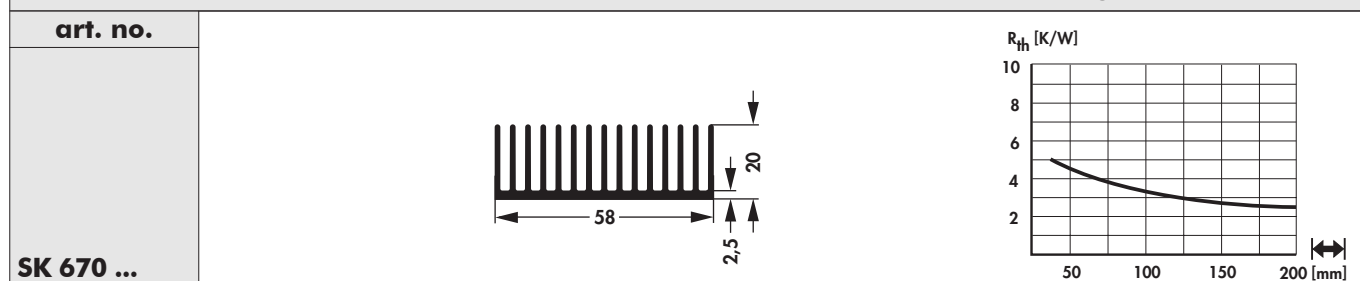

please indicate: ... **37.5 50 75 100 1000 mm**

... **custom processing (optional)**
CNC = individual CNC machining
WL = desired length

I

K

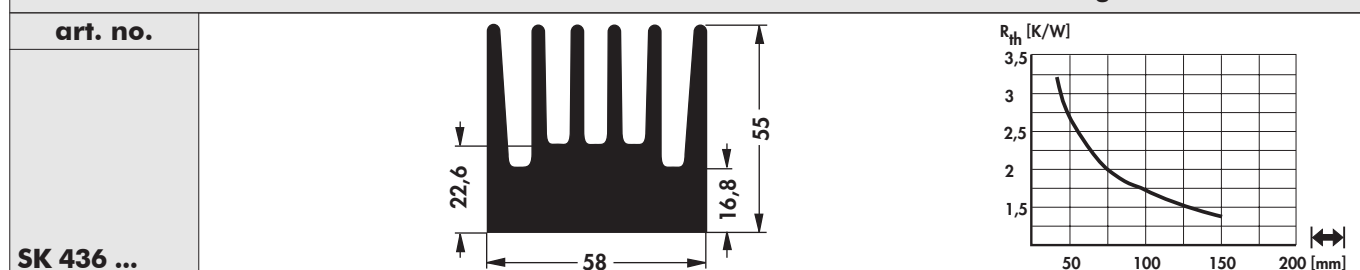

please indicate: ... **75 1000 mm**

... **custom processing (optional)**
CNC = individual CNC machining
WL = desired length

L

M

N



Standard extruded heatsinks

<p>art. no.</p> <p>SK 50 ...</p>		
<p>please indicate: ... \longleftrightarrow</p> <p>75 1000 mm</p>		<p>... custom processing (optional)</p> <p>CNC = individual CNC machining</p> <p>WL = desired length</p>
<p>art. no.</p> <p>SK 630 ...</p>		
<p>please indicate: ... \longleftrightarrow</p> <p>37.5 50 75 100 150 1000 mm</p>		<p>... custom processing (optional)</p> <p>CNC = individual CNC machining</p> <p>WL = desired length</p>
<p>art. no.</p> <p>SK 485 ...</p>		
<p>please indicate: ... \longleftrightarrow</p> <p>50 75 100 1000 mm</p>		<p>... custom processing (optional)</p> <p>CNC = individual CNC machining</p> <p>WL = desired length</p>
<p>art. no.</p> <p>SK 647 ...</p>		
<p>please indicate: ... \longleftrightarrow</p> <p>37.5 50 75 100 150 1000 mm</p>		<p>... custom processing (optional)</p> <p>CNC = individual CNC machining</p> <p>WL = desired length</p>

B

C

D

E

F

G

H

I

K

L

M



Standard extruded heatsinks

B

C

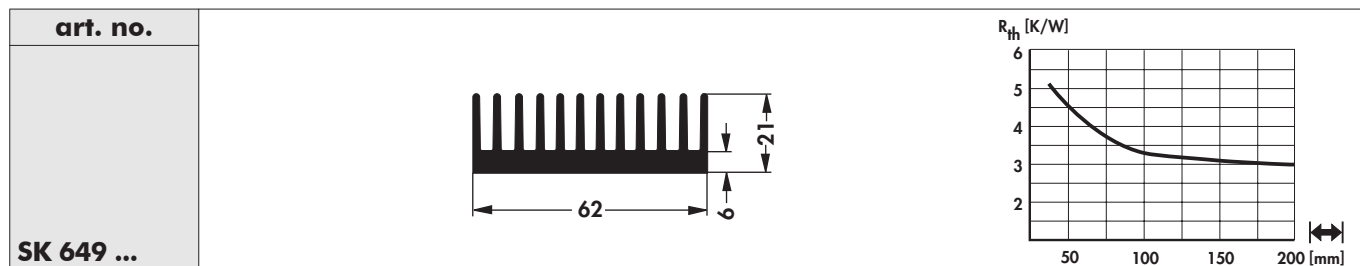

please indicate: ...  37.5 50 75 100 150 1000 mm

... custom processing (optional)
CNC = individual CNC machining
WL = desired length

D

E

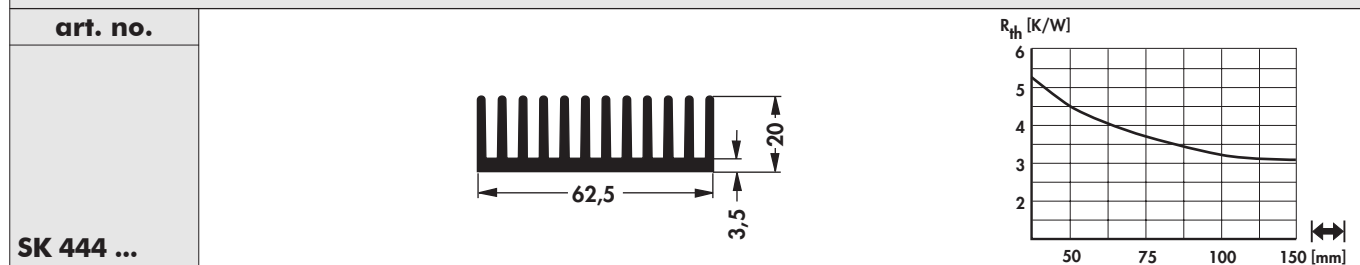



please indicate: ...  37.5 50 75 1000 mm

... custom processing (optional)
CNC = individual CNC machining
WL = desired length

F

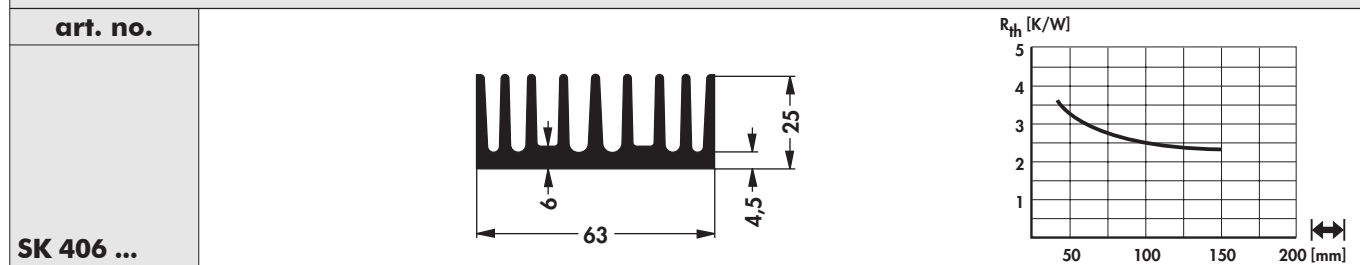
G





please indicate: ...  37.5 50 75 100 1000 mm

... custom processing (optional)
CNC = individual CNC machining
WL = desired length

H

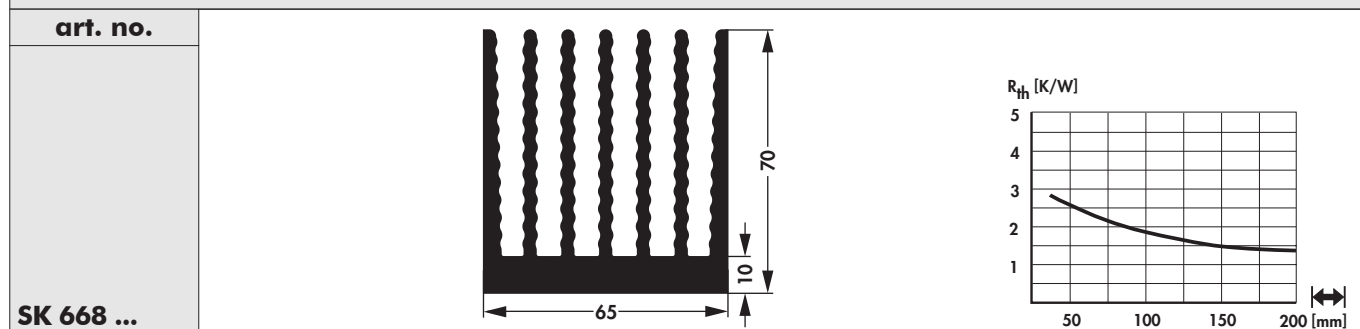
I



please indicate: ...  37.5 50 75 100 150 1000 mm









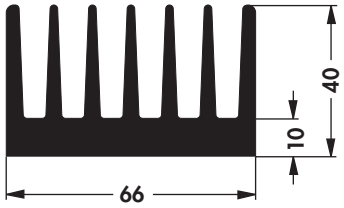
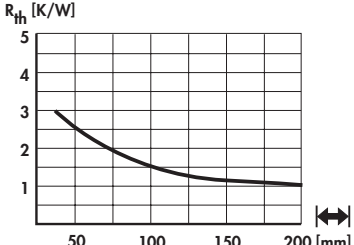

... custom processing (optional)
CNC = individual CNC machining
WL = desired length

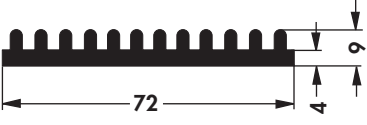
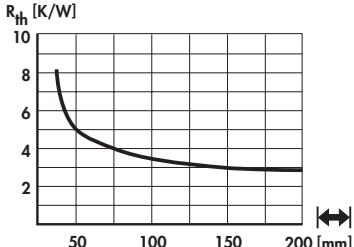
L

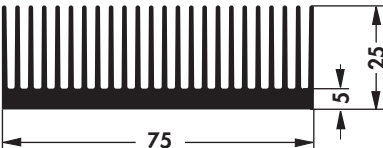
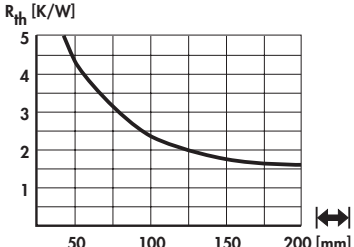
M

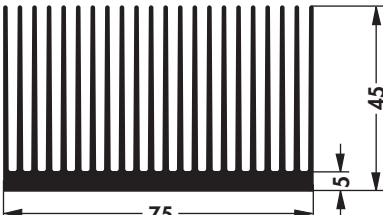
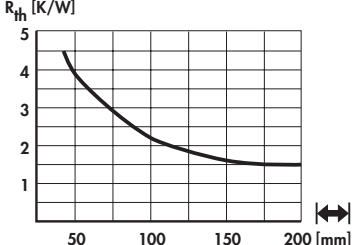
N

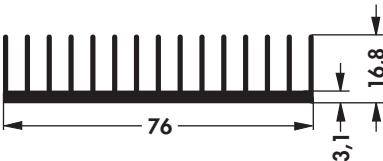
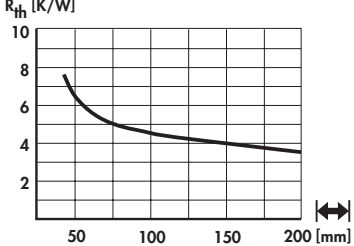
Standard extruded heatsinks

<p>art. no.</p> <p>SK 100 ...</p>		
<p>please indicate: ...  37.5 50 75 100 150 1000 mm</p> <p>... custom processing (optional) CNC = individual CNC machining WL = desired length</p>		
<p>art. no.</p> <p>SK 648 ...</p>		
<p>please indicate: ...  37.5 50 75 100 150 1000 mm</p> <p>... custom processing (optional) CNC = individual CNC machining WL = desired length</p>		
<p>art. no.</p> <p>SK 594 ...</p>		
<p>please indicate: ...  37.5 50 75 100 1000 mm</p> <p>... custom processing (optional) CNC = individual CNC machining WL = desired length</p>		
<p>art. no.</p> <p>SK 628 ...</p>		
<p>please indicate: ...  37.5 50 75 100 150 1000 mm</p> <p>... custom processing (optional) CNC = individual CNC machining WL = desired length</p>		
<p>art. no.</p> <p>SK 686 ...</p>		
<p>please indicate: ...  37.5 50 75 100 150 1000 mm</p> <p>... custom processing (optional) CNC = individual CNC machining WL = desired length</p>		

B

C

D

E

F

G

H

I

K

L

M

N

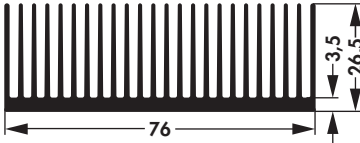
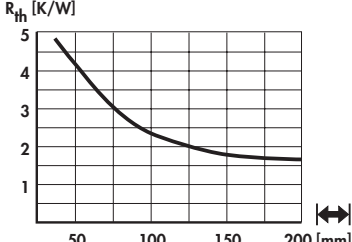
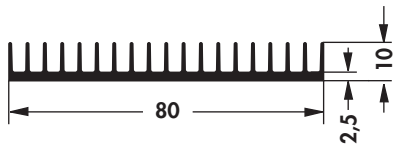
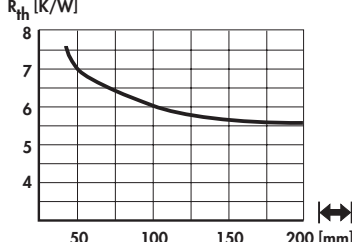
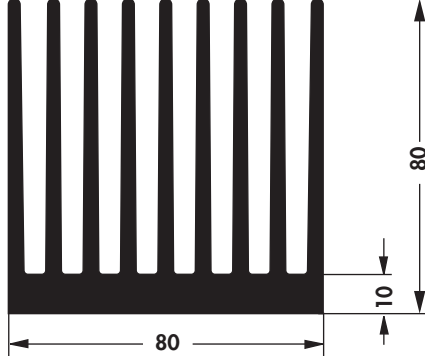
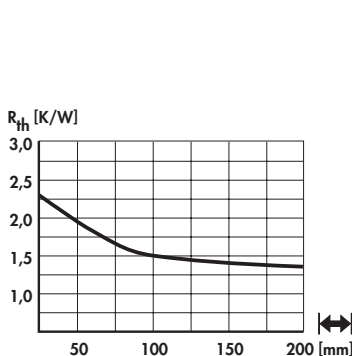
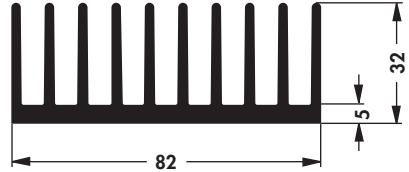
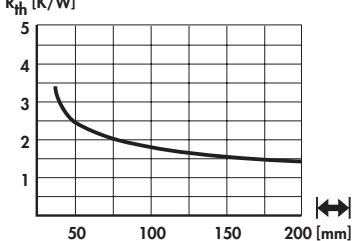

Standard extruded heatsinks

art. no. SK 663 ...		
<p>please indicate: ... $\left[\begin{array}{c} \text{---} \\ \text{---} \end{array} \right]$ 50 75 100 150 1000 mm</p> <p>... custom processing (optional) CNC = individual CNC machining WL = desired length</p>		
art. no. SK 545 ...		
<p>please indicate: ... $\left[\begin{array}{c} \text{---} \\ \text{---} \end{array} \right]$ 50 75 100 150 1000 mm</p> <p>... custom processing (optional) CNC = individual CNC machining WL = desired length</p>		
art. no. SK 655 ...		
<p>please indicate: ... $\left[\begin{array}{c} \text{---} \\ \text{---} \end{array} \right]$ 37.5 50 75 100 150 1000 mm</p> <p>... custom processing (optional) CNC = individual CNC machining WL = desired length</p>		
art. no. SK 612 ...		
<p>please indicate: ... $\left[\begin{array}{c} \text{---} \\ \text{---} \end{array} \right]$ 37.5 50 75 100 150 1000 mm</p> <p>... custom processing (optional) CNC = individual CNC machining WL = desired length</p>		

Standard extruded heatsinks

<p>art. no.</p> <p>SK 135 ...</p>		
<p>please indicate: ... $\left[\begin{array}{c} \text{---} \\ \text{---} \\ \text{---} \end{array} \right]$ 50 100 1000 mm</p> <p>... custom processing (optional) CNC = individual CNC machining WL = desired length</p>		
<p>art. no.</p> <p>SK 407 ...</p>		
<p>please indicate: ... $\left[\begin{array}{c} \text{---} \\ \text{---} \\ \text{---} \end{array} \right]$ 37.5 50 75 100 1000 mm</p> <p>... custom processing (optional) CNC = individual CNC machining WL = desired length</p>		
<p>art. no.</p> <p>SK 464 ...</p>		
<p>please indicate: ... $\left[\begin{array}{c} \text{---} \\ \text{---} \\ \text{---} \end{array} \right]$ 50 75 100 150 1000 mm</p> <p>... custom processing (optional) CNC = individual CNC machining WL = desired length</p>		
<p>art. no.</p> <p>SK 182 ...</p>		
<p>please indicate: ... $\left[\begin{array}{c} \text{---} \\ \text{---} \\ \text{---} \end{array} \right]$ 37.5 50 75 100 150 200 1000 mm</p> <p>... custom processing (optional) CNC = individual CNC machining WL = desired length</p>		

B

C

D

E

F

G

H

I

K

L

M

N



Standard extruded heatsinks

B

C

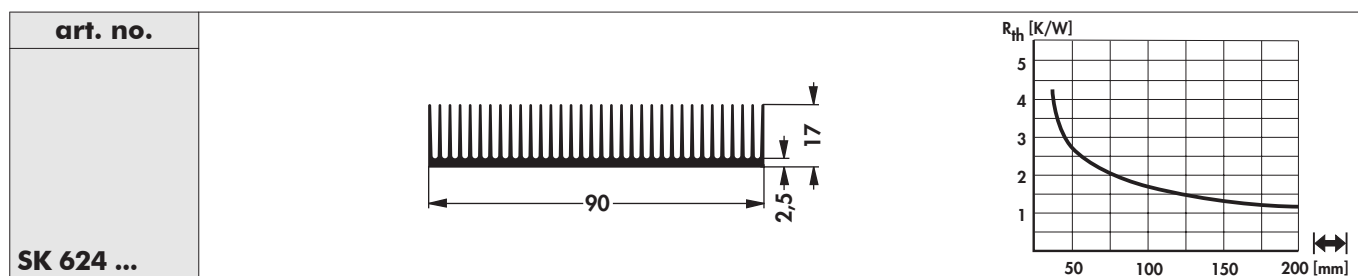

SK 624 ...

please indicate:

...  37.5 50 75 100 150 200 1000 mm

... custom processing (optional)
CNC = individual CNC machining
WL = desired length

D

E

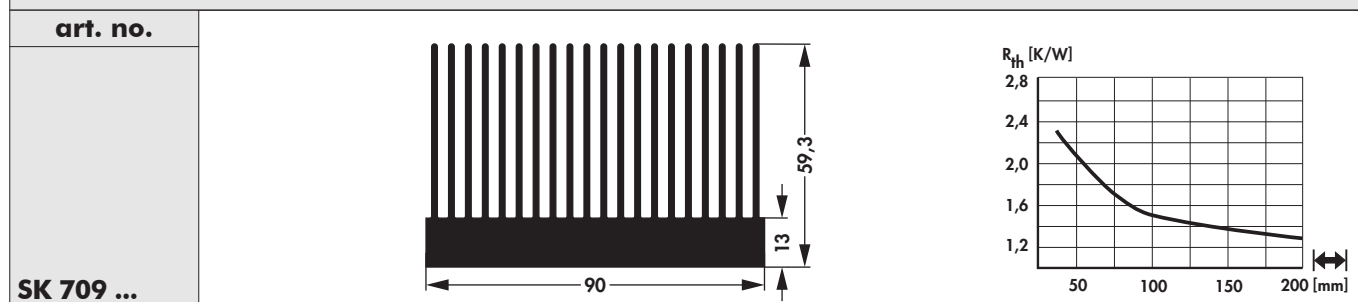

SK 709 ...

please indicate:

...  37.5 50 75 100 150 200 1000 mm

... custom processing (optional)
CNC = individual CNC machining
WL = desired length

F

G

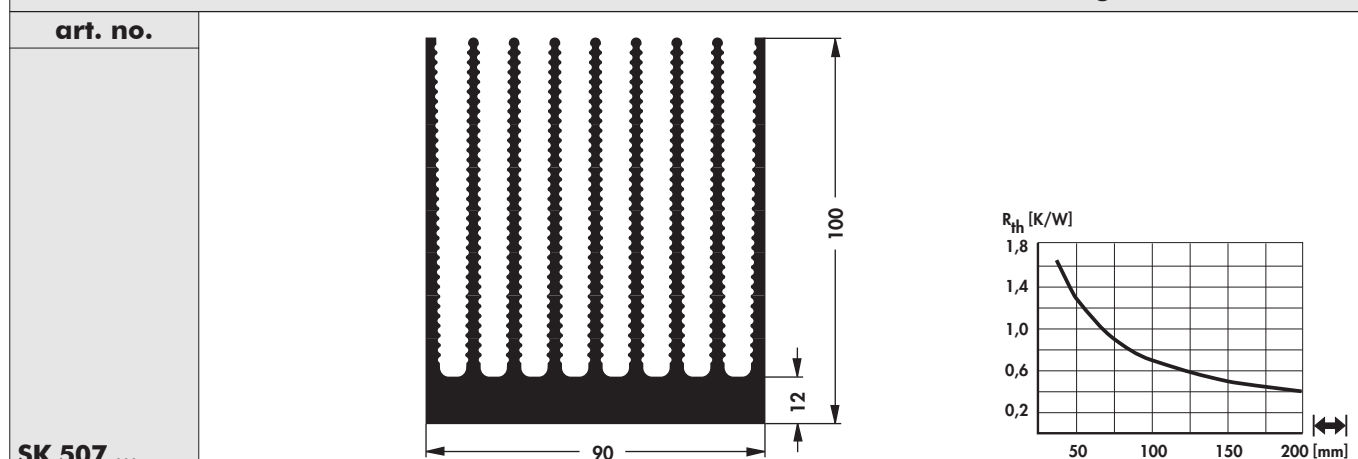

SK 507 ...

please indicate:

...  37.5 75 100 1000 mm

... ϕ (optional)
SSR 1; SSR 2

... custom processing (optional)
CNC = individual CNC machining
WL = desired length

I

K

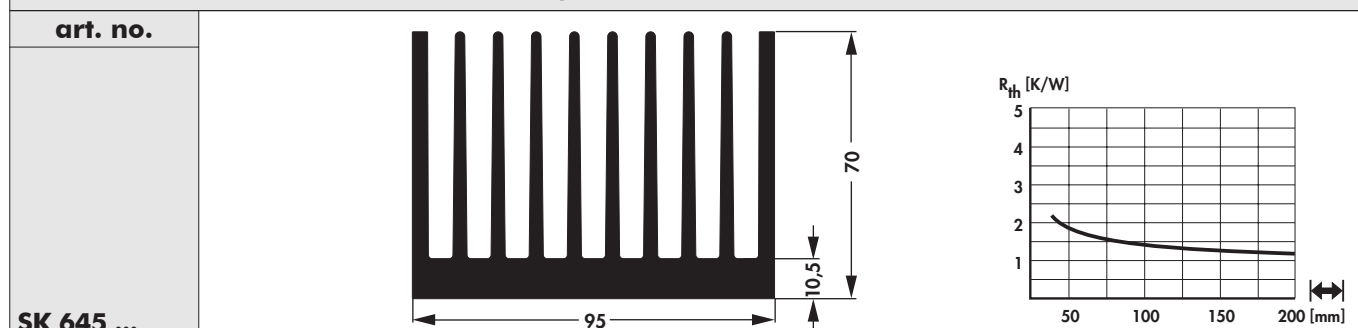

SK 645 ...

please indicate:

...  37.5 50 75 100 150 1000 mm

... custom processing (optional)
CNC = individual CNC machining
WL = desired length

M

N



Standard extruded heatsinks

<p>art. no.</p> <p>SK 408 ...</p>		
<p>please indicate: ... \longleftrightarrow 50 75 100 150 1000 mm</p> <p>... custom processing (optional) CNC = individual CNC machining WL = desired length</p>		
<p>art. no.</p> <p>SK 546 ...</p>		
<p>please indicate: ... \longleftrightarrow 37.5 50 75 100 150 1000 mm</p> <p>... custom processing (optional) CNC = individual CNC machining WL = desired length</p>		
<p>art. no.</p> <p>SK 81 ...</p>		
<p>please indicate: ... \longleftrightarrow 37.5 50 75 100 1000 mm</p> <p>... custom processing (optional) CNC = individual CNC machining WL = desired length</p>		
<p>art. no.</p> <p>SK 505 ...</p> <p>weight reduced like SK 81</p>		
<p>please indicate: ... \longleftrightarrow 37.5 50 75 100 150 1000 mm</p> <p>... custom processing (optional) CNC = individual CNC machining WL = desired length</p>		

B

C

D

E

F

G

H

I

K

L

M

N



Standard extruded heatsinks

B

C

art. no.		
SK 508 ...		
<p>please indicate: ... 37.5 50 75 100 1000 mm</p> <p style="text-align: right;">... custom processing (optional) CNC = individual CNC machining WL = desired length</p>		

D

E

art. no.		
SK 706 ...		
<p>please indicate: ... 50 75 100 150 1000 mm</p> <p style="text-align: right;">... custom processing (optional) CNC = individual CNC machining WL = desired length</p>		

F

G

art. no.		
SK 92 ...		
<p>please indicate: ... 50 75 100 150 1000 mm</p> <p style="text-align: right;">... custom processing (optional) CNC = individual CNC machining WL = desired length</p>		

H

I







art. no.		
SK 644 ...		
<p>please indicate: ... 37.5 50 75 100 150 1000 mm</p> <p style="text-align: right;">... custom processing (optional) CNC = individual CNC machining WL = desired length</p>		

K

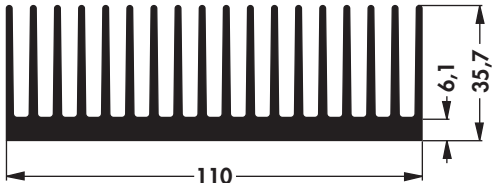
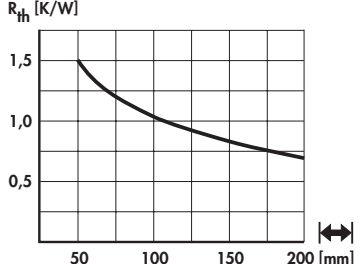
L

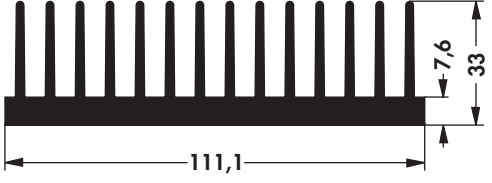
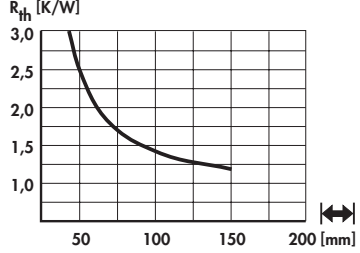
M

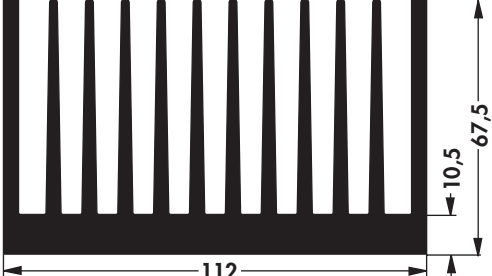
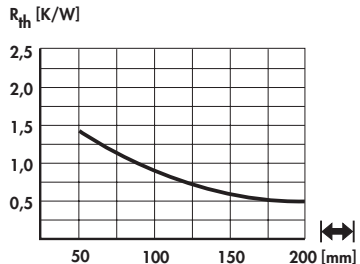
Standard extruded heatsinks

<p>art. no.</p> <p>SK 684 ...</p>		
<p>please indicate: ...  50 75 100 150 1000 mm</p> <p>... custom processing (optional) CNC = individual CNC machining WL = desired length</p>		
<p>art. no.</p> <p>SK 433 ...</p>		
<p>please indicate: ...  37.5 50 75 1000 mm</p> <p>... custom processing (optional) CNC = individual CNC machining WL = desired length</p>		
<p>art. no.</p> <p>SK 121 ...</p>		
<p>please indicate: ...  75 100 150 1000 mm</p> <p>... custom processing (optional) CNC = individual CNC machining WL = desired length</p>		

B
C
D
E
F
G
H
I
K
L
M
N

Standard extruded heatsinks

B

C

D

E

F

G

H

I

K

L

M

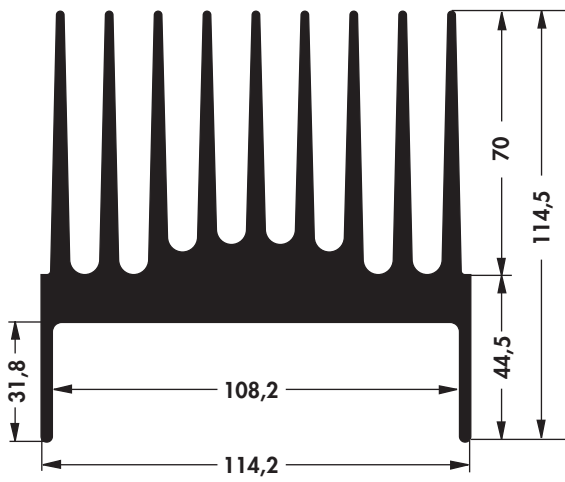
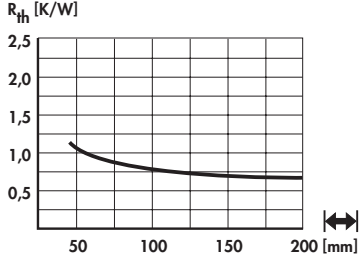
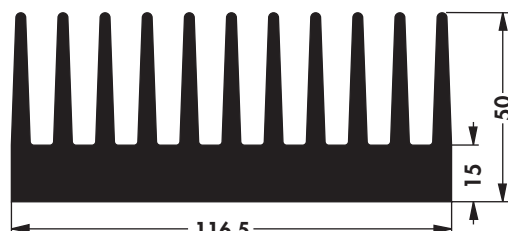
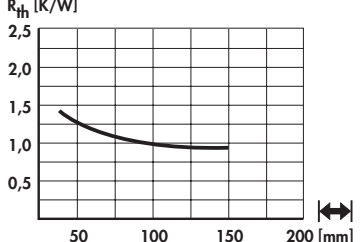
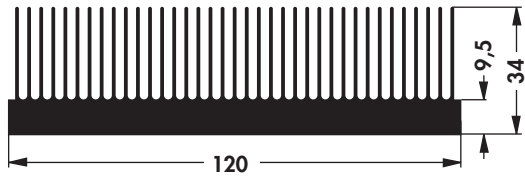
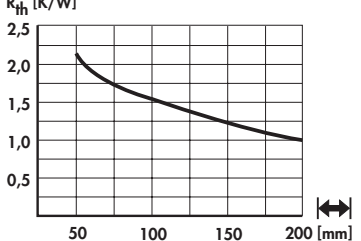
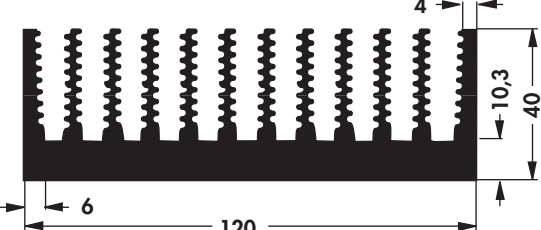
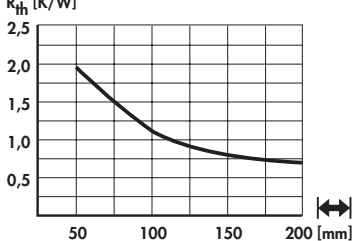
art. no. SK 33 ...		
<p>please indicate: ... $\left[\begin{array}{c} \\ \hline \end{array} \right]$ 50 75 100 1000 mm ... \diamond (optional) SSR 1</p> <p>... custom processing (optional) CNC = individual CNC machining WL = desired length</p>		
art. no. SK 411 ...		
<p>please indicate: ... $\left[\begin{array}{c} \\ \hline \end{array} \right]$ 50 75 100 150 1000 mm ... custom processing (optional) CNC = individual CNC machining WL = desired length</p>		
art. no. SK 625 ...		
<p>please indicate: ... $\left[\begin{array}{c} \\ \hline \end{array} \right]$ 50 75 100 150 1000 mm ... custom processing (optional) CNC = individual CNC machining WL = desired length</p>		
art. no. SK 442 ...		
<p>please indicate: ... $\left[\begin{array}{c} \\ \hline \end{array} \right]$ 50 75 100 150 1000 mm ... custom processing (optional) CNC = individual CNC machining WL = desired length</p>		



Standard extruded heatsinks

<p>art. no.</p> <p>SK 595 ...</p>		
<p>please indicate: ... $\left[\right]$ 50 75 100 150 1000 mm</p> <p>... custom processing (optional) CNC = individual CNC machining WL = desired length</p>		
<p>art. no.</p> <p>SK 463 ...</p>		
<p>please indicate: ... $\left[\right]$ 50 75 100 150 1000 mm</p> <p>... custom processing (optional) CNC = individual CNC machining WL = desired length</p>		
<p>art. no.</p> <p>SK 613 ...</p>		
<p>please indicate: ... $\left[\right]$ 37.5 50 75 100 150 1000 mm</p> <p>... custom processing (optional) CNC = individual CNC machining WL = desired length</p>		
<p>art. no.</p> <p>SK 466 ...</p>		
<p>please indicate: ... $\left[\right]$ 50 75 100 150 1000 mm</p> <p>... custom processing (optional) CNC = individual CNC machining WL = desired length</p>		

B

C

D

E

F

G

H

I

K

L

M



Standard extruded heatsinks

B

C

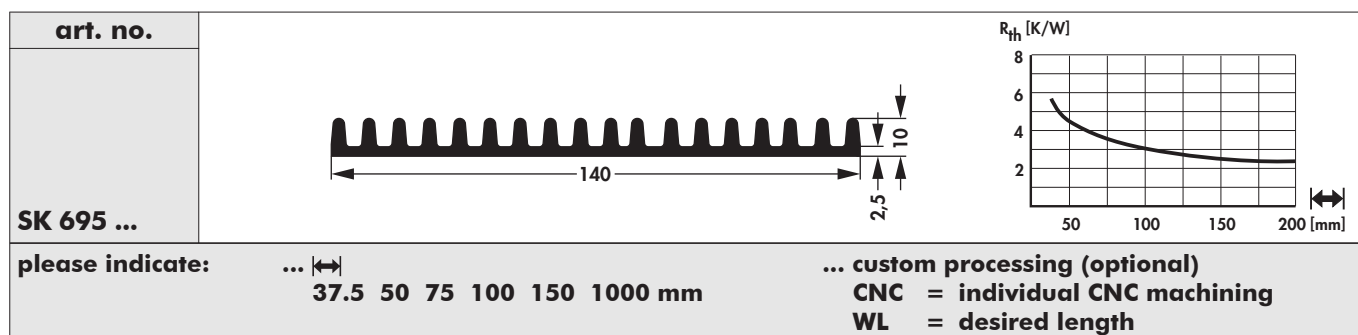

D

E

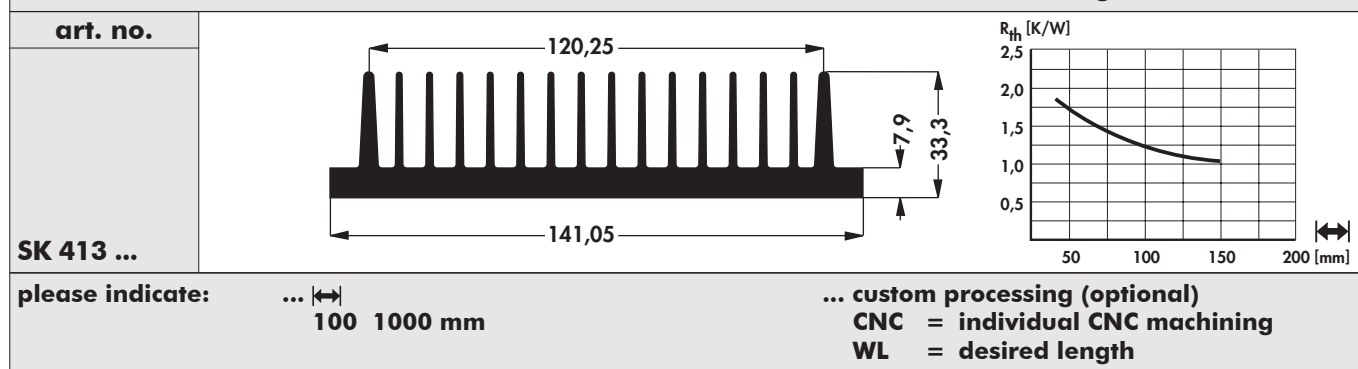

F

G

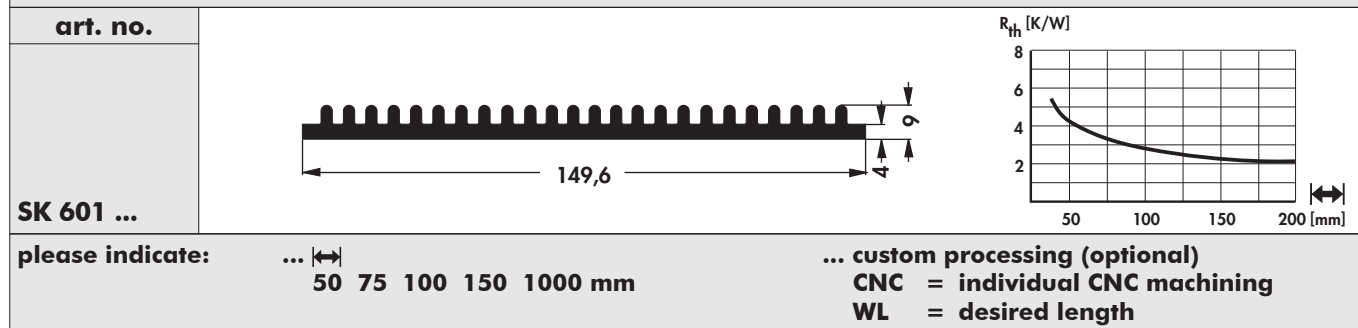

H

I

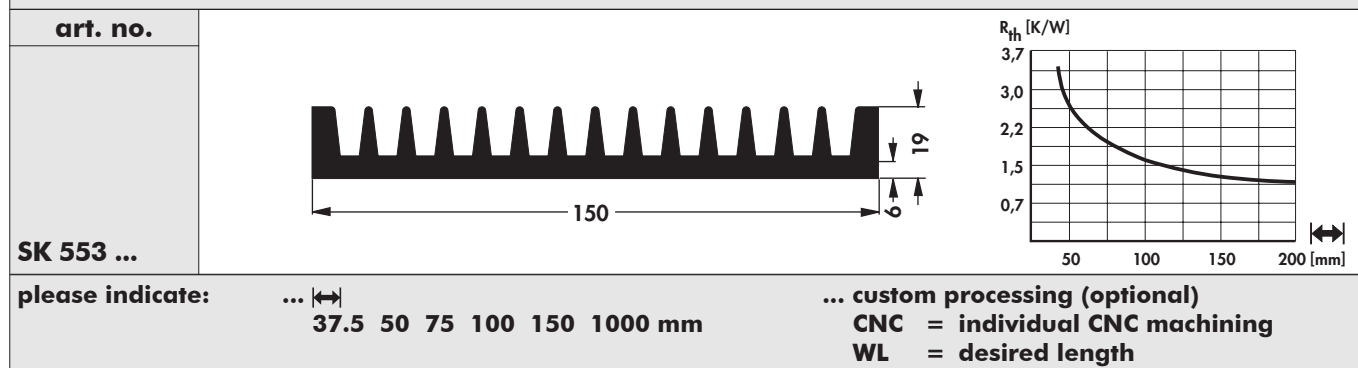

K

L

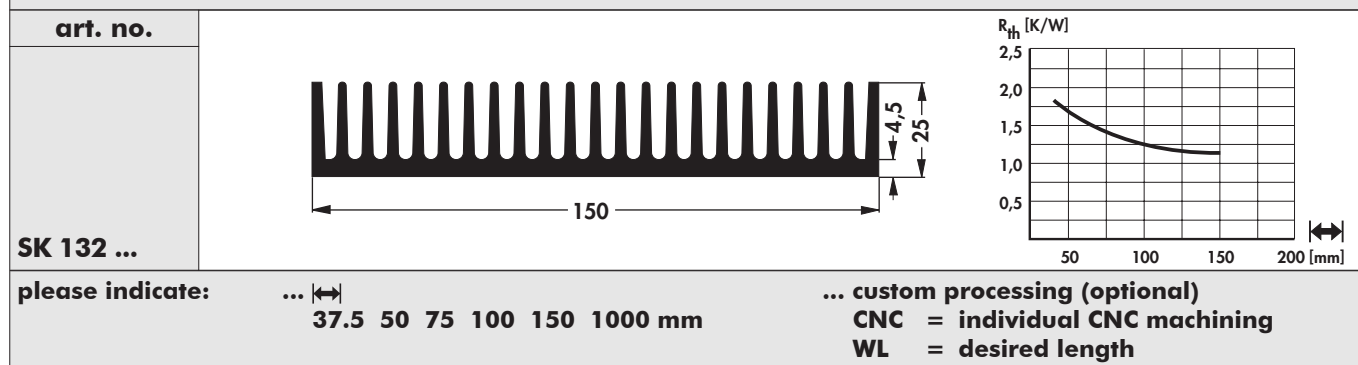

M

N



Standard extruded heatsinks

<p>art. no.</p> <p>SK 410 ...</p>		
<p>please indicate: ... $\left\langle \right\rangle$ 37.5 50 75 100 150 1000 mm ... custom processing (optional) CNC = individual CNC machining WL = desired length</p>		
<p>art. no.</p> <p>SK 133 ...</p>		
<p>please indicate: ... $\left\langle \right\rangle$ 50 75 100 1000 mm ... custom processing (optional) CNC = individual CNC machining WL = desired length</p>		
<p>art. no.</p> <p>SK 58 ...</p>		
<p>please indicate: ... $\left\langle \right\rangle$ 50 75 100 150 1000 mm ... custom processing (optional) CNC = individual CNC machining WL = desired length</p>		
<p>art. no.</p> <p>SK 504 ...</p>		
<p>weight reduced like SK 58</p> <p>please indicate: ... $\left\langle \right\rangle$ 37.5 50 75 100 150 1000 mm ... custom processing (optional) CNC = individual CNC machining WL = desired length</p>		

B

C

D

E

F

G

H

I

K

L

M



N



Standard extruded heatsinks

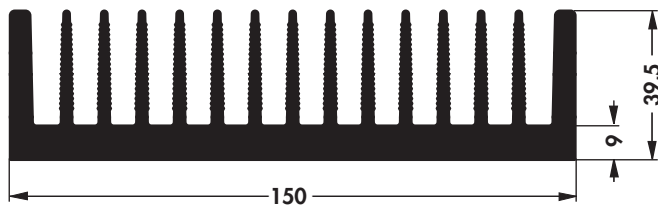
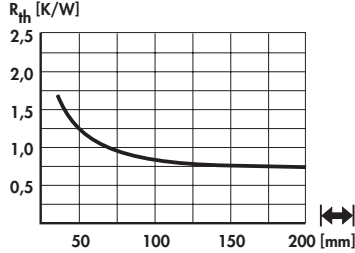

B

C

art. no.		
SK 588 ...		
<p>please indicate: ...  50 75 100 150 1000 mm</p> <p style="text-align: right;">... custom processing (optional) CNC = individual CNC machining WL = desired length</p>		

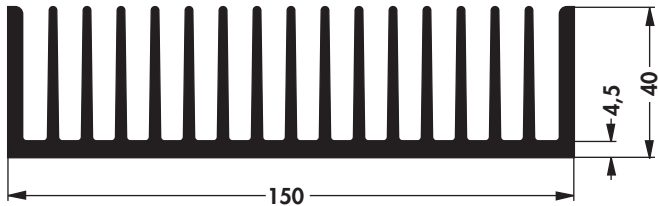
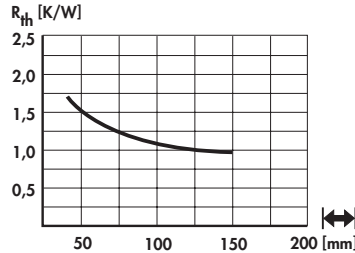

D

E

art. no.		
SK 120 ...		
<p>please indicate: ...  50 75 100 150 1000 mm</p> <p style="text-align: right;">... custom processing (optional) CNC = individual CNC machining WL = desired length</p>		

F

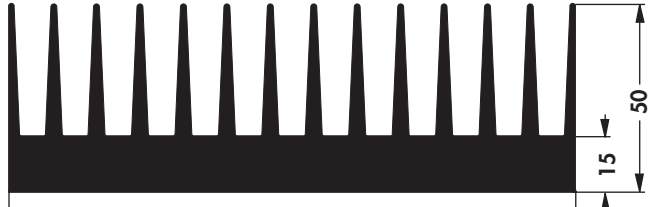
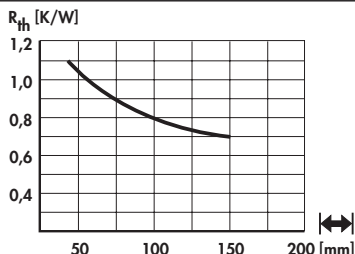

G

art. no.		
SK 155 ...		
<p>please indicate: ...  75 100 150 1000 mm</p> <p style="text-align: right;">... custom processing (optional) CNC = individual CNC machining WL = desired length</p>		

H

I

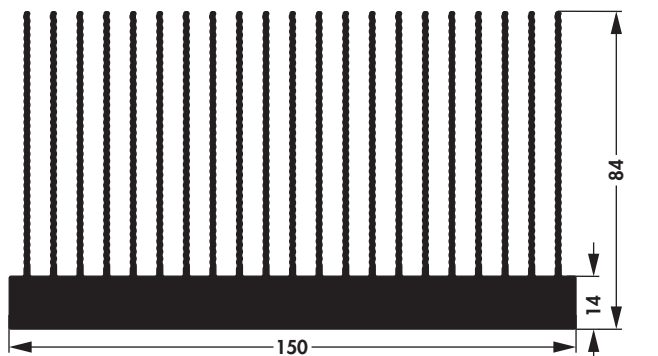
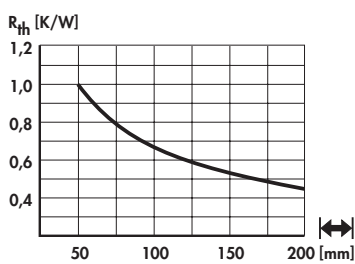
K

art. no.		
SK 710 ...		
<p>please indicate: ...  50 75 100 150 1000 mm</p> <p style="text-align: right;">... custom processing (optional) CNC = individual CNC machining WL = desired length</p>		

L

M



Standard extruded heatsinks

<p>art. no.</p> <p>SK 154 ...</p>		
<p>please indicate: ... $\left[\begin{array}{c} \text{---} \\ \text{---} \end{array} \right]$ 50 75 100 150 mm</p> <p>... custom processing (optional) CNC = individual CNC machining WL = desired length</p>		
<p>art. no.</p> <p>SK 696 ...</p>		
<p>please indicate: ... $\left[\begin{array}{c} \text{---} \\ \text{---} \end{array} \right]$ 37.5 50 75 100 150 1000 mm</p> <p>... custom processing (optional) CNC = individual CNC machining WL = desired length</p>		
<p>art. no.</p> <p>SK 417 ...</p>		
<p>please indicate: ... $\left[\begin{array}{c} \text{---} \\ \text{---} \end{array} \right]$ 75 100 150 1000 mm</p> <p>... custom processing (optional) CNC = individual CNC machining WL = desired length</p>		
<p>art. no.</p> <p>SK 85 ...</p>		
<p>please indicate: ... $\left[\begin{array}{c} \text{---} \\ \text{---} \end{array} \right]$ 37.5 50 75 100 150 1000 mm</p> <p>... custom processing (optional) CNC = individual CNC machining WL = desired length</p>		

B
C
D
E
F
G
H
I
K
L
M
N



Standard extruded heatsinks

B

C

D

E

F

G

H

I

K

L

M

N

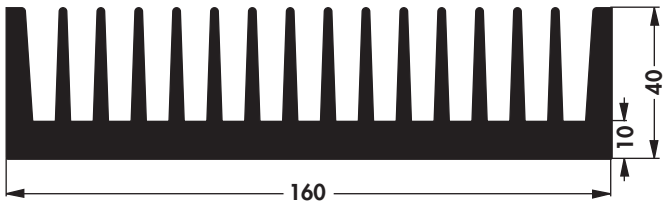
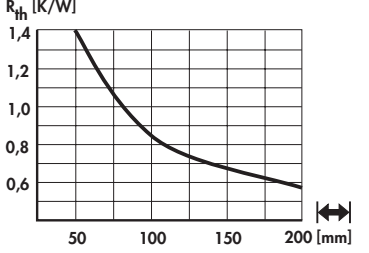
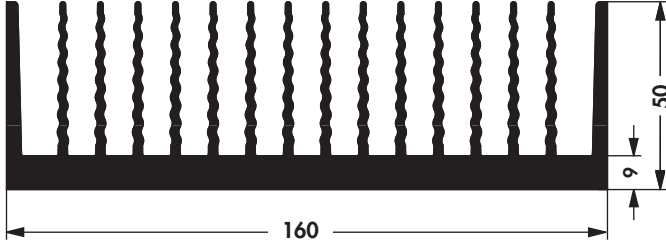
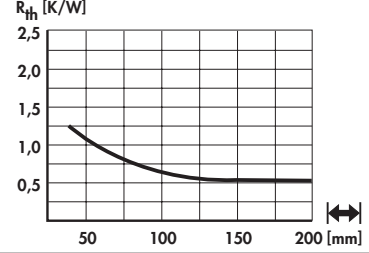
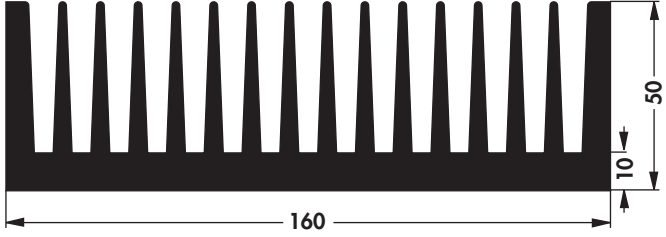
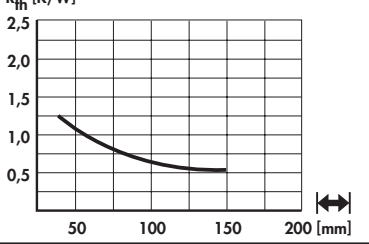
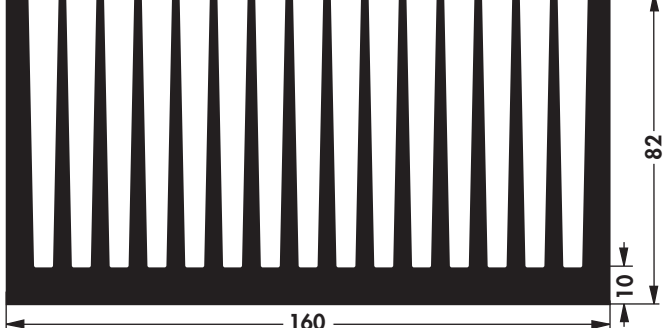
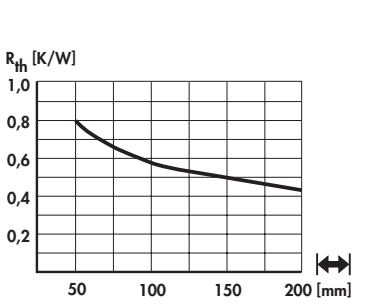
art. no. SK 503 ...			
please indicate: ... $\left[\begin{array}{c} \text{---} \\ \text{---} \end{array} \right]$ 75 100 1000 mm			... custom processing (optional) CNC = individual CNC machining WL = desired length
art. no. SK 510 ...			
please indicate: ... $\left[\begin{array}{c} \text{---} \\ \text{---} \end{array} \right]$ 50 75 100 150 1000 mm			... custom processing (optional) CNC = individual CNC machining WL = desired length
art. no. SK 416 ...			
please indicate: ... $\left[\begin{array}{c} \text{---} \\ \text{---} \end{array} \right]$ 50 75 100 150 200 1000 mm			... custom processing (optional) CNC = individual CNC machining WL = desired length
art. no. SK 627 ...			
please indicate: ... $\left[\begin{array}{c} \text{---} \\ \text{---} \end{array} \right]$ 50 75 100 150 200 1000 mm			... custom processing (optional) CNC = individual CNC machining WL = desired length



Standard extruded heatsinks

<p>art. no.</p> <p>SK 119 ...</p>		
<p>please indicate: ... $\left[\begin{array}{c} \text{---} \\ \text{---} \end{array} \right]$ 50 75 100 150 1000 mm</p> <p>... custom processing (optional) CNC = individual CNC machining WL = desired length</p>		
<p>art. no.</p> <p>SK 412 ...</p>		
<p>please indicate: ... $\left[\begin{array}{c} \text{---} \\ \text{---} \end{array} \right]$ 50 75 100 150 1000 mm</p> <p>... custom processing (optional) CNC = individual CNC machining WL = desired length</p>		
<p>art. no.</p> <p>SK 421 ...</p>		
<p>please indicate: ... $\left[\begin{array}{c} \text{---} \\ \text{---} \end{array} \right]$ 50 75 100 150 200 1000 mm</p> <p>... custom processing (optional) CNC = individual CNC machining WL = desired length</p>		
<p>art. no.</p> <p>SK 405 ...</p>		
<p>please indicate: ... $\left[\begin{array}{c} \text{---} \\ \text{---} \end{array} \right]$ 100 1000 mm</p> <p>... custom processing (optional) CNC = individual CNC machining WL = desired length</p>		

B
C
D
E
F
G
H
I
K
L
M
N



Standard extruded heatsinks

B

C

D

E

F

G

H

I

K

L

M

N

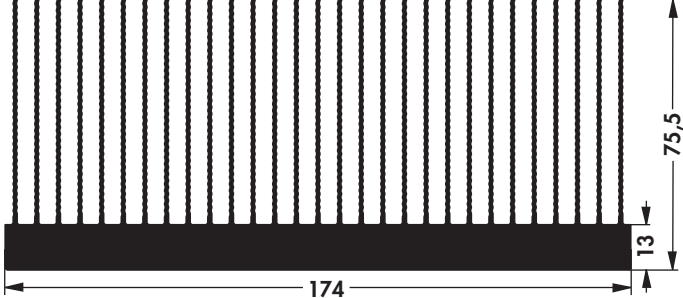
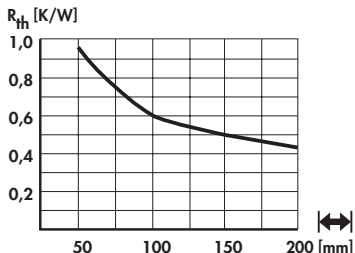
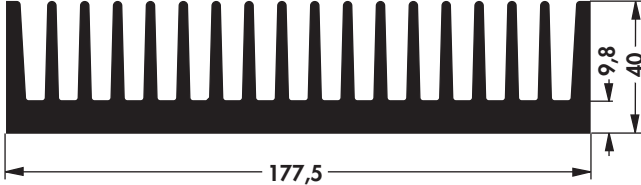
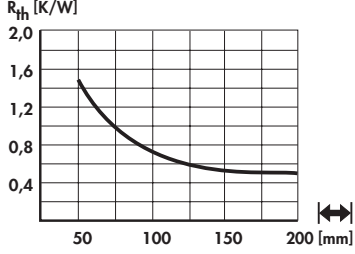
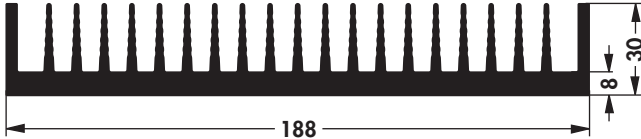
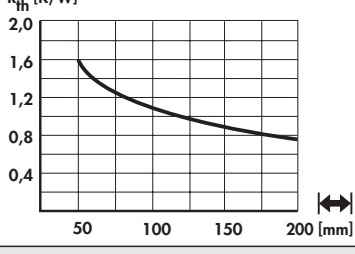
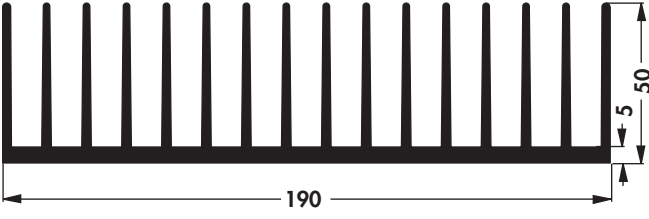
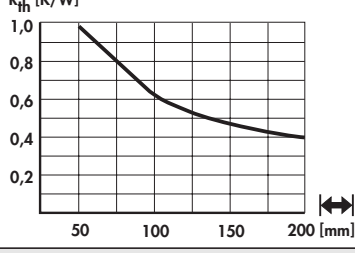
art. no. SK 623 ...		
<p>please indicate: ... $\left[\begin{array}{c} \text{---} \\ \text{---} \end{array} \right]$ 50 75 100 150 1000 mm</p> <p>... custom processing (optional) CNC = individual CNC machining WL = desired length</p>		
art. no. SK 519 ...		
<p>please indicate: ... $\left[\begin{array}{c} \text{---} \\ \text{---} \end{array} \right]$ 50 100 1000 mm</p> <p>... custom processing (optional) CNC = individual CNC machining WL = desired length</p>		
art. no. SK 629 ...		
<p>please indicate: ... $\left[\begin{array}{c} \text{---} \\ \text{---} \end{array} \right]$ 50 75 100 150 1000 mm</p> <p>... custom processing (optional) CNC = individual CNC machining WL = desired length</p>		
art. no. SK 90 ...		
<p>please indicate: ... $\left[\begin{array}{c} \text{---} \\ \text{---} \end{array} \right]$ 50 75 100 1000 mm</p> <p>... custom processing (optional) CNC = individual CNC machining WL = desired length</p>		

Standard extruded heatsinks

<p>art. no.</p> <p>SK 136 ...</p>		
<p>please indicate: ... $\left[\begin{array}{c} \text{---} \\ \text{---} \end{array} \right]$ 75 100 150 1000 mm</p> <p>... custom processing (optional) CNC = individual CNC machining WL = desired length</p>		
<p>art. no.</p> <p>SK 166 ...</p>		
<p>please indicate: ... $\left[\begin{array}{c} \text{---} \\ \text{---} \end{array} \right]$ 1000 mm</p> <p>... custom processing (optional) CNC = individual CNC machining WL = desired length</p>		
<p>art. no.</p> <p>SK 113 ...</p>		
<p>please indicate: ... $\left[\begin{array}{c} \text{---} \\ \text{---} \end{array} \right]$ 50 75 100 150 1000 mm</p> <p>... custom processing (optional) CNC = individual CNC machining WL = desired length</p>		
<p>art. no.</p> <p>SK 42 ...</p>		
<p>please indicate: ... $\left[\begin{array}{c} \text{---} \\ \text{---} \end{array} \right]$ 50 75 100 150 200 1000 mm</p> <p>... custom processing (optional) CNC = individual CNC machining WL = desired length</p>		
<p>art. no.</p> <p>SK 94 ...</p>		
<p>please indicate: ... $\left[\begin{array}{c} \text{---} \\ \text{---} \end{array} \right]$ 1000 mm</p> <p>... custom processing (optional) CNC = individual CNC machining WL = desired length</p>		

B

C

D

E

F

G

H

I

K

L

M

N



Standard extruded heatsinks

<p>art. no.</p> <p>SK 502 ...</p> <p>weight reduced like SK 47</p>		
<p>please indicate: ... $\left[\begin{array}{c} \text{---} \\ \text{---} \end{array} \right]$ 37.5 50 75 100 150 1000 mm</p> <p>... custom processing (optional) CNC = individual CNC machining WL = desired length</p>		
<p>art. no.</p> <p>SK 707 ...</p>		
<p>please indicate: ... $\left[\begin{array}{c} \text{---} \\ \text{---} \end{array} \right]$ 50 75 100 150 1000 mm</p> <p>... custom processing (optional) CNC = individual CNC machining WL = desired length</p>		
<p>art. no.</p> <p>SK 47 ...</p>		
<p>please indicate: ... $\left[\begin{array}{c} \text{---} \\ \text{---} \end{array} \right]$ 75 100 150 1000 mm</p> <p>... custom processing (optional) CNC = individual CNC machining WL = desired length</p>		
<p>art. no.</p> <p>SK 591 ...</p>		
<p>please indicate: ... $\left[\begin{array}{c} \text{---} \\ \text{---} \end{array} \right]$ 75 100 150 1000 mm</p> <p>... custom processing (optional) CNC = individual CNC machining WL = desired length</p>		



Standard extruded heatsinks

<p>art. no.</p> <p>SK 711 ...</p>		
<p>please indicate: ... $\left[\right]$ 50 75 100 150 200 1000 mm</p> <p>... custom processing (optional) CNC = individual CNC machining WL = desired length</p>		
<p>art. no.</p> <p>SK 700 ...</p>		
<p>please indicate: ... $\left[\right]$ 75 100 150 200 1000 mm</p> <p>... custom processing (optional) CNC = individual CNC machining WL = desired length</p>		
<p>art. no.</p> <p>SK 520 ...</p>		
<p>please indicate: ... $\left[\right]$ 75 100 150 1000 mm</p> <p>... custom processing (optional) CNC = individual CNC machining WL = desired length</p>		
<p>art. no.</p> <p>SK 193 ...</p>		
<p>please indicate: ... $\left[\right]$ 100 150 1000 mm</p> <p>... custom processing (optional) CNC = individual CNC machining WL = desired length</p>		

B

C

D

E

F

G

H

I

K

L

M

N

Standard extruded heatsinks

B

C

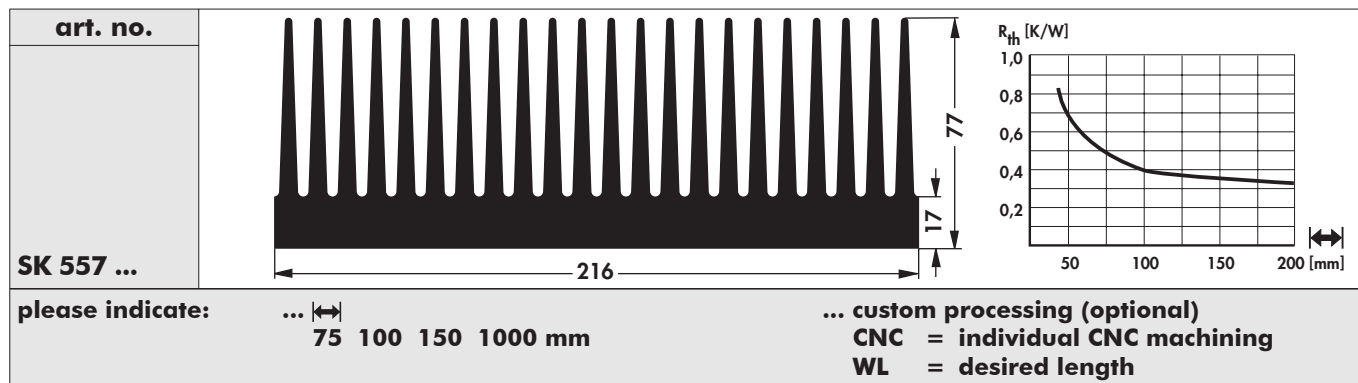

D

E

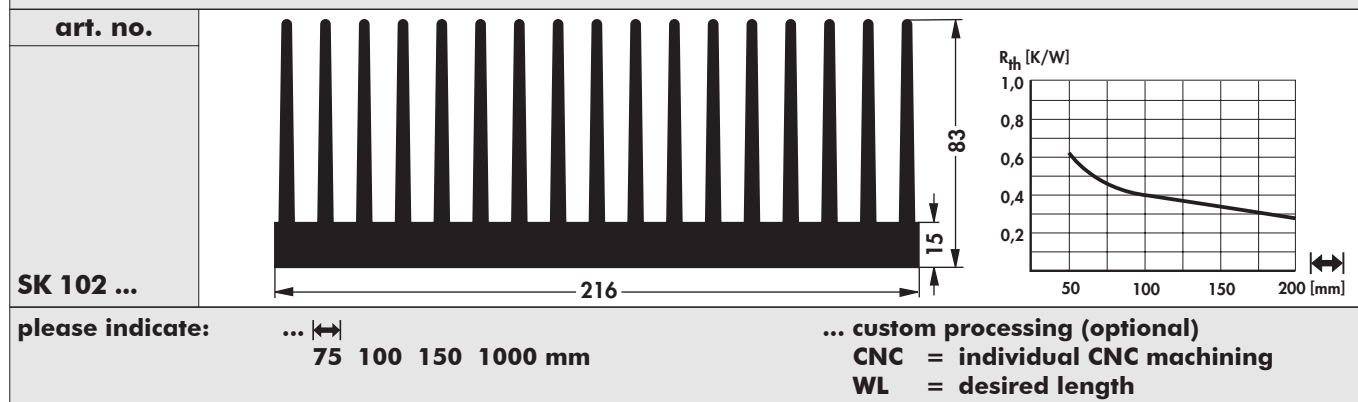

F

G

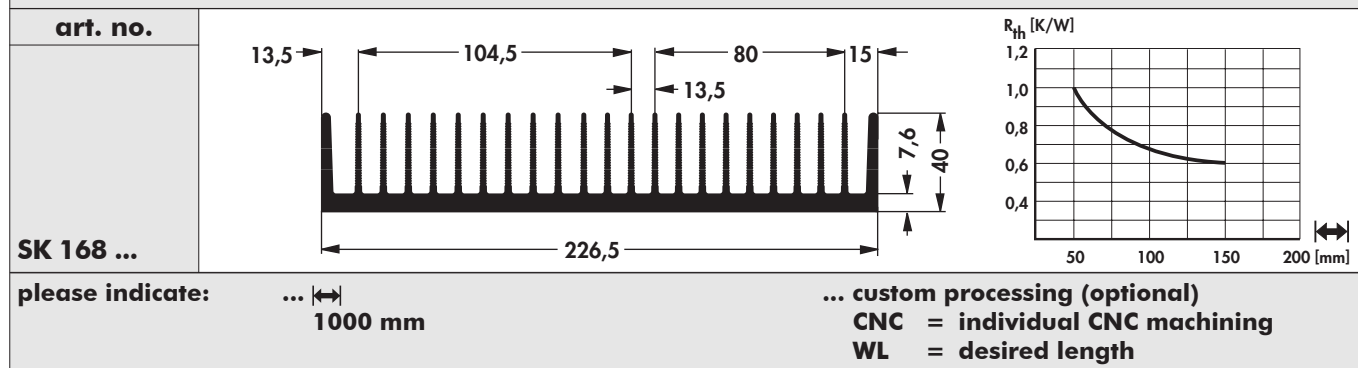

H

I

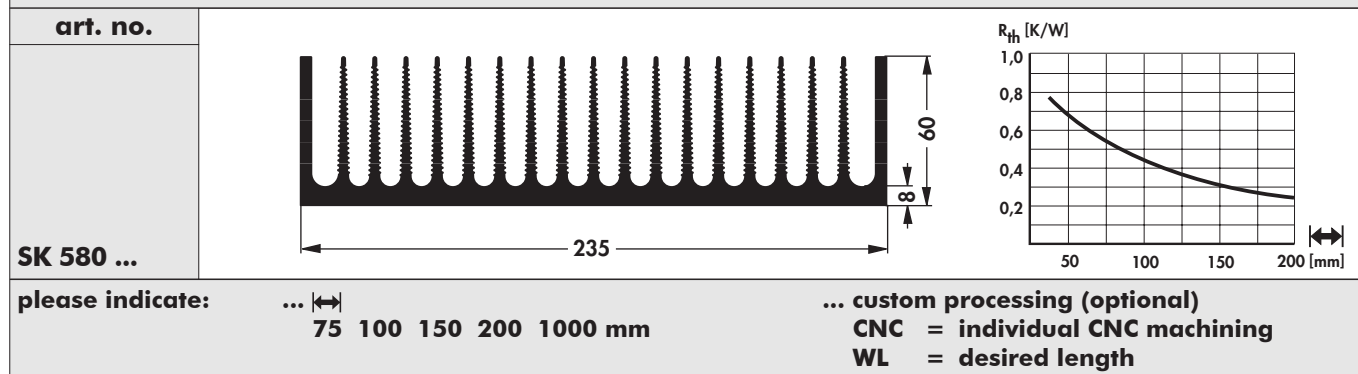

K

L

M

N



Standard extruded heatsinks

<p>art. no.</p> <p>SK 118 ...</p>		
<p>please indicate: ... $\left[\begin{array}{c} \text{---} \\ \text{---} \end{array} \right]$ 75 100 150 1000 mm</p> <p>... custom processing (optional) CNC = individual CNC machining WL = desired length</p>		
<p>art. no.</p> <p>SK 49 ...</p>		
<p>please indicate: ... $\left[\begin{array}{c} \text{---} \\ \text{---} \end{array} \right]$ 50 75 150 200 1000 mm</p> <p>... custom processing (optional) CNC = individual CNC machining WL = desired length</p>		
<p>art. no.</p> <p>SK 199 ...</p>		
<p>please indicate: ... $\left[\begin{array}{c} \text{---} \\ \text{---} \end{array} \right]$ 75 100 1000 mm</p> <p>... custom processing (optional) CNC = individual CNC machining WL = desired length</p>		
<p>art. no.</p> <p>SK 555 ...</p>		
<p>please indicate: ... $\left[\begin{array}{c} \text{---} \\ \text{---} \end{array} \right]$ 75 100 150 1000 mm</p> <p>... custom processing (optional) CNC = individual CNC machining WL = desired length</p>		
<p>art. no.</p> <p>SK 524 ...</p>		
<p>please indicate: ... $\left[\begin{array}{c} \text{---} \\ \text{---} \end{array} \right]$ 75 100 150 1000 mm</p> <p>... custom processing (optional) CNC = individual CNC machining WL = desired length</p>		

B

C

D

E

F

G

H

I

K

L

M



Standard extruded heatsinks

B

C

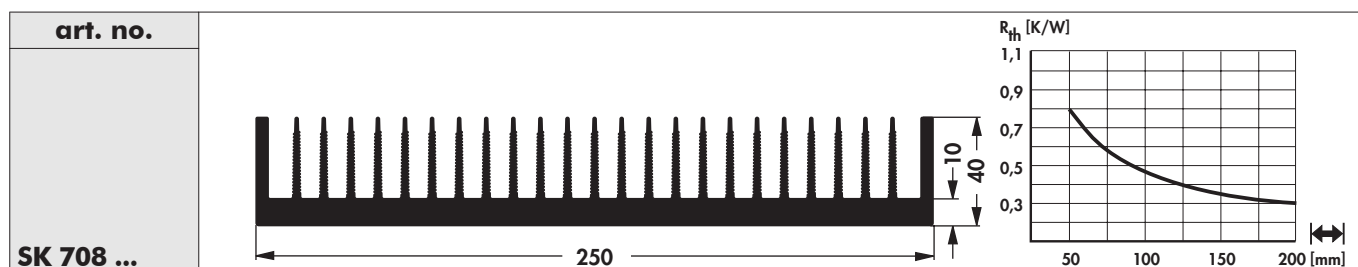

please indicate:

 ... 
 75 100 150 200 1000 mm

... custom processing (optional)

 CNC = individual CNC machining
 WL = desired length

D

E

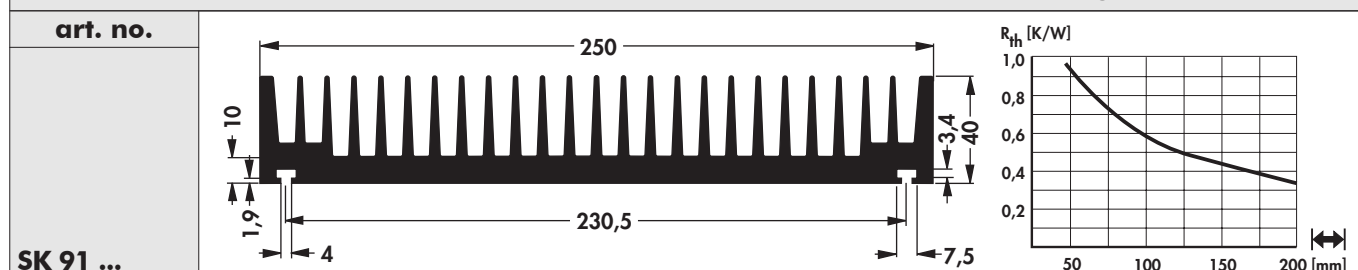

please indicate:

 ... 
 75 100 150 1000 mm

... custom processing (optional)

 CNC = individual CNC machining
 WL = desired length

F

G

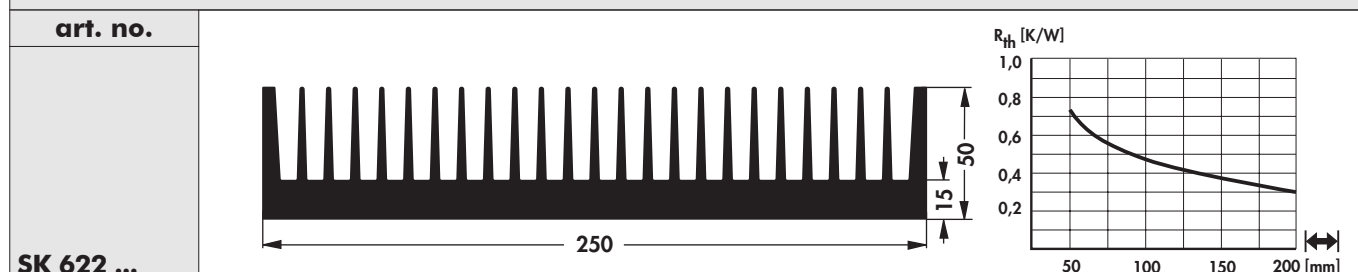

please indicate:

 ... 
 75 100 150 200 1000 mm

... custom processing (optional)

 CNC = individual CNC machining
 WL = desired length

H

I

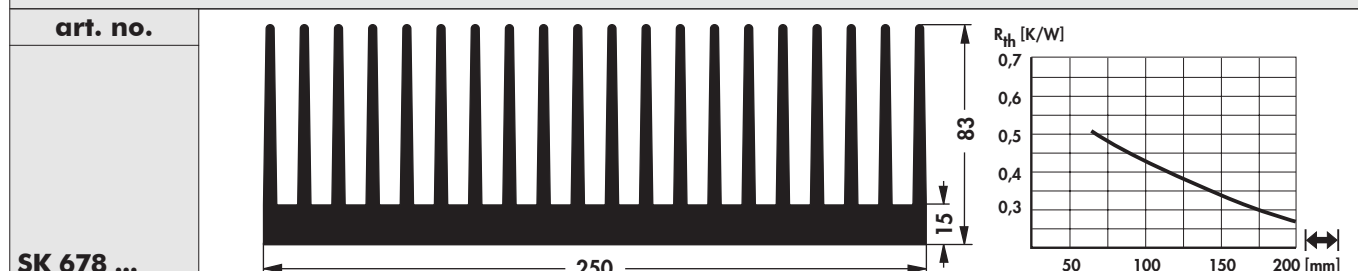

please indicate:

 ... 
 75 100 150 1000 mm

... custom processing (optional)

 CNC = individual CNC machining
 WL = desired length







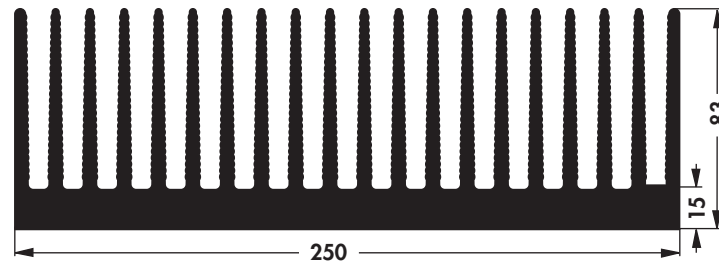
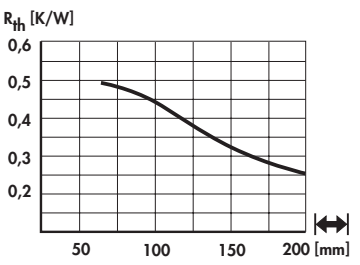

L

M

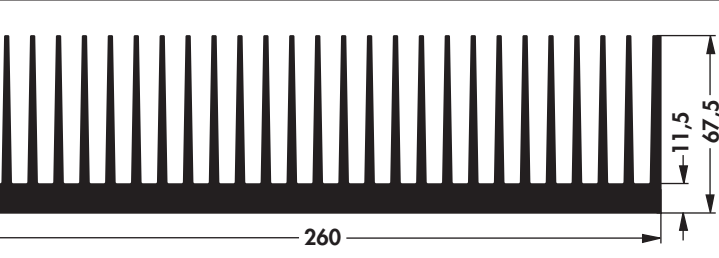
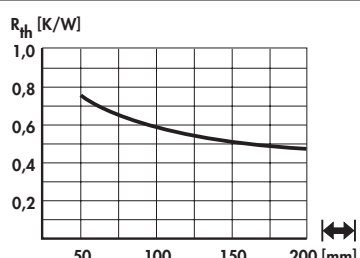
N

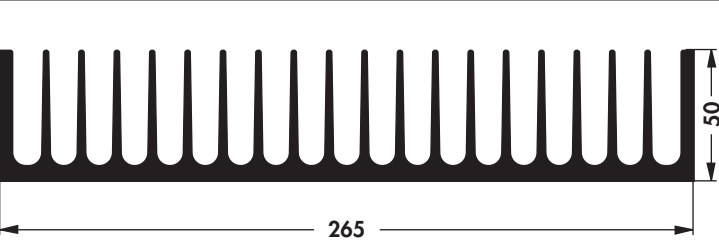
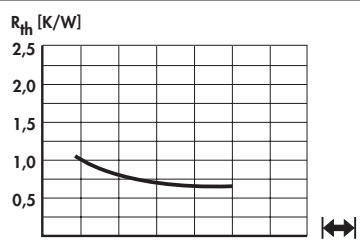

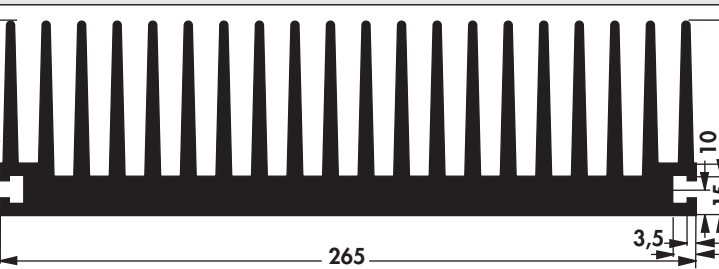
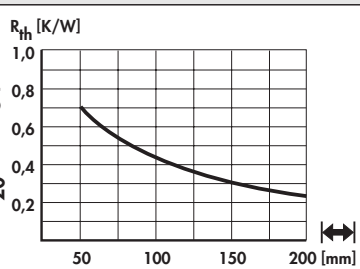
Standard extruded heatsinks

<p>art. no.</p> <p>SK 438 ...</p>		
<p>please indicate: ...  75 100 150 1000 mm</p> <p>... custom processing (optional) CNC = individual CNC machining WL = desired length</p>		
<p>art. no.</p> <p>SK 614 ...</p>		
<p>please indicate: ...  75 100 150 200 1000 mm</p> <p>... custom processing (optional) CNC = individual CNC machining WL = desired length</p>		
<p>art. no.</p> <p>SK 149 ...</p>		
<p>please indicate: ...  200 1000 mm</p> <p>... custom processing (optional) CNC = individual CNC machining WL = desired length</p>		
<p>art. no.</p> <p>SK 139 ...</p>		
<p>please indicate: ...  100 150 200 1000 mm</p> <p>... custom processing (optional) CNC = individual CNC machining WL = desired length</p>		

B

C

D

E

F

G

H

I

K

L

M

N



Standard extruded heatsinks

art. no.

SK 583 ...

please indicate: ... $\left[\begin{array}{c} | \\ | \\ | \end{array} \right]$ 100 150 200 1000 mm

... custom processing (optional)
CNC = individual CNC machining
WL = desired length

art. no.

SK 682 ...

please indicate: ... $\left[\begin{array}{c} | \\ | \\ | \end{array} \right]$ 100 150 200 1000 mm

... custom processing (optional)
CNC = individual CNC machining
WL = desired length

art. no.

SK 689 ...

please indicate: ... $\left[\begin{array}{c} | \\ | \\ | \end{array} \right]$ 75 100 150 200 1000 mm

... custom processing (optional)
CNC = individual CNC machining
WL = desired length

art. no.

SK 198 ...

please indicate: ... $\left[\begin{array}{c} | \\ | \\ | \end{array} \right]$ 100 150 1000 mm

... custom processing (optional)
CNC = individual CNC machining
WL = desired length

art. no.

SK 671 ...

please indicate: ... $\left[\begin{array}{c} | \\ | \\ | \end{array} \right]$ 50 75 100 150 200 1000 mm

... custom processing (optional)
CNC = individual CNC machining
WL = desired length



Standard extruded heatsinks

<p>art. no.</p> <p>SK 446 ...</p>		
<p>please indicate: ... \longleftrightarrow 75 100 150 1000 mm</p> <p>... custom processing (optional) CNC = individual CNC machining WL = desired length</p>		
<p>art. no.</p> <p>SK 56 ...</p>		
<p>please indicate: ... \longleftrightarrow 75 100 150 200 1000 mm</p> <p>... custom processing (optional) CNC = individual CNC machining WL = desired length</p>		
<p>art. no.</p> <p>SK 501 ...</p>		
<p>weight reduced like SK 56</p>		
<p>please indicate: ... \longleftrightarrow 37.5 50 75 100 150 200 1000 mm</p> <p>... custom processing (optional) CNC = individual CNC machining WL = desired length</p>		
<p>art. no.</p> <p>SK 568 ...</p>		
<p>please indicate: ... \longleftrightarrow 75 100 150 200 1000 mm</p> <p>... custom processing (optional) CNC = individual CNC machining WL = desired length</p>		

B
C
D
E
F
G
H
I
K
L
M
N



Standard extruded heatsinks

B

C

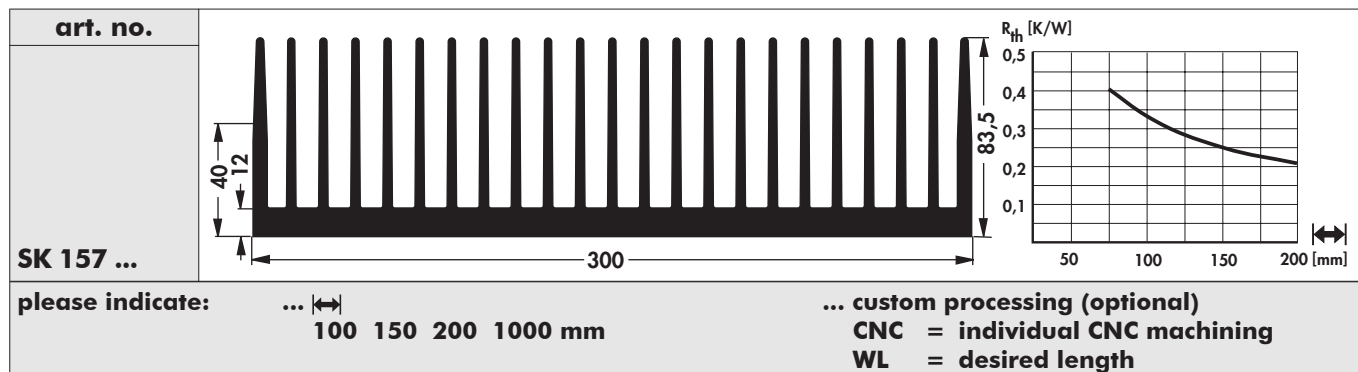

D

E

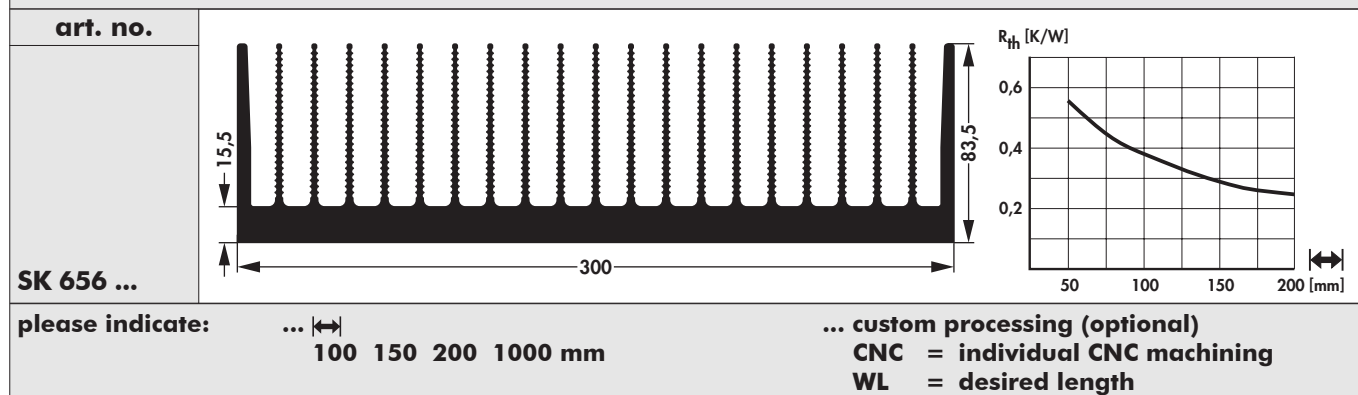

F

G

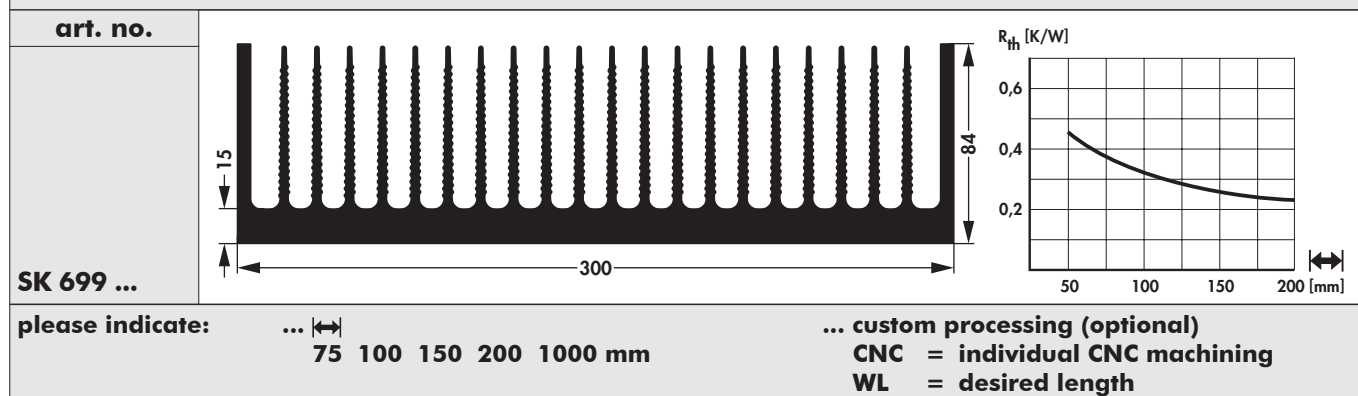

H

I

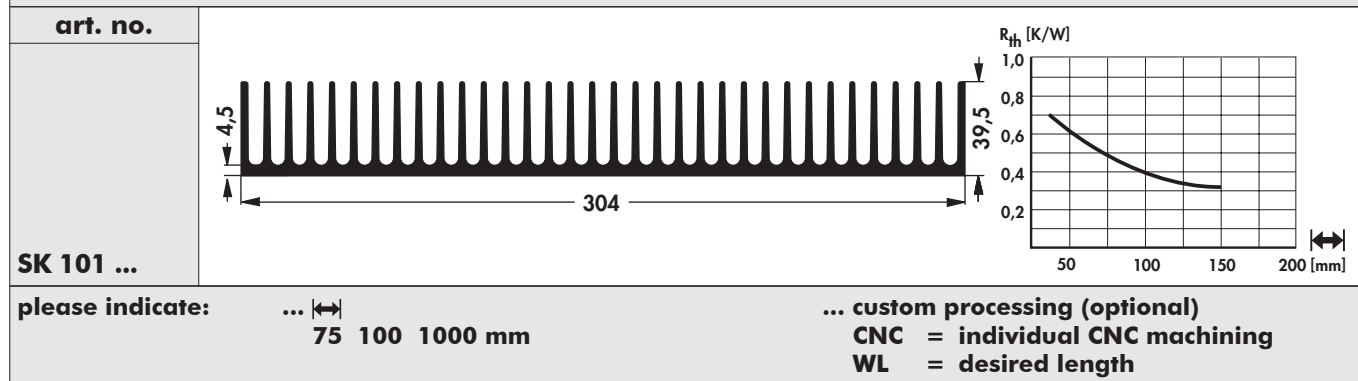

K

L

M

N



Standard extruded heatsinks

<p>art. no.</p> <p>SK 579 ...</p>		
<p>please indicate: ... $\left[\begin{array}{c} \text{---} \\ \text{---} \end{array} \right]$ 75 100 150 200 1000 mm</p> <p>... custom processing (optional) CNC = individual CNC machining WL = desired length</p>		
<p>art. no.</p> <p>SK 66 ...</p>		
<p>please indicate: ... $\left[\begin{array}{c} \text{---} \\ \text{---} \end{array} \right]$ 75 100 1000 mm</p> <p>... custom processing (optional) CNC = individual CNC machining WL = desired length</p>		
<p>art. no.</p> <p>SK 523 ...</p>		
<p>please indicate: ... $\left[\begin{array}{c} \text{---} \\ \text{---} \end{array} \right]$ 100 150 200 1000 mm</p> <p>... custom processing (optional) CNC = individual CNC machining WL = desired length</p>		
<p>art. no.</p> <p>SK 439 ...</p>		
<p>please indicate: ... $\left[\begin{array}{c} \text{---} \\ \text{---} \end{array} \right]$ 100 150 1000 mm</p> <p>... custom processing (optional) CNC = individual CNC machining WL = desired length</p>		
<p>art. no.</p> <p>SK 685 ...</p>		
<p>please indicate: ... $\left[\begin{array}{c} \text{---} \\ \text{---} \end{array} \right]$ 100 150 200 1000 mm</p> <p>... custom processing (optional) CNC = individual CNC machining WL = desired length</p>		

B

C

D

E

F

G

H

I

K

L

M



Standard extruded heatsinks

B

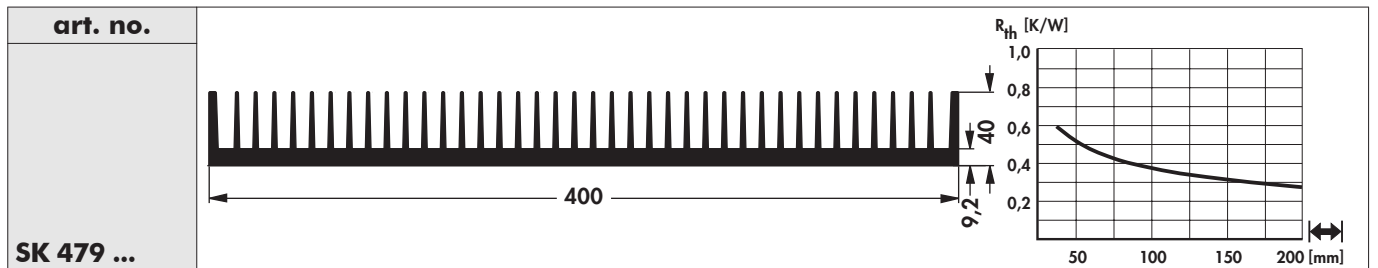

please indicate: ...  **75 100 150 1000 mm**

... **custom processing (optional)**
CNC = individual CNC machining
WL = desired length

D

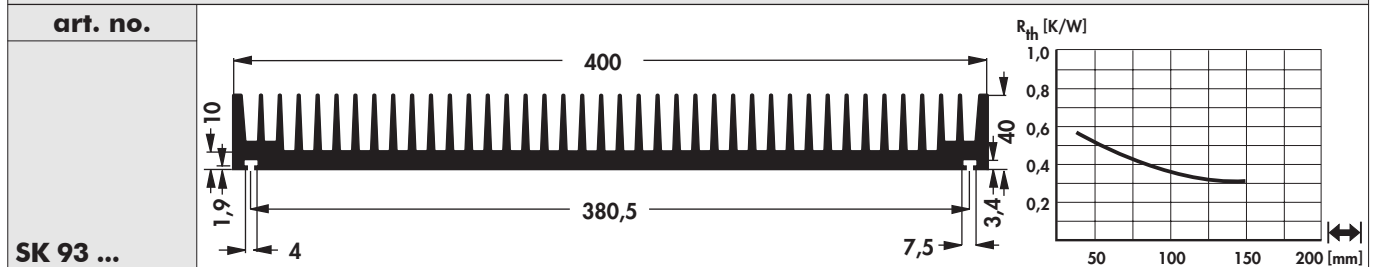

please indicate: ...  **75 100 150 1000 mm**

... **custom processing (optional)**
CNC = individual CNC machining
WL = desired length

F

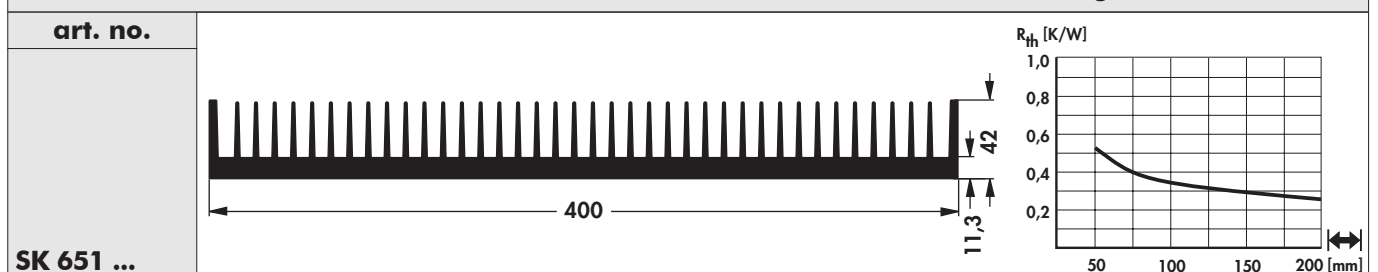

please indicate: ...  **75 100 150 200 1000 mm**

... **custom processing (optional)**
CNC = individual CNC machining
WL = desired length

H

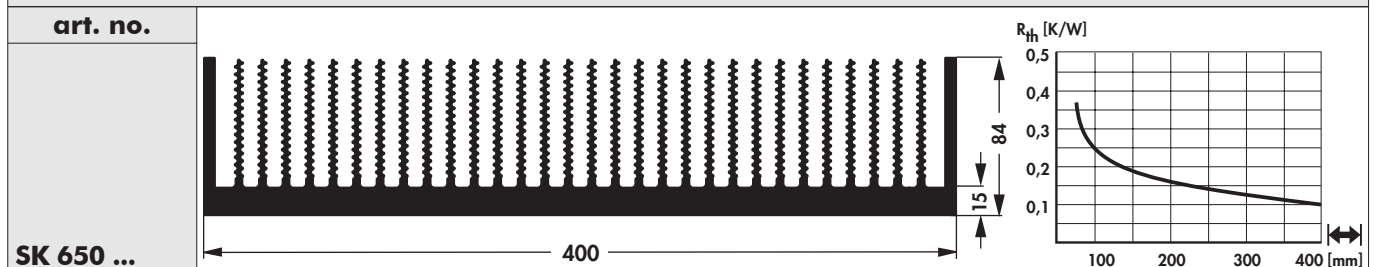

please indicate: ...  **150 200 300 400 1000 mm**

... **custom processing (optional)**
CNC = individual CNC machining
WL = desired length

K

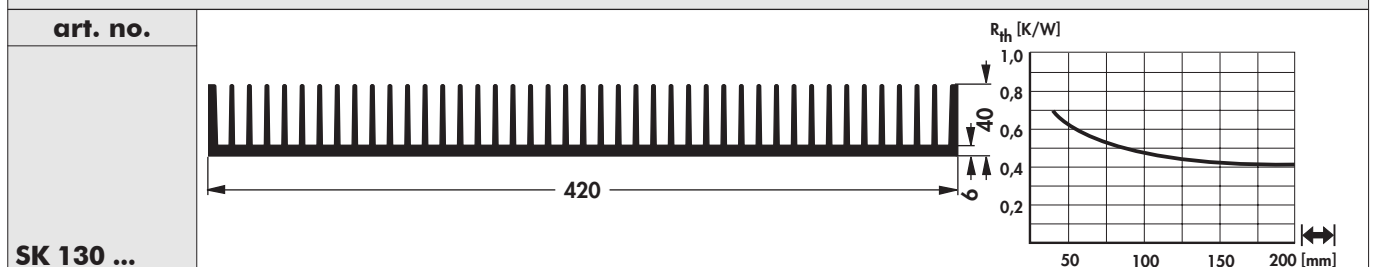







please indicate: ...  **200 1000 mm**

... **custom processing (optional)**
CNC = individual CNC machining
WL = desired length

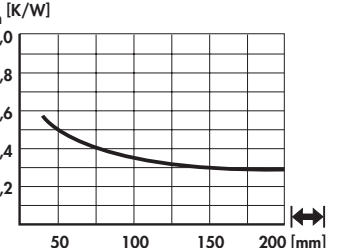
M

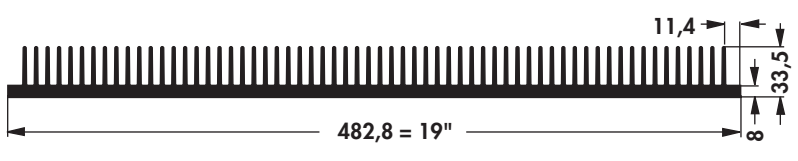
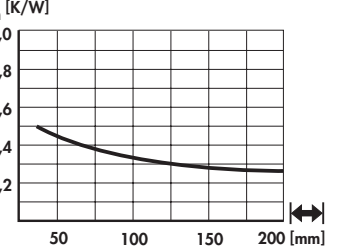

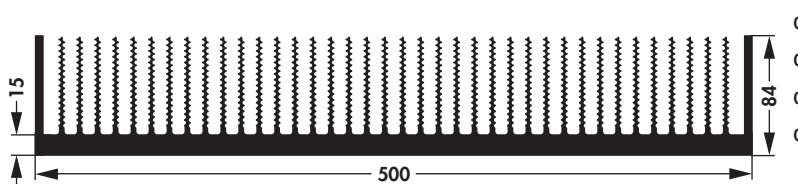
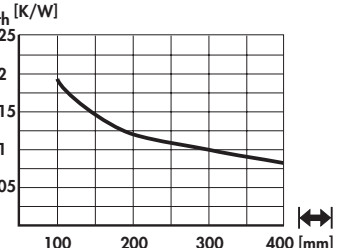
Standard extruded heatsinks

<p>art. no.</p> <p>SK 621 ...</p>		
<p>please indicate: ...  75 100 150 200 1000 mm</p> <p>... custom processing (optional) CNC = individual CNC machining WL = desired length</p>		
<p>art. no.</p> <p>SK 191 ...</p>		
<p>suitable heatsink for rear panel in 19" cases</p> <p>please indicate: ...  75 100 150 200 1000 mm</p> <p>... custom processing (optional) CNC = individual CNC machining WL = desired length</p>		
<p>art. no.</p> <p>SK 673 ...</p>		
<p>minimum order quantity 1500 kg; samples on request</p> <p>please indicate: ...  150 200 300 400 1000 mm</p> <p>... custom processing (optional) CNC = individual CNC machining WL = desired length</p>		

B
C
D
E
F
G
H
I
K
L
M
N



Welded high performance heatsinks

- optimum fin geometry and fin quantity for free convection
- well suited for forced convection
- flat milled base (not SK 530, SK 531)
- * = welded joint (not SK 530, SK 531)
- length according customer's details
- customer specific versions and machining on request

SK 530; SK 533 - SK 540

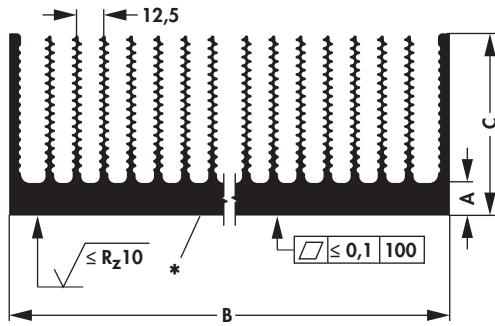

SK 531

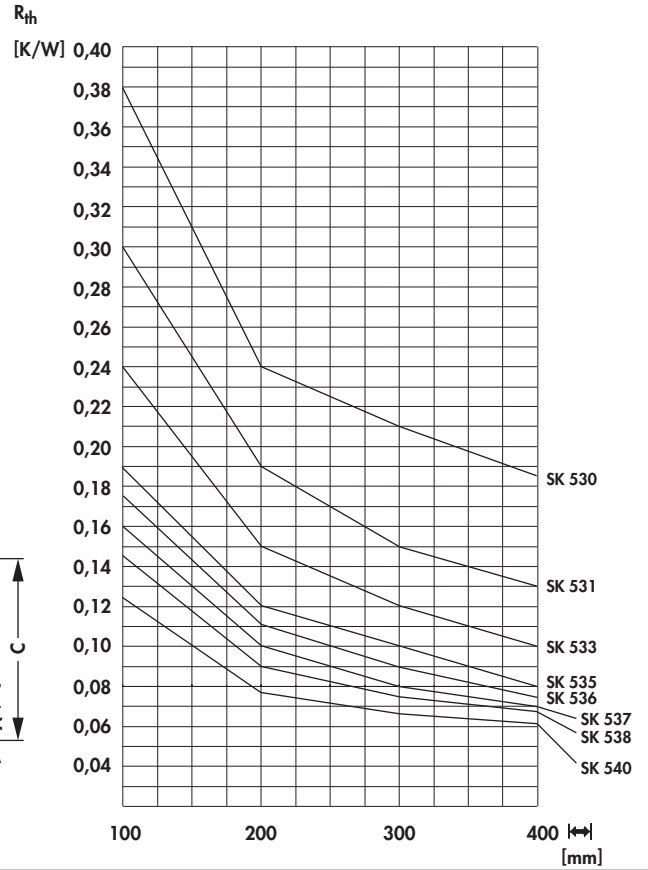
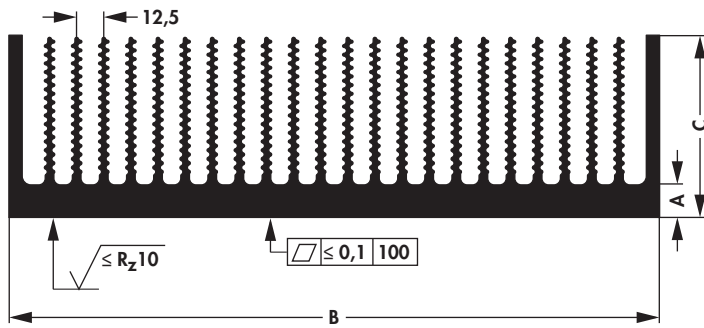

art. no.	number of fins	dim. [mm]		
		A	B	C
SK 530 ...	14	15 ±0.7	200 ±0.7	84 ±0.7
SK 531 ...	22		300 ±1.0	
SK 533 ...	30	16 +0.0/-1.5	400 +0.6/-1.6	84 +0.0/-1.5
SK 535 ...	38		500 +0.6/-1.6	
SK 536 ...	42		550 +0.6/-1.6	
SK 537 ...	46		600 +0.6/-1.6	
SK 538 ...	50		650 +0.6/-1.6	
SK 540 ...	58		750 +0.6/-1.6	
please indicate:		... [mm] 200 300 400 500 600 mm		

High performance heatsinks with press-in fins

- other length according to customer's details
- customer specific versions and machining upon request

art. no.

SK 418 ...

please indicate: ... \longleftrightarrow 100 150 200 1000 mm

... custom processing (optional)
CNC = individual CNC machining
WL = desired length

art. no.	number of fins	dim. [mm]	
		A	B
SK 158 ...	22	20	300 ± 2.0
SK 159 ...	30		400 ± 2.0
SK 160 ...	38		500 ± 2.5
SK 161 ...	46		600 ± 3.0
SK 162 ...	58		750 ± 4.0

please indicate: ... \longleftrightarrow 200 300 400 500 600 mm

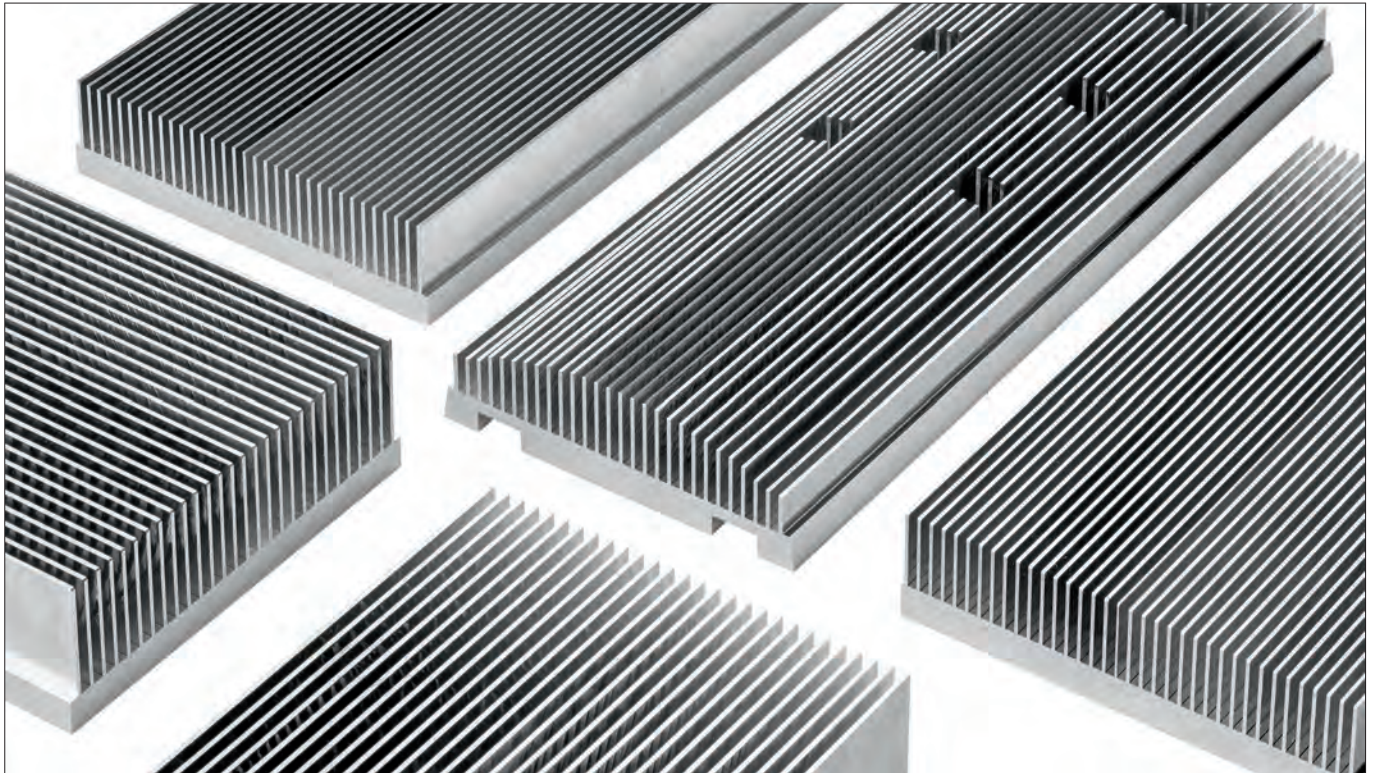

- effective heatsink solutions machined out of solid aluminium material
- precise milled flat surfaces with very low surface roughness
- for free and forced convection
- very small thermal resistance
- designs made of copper material, different sizes, dimensions and special designs upon request

<p>art. no.</p> <p>KGR 1 ...</p>		<p>100 mm</p>	
<p>art. no.</p> <p>KGR 2 ...</p>		<p>150 mm</p>	
<p>please indicate: ... <math>\leftrightarrow</math> 50 75 100 150 200 1000 mm</p>		<p>... custom processing (optional) CNC = individual CNC machining WL = desired length</p>	
<p>material:</p>		<p>aluminium EN AW 6082</p>	

Heatsinks KGR customised

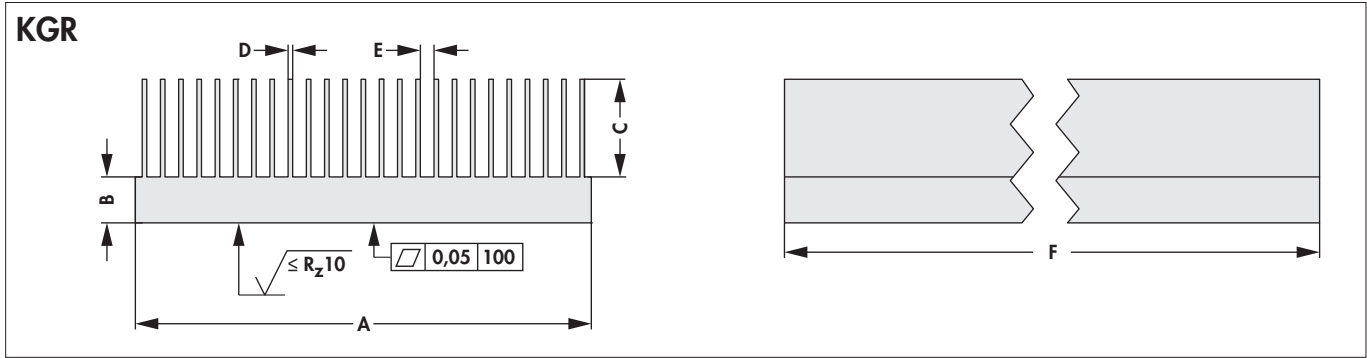

possible dimensions:

dimensions [mm]					
A	B	C	D	E	F
max. 250	min. 4/max. 20	max. 38	min. 0,8	2 / 2.5 / 3 / 4 / 5	max. 1500

please indicate with your order:

dimensions [mm]					
A	B	C	D	E	F
material:		depending on the dimension: aluminium EN AW 6060 or EN AW 6082, version in copper upon request			

B

C

D

E

F

G

H

I

K

L

M

Skiving heatsinks KSK

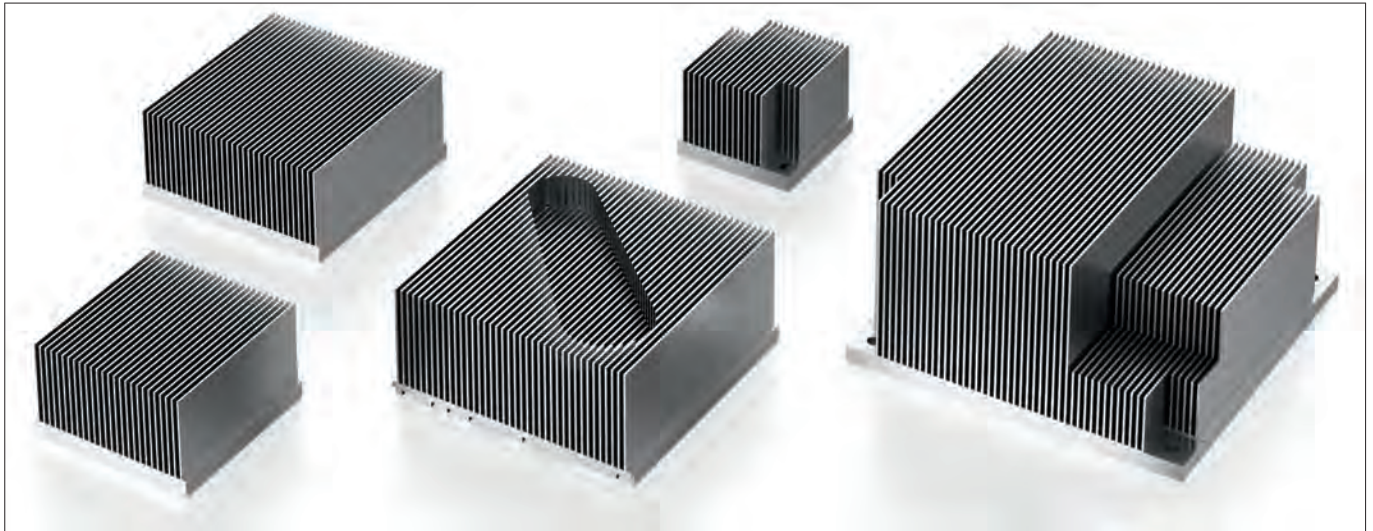

- skiving heatsink with exactly milled flat semiconductor mounting surface and low roughness depths
- particularly suitable for thermoelectric and similar power modules
- optimal heat transfer resistance from the base plate to the individual fins, as the heatsinks are made from one piece of material
- very good heat conducting aluminum material EN AW 1050 A
- extremely compact and high fin density for forced convection
- great design flexibility and fast prototyping
- skived heatsinks made of copper material on request
- heatsink width = length
- additional mechanical processing, other designs and dimensions according to customer-specific requirements

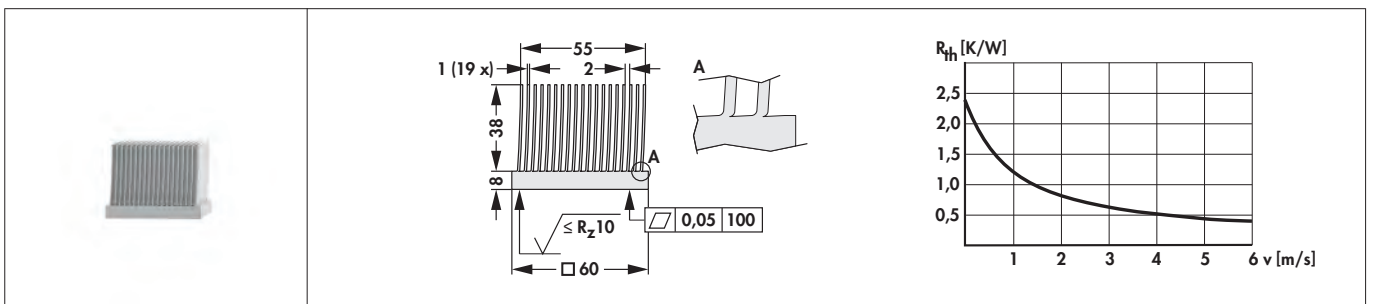





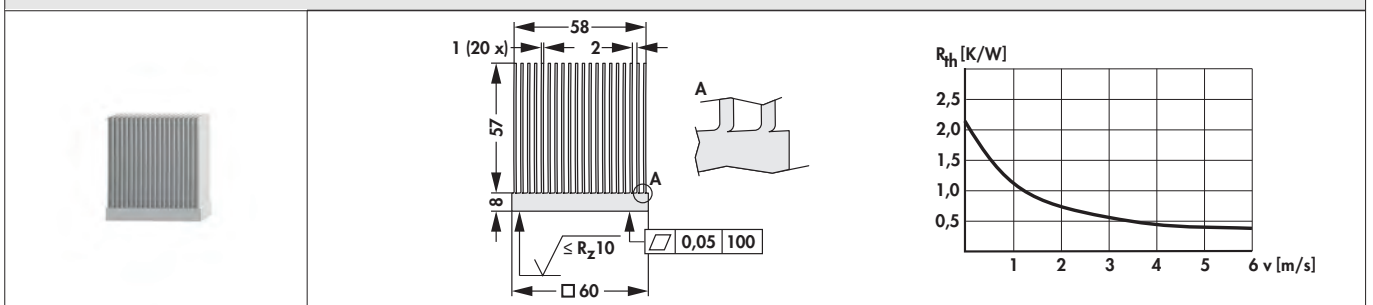

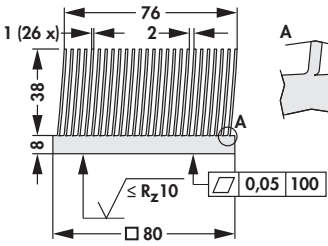
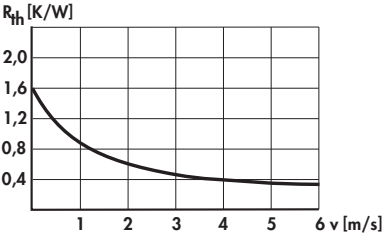

art. no.

KSK 1

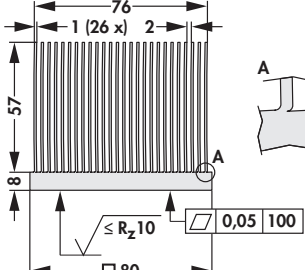
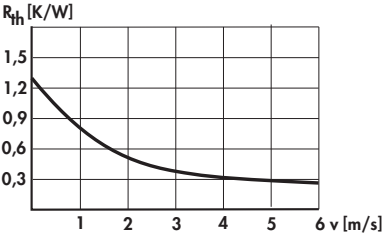

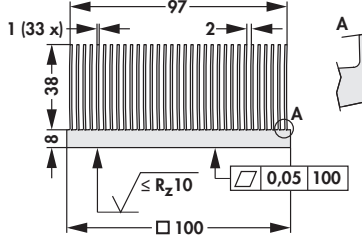
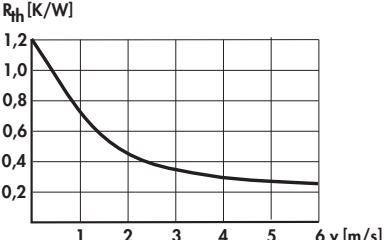
art. no.

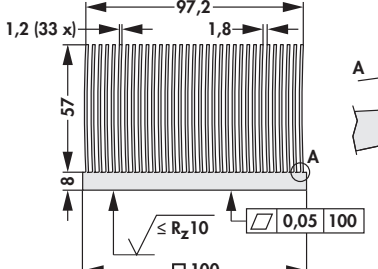
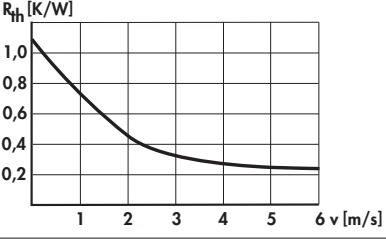
KSK 2

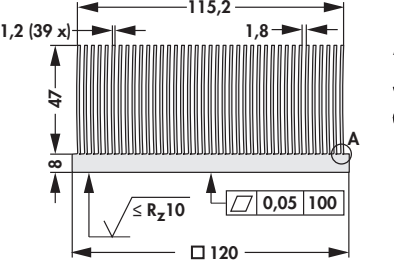
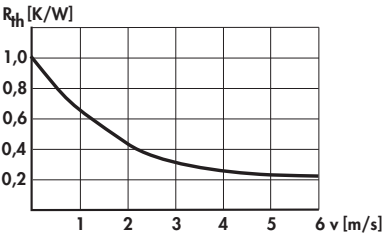
		
art. no.		
KSK 3		
		
art. no.		
KSK 4		
		
art. no.		
KSK 5		
		
art. no.		
KSK 6		
		
art. no.		
KSK 7		

Skiving heatsinks KSK

B

C

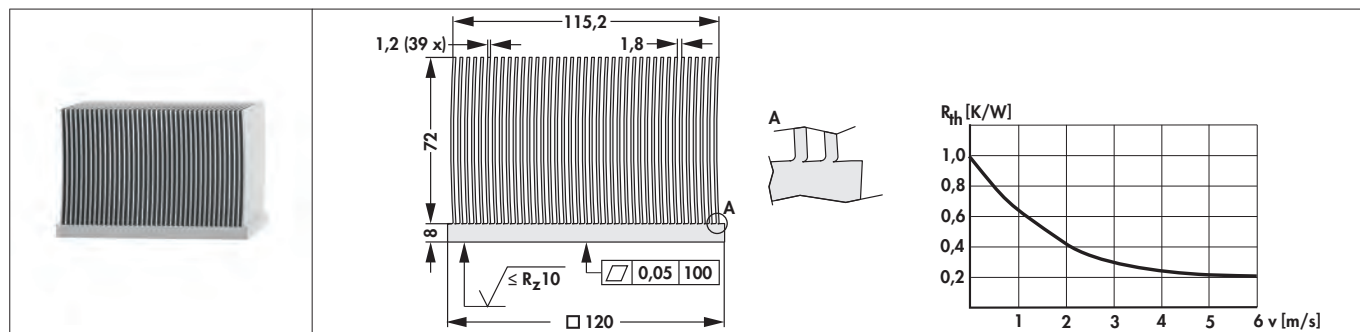

art. no.

KSK 8

D

E

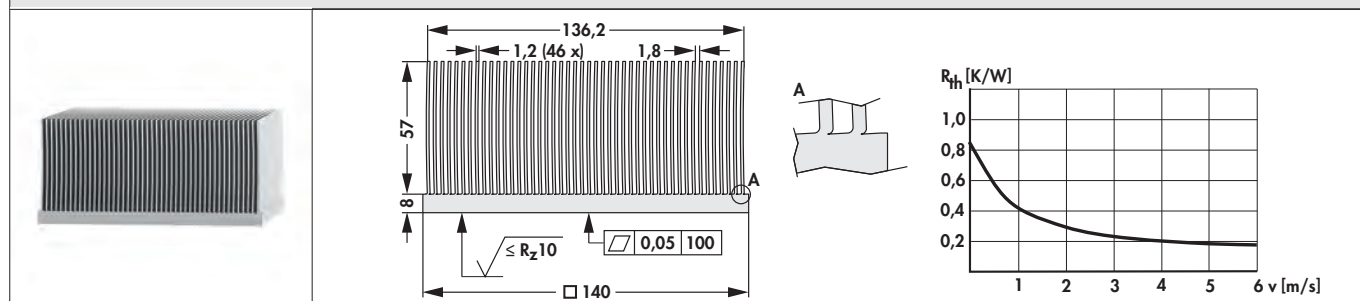

art. no.

KSK 9

F

G

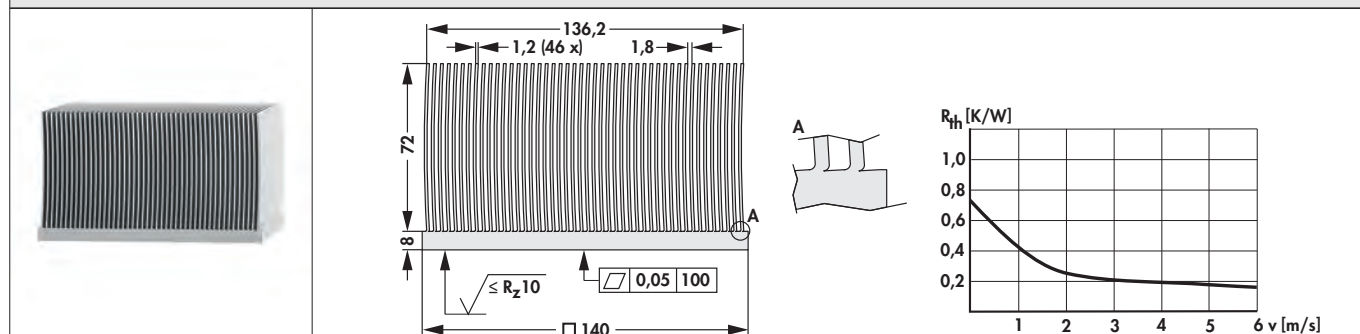

art. no.

KSK 10

H

I

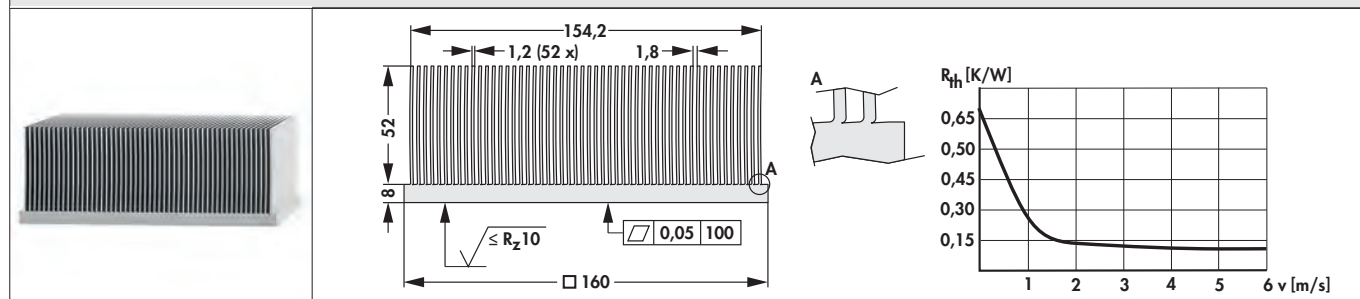

art. no.

KSK 11

L

M

N

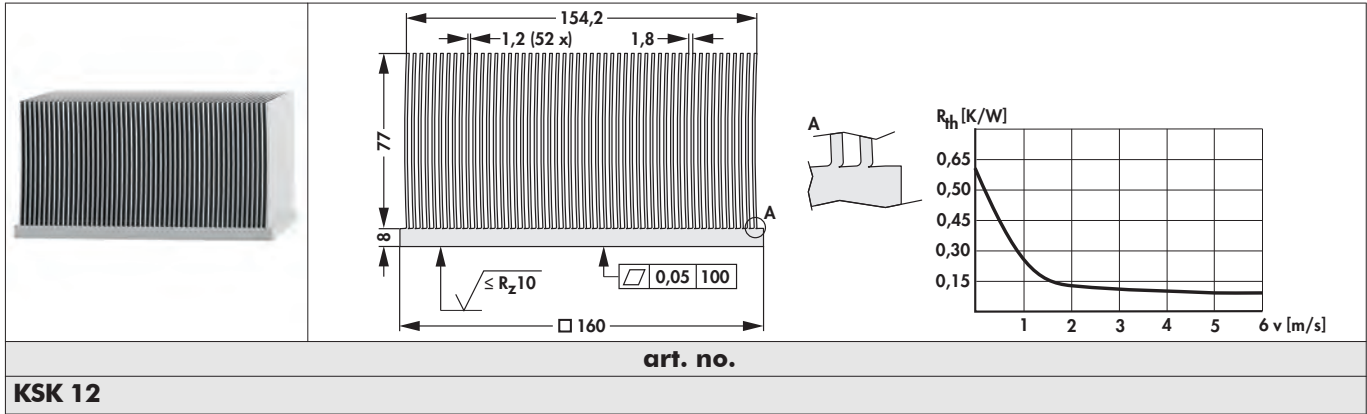

For customised heatsinks please specify the dimensions when ordering:

– the dimension E depends on the design and the ratio of fin thickness and fin spacing

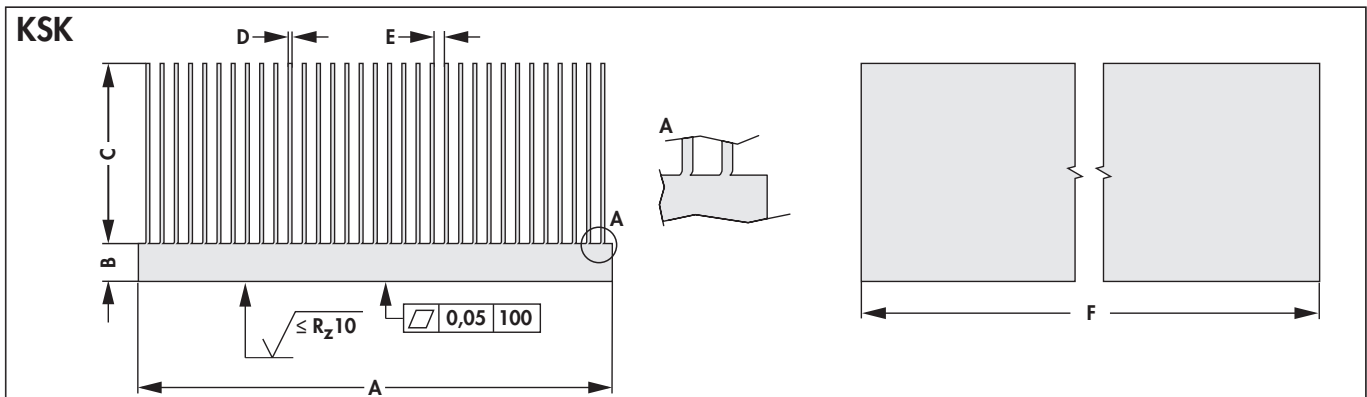

possible dimensions:

dimensions [mm]					
A	B	C	D	E	F
max. 1150	8 - 40	max. 120	0.8 - 1.4	0.5 - 10	max. 580

please indicate with your order:

dimensions [mm]					
A	B	C	D	E	F







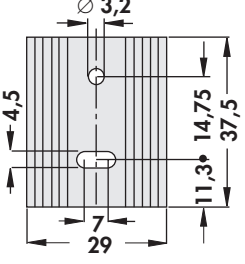
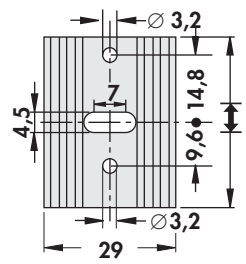
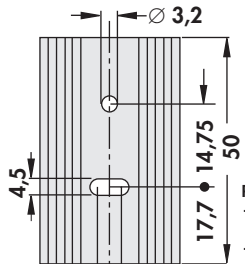
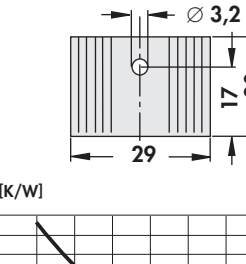
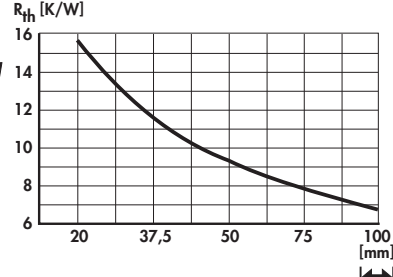
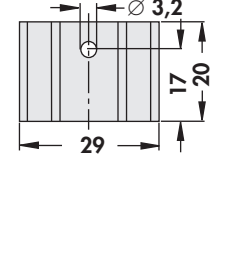
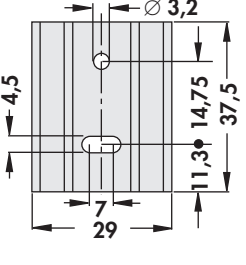
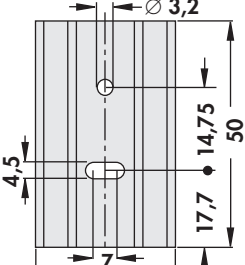
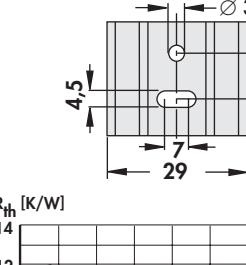
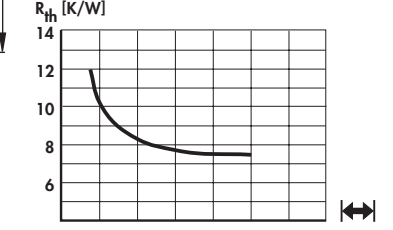
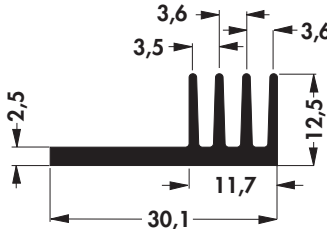
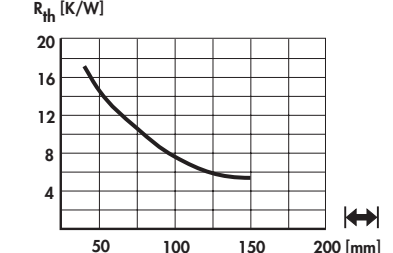

material: EN AW 1050 A; other materials on request

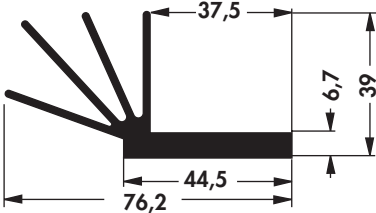
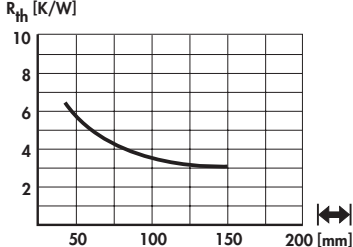

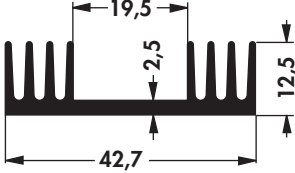
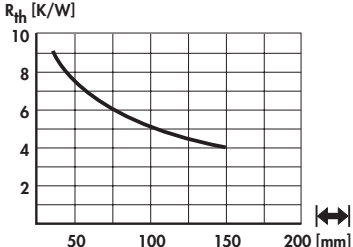
Standard extruded heatsinks

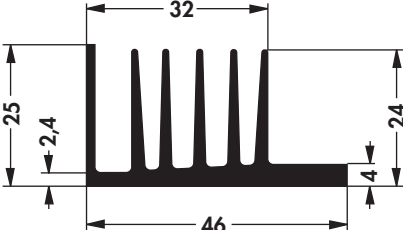
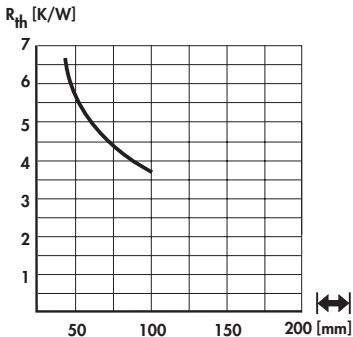
<p>art. no.</p>	<p>SK 09 37,5 TO 220</p> 	<p>SK 09 37,5 TO 220 1 SK 09 50,0 TO 220 1</p> 	<p>SK 09 50 TO 220</p> 	<p>SK 09 20 TO 220</p>  
<p>SK 09 ...</p> <p>please indicate: ... \lceil 20 37.5 50 1000 mm ... \diamond (optional) K; TO 220; TO 220 1</p> <p>... custom processing (optional) CNC = individual CNC machining WL = desired length</p>				
<p>art. no.</p>	<p>SK 145 20 TO 220</p> 	<p>SK 145 37,5 TO 220</p> 	<p>SK 145 50 TO 220</p> 	<p>SK 145 25 TO 220</p>  
<p>SK 145 ...</p> <p>please indicate: ... \lceil 20 25 37.5 50 1000 mm ... \diamond (optional) TO 220</p> <p>... custom processing (optional) CNC = individual CNC machining WL = desired length</p>				
<p>art. no.</p>				
<p>SK 443 ...</p> <p>please indicate: ... \lceil 37.5 75 100 1000 mm ... custom processing (optional) CNC = individual CNC machining WL = desired length</p>				

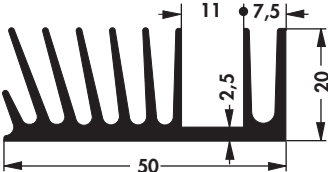
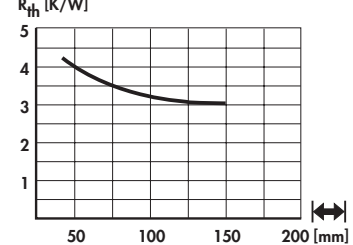
Standard extruded heatsinks

<p>art. no.</p> <p>SK 173 ...</p>		
<p>please indicate: ...  1000 mm</p>		<p>... custom processing (optional) CNC = individual CNC machining WL = desired length</p>
<p>art. no.</p> <p>SK 59 ...</p>		
<p>please indicate: ...  37.5 50 75 100 1000 mm</p> <p>... custom processing (optional) CNC = individual CNC machining WL = desired length</p>		<p>...  (optional) TO 220</p>
<p>art. no.</p> <p>SK 107 ...</p>		
<p>please indicate: ...  50 75 100 1000 mm</p>		<p>... custom processing (optional) CNC = individual CNC machining WL = desired length</p>
<p>art. no.</p> <p>SK 181 ...</p>		
<p>please indicate: ...  50 75 100 1000 mm</p>		<p>... custom processing (optional) CNC = individual CNC machining WL = desired length</p>

B

C

D

E

F

G

H

I

K

L

M

N

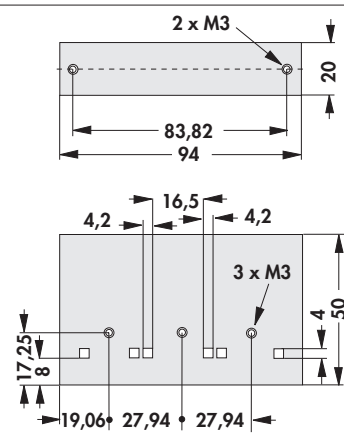
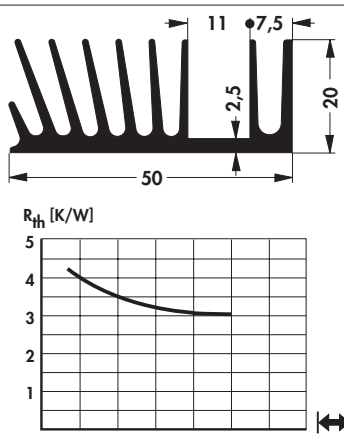

Standard extruded heatsinks

art. no.	 <p>SK 181 94 C 3 x TO 220</p>		
-----------------	--	--	---

SK 181 94 C 3 x TO 220

retaining spring for transistor THF 409 TO 220 → A 158

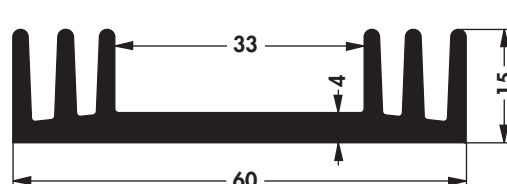
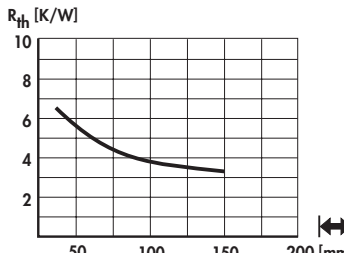
art. no.		
-----------------	--	---

SK 78 ...

please indicate:

... $\left[\right]$
37.5 50 75 100 1000 mm

... \diamond (optional)
TO 3; CB

... custom processing (optional)
CNC = individual CNC machining
WL = desired length

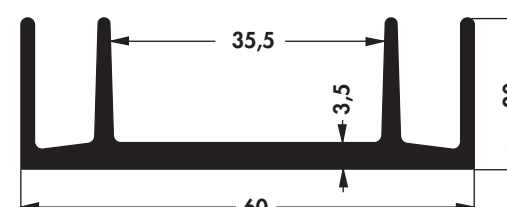
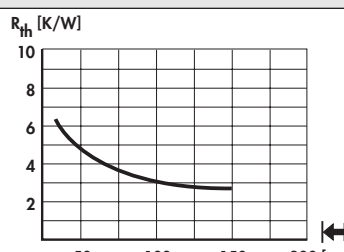
art. no.		
-----------------	---	---

SK 51 ...

please indicate:

... $\left[\right]$
37.5 50 75 100 1000 mm

... \diamond (optional)
TO 3; CB

... custom processing (optional)
CNC = individual CNC machining
WL = desired length

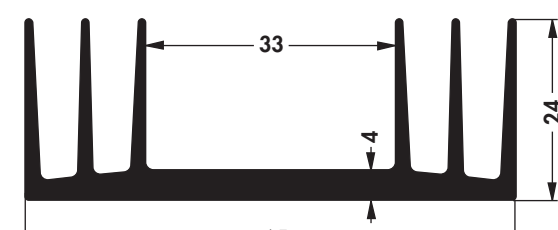
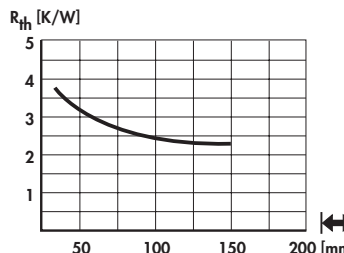
art. no.		
-----------------	--	---

SK 18 ...







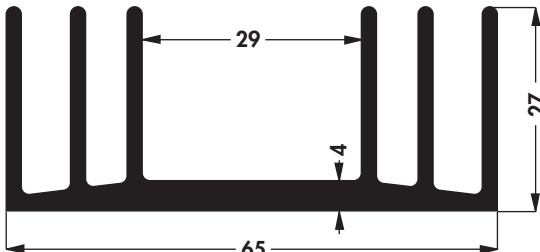
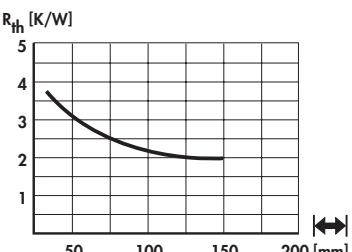

please indicate:

... $\left[\right]$
37.5 50 75 1000 mm

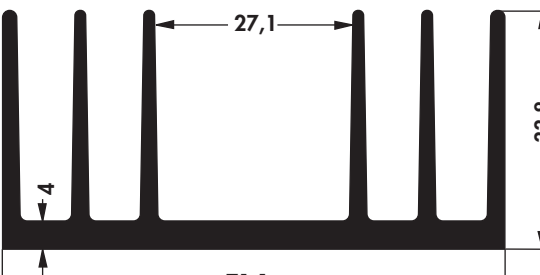
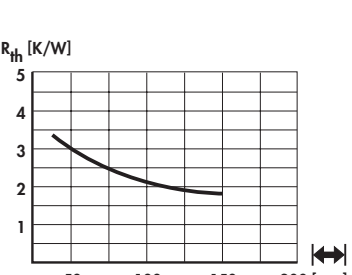
... \diamond (optional)
TO 3; CB

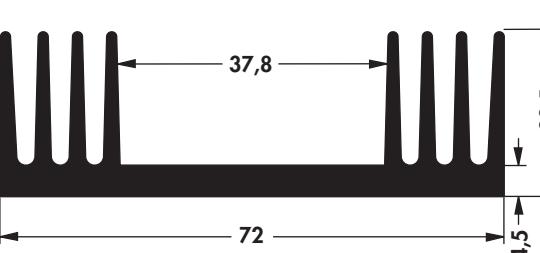
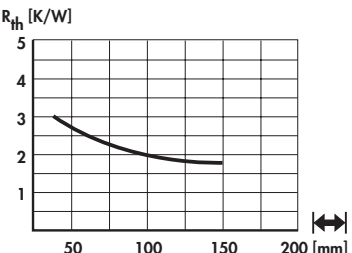
... custom processing (optional)
CNC = individual CNC machining
WL = desired length

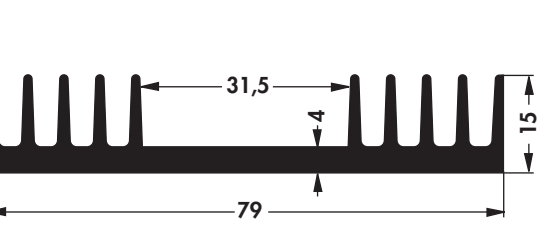
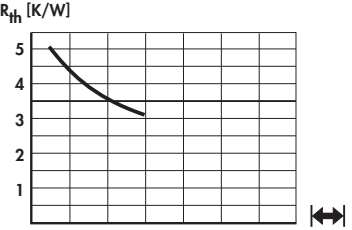
Standard extruded heatsinks

<p>art. no.</p> <p>SK 63 ...</p>		
<p>please indicate: ...  37.5 50 75 100 1000 mm ... ϕ (optional) TO 3; CB ... custom processing (optional) CNC = individual CNC machining WL = desired length</p>		
<p>art. no.</p> <p>SK 402 ...</p>		
<p>please indicate: ...  100 mm ... ϕ (optional) TO 3; CB ... custom processing (optional) CNC = individual CNC machining WL = desired length</p>		
<p>art. no.</p> <p>SK 97 ...</p>		
<p>please indicate: ...  37.5 50 75 100 1000 mm ... ϕ (optional) TO 3 ... custom processing (optional) CNC = individual CNC machining WL = desired length</p>		
<p>art. no.</p> <p>SK 45 ...</p>		
<p>please indicate: ...  37.5 50 75 100 1000 mm ... ϕ (optional) TO 3; CB ... custom processing (optional) CNC = individual CNC machining WL = desired length</p>		

B

C

D

E

F

G

H

I







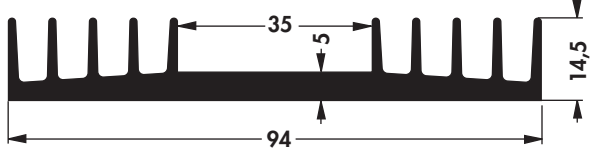
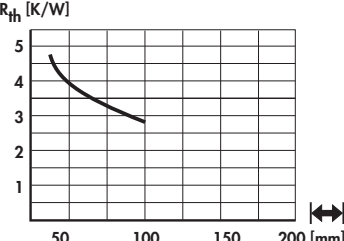

K

L

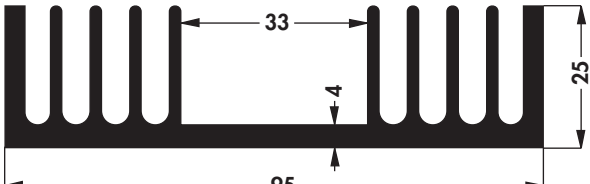
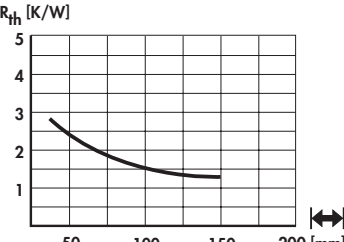
M

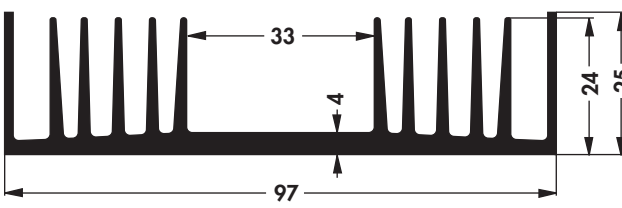
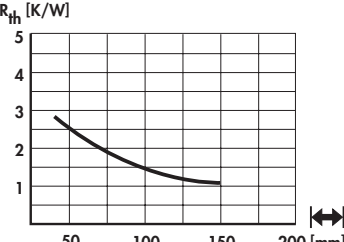
N

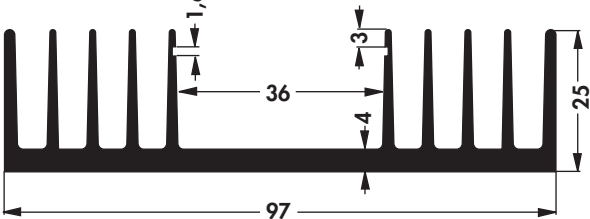
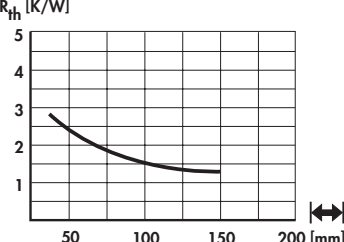
Standard extruded heatsinks

art. no. SK 19 ...		
<p>please indicate: ...  37.5 50 75 100 1000 mm ... ϕ (optional) TO 3; CB</p> <p>... custom processing (optional) CNC = individual CNC machining WL = desired length</p>		
art. no. SK 401 ...		
<p>please indicate: ...  100 1000 mm ... ϕ (optional) TO 3; CB</p> <p>... custom processing (optional) CNC = individual CNC machining WL = desired length</p>		
art. no. SK 72 ...		
<p>please indicate: ...  37.5 50 75 100 1000 mm ... ϕ (optional) TO 3; CB</p> <p>... custom processing (optional) CNC = individual CNC machining WL = desired length</p>		
art. no. SK 04 ...		
<p>with slots for cover plates or PCBs</p> <p>please indicate: ...  37.5 50 75 100 1000 mm ... ϕ (optional) SSR 1; SSR 2; TO 3; CB</p> <p>... custom processing (optional) CNC = individual CNC machining WL = desired length</p>		

Standard extruded heatsinks

<p>art. no.</p> <p>SK 403 ...</p>		
<p>please indicate: ... \longleftrightarrow 1000 mm ... custom processing (optional) CNC = individual CNC machining WL = desired length</p>		
<p>art. no.</p> <p>SK 73 ...</p>		
<p>please indicate: ... \longleftrightarrow 50 75 1000 mm ... Φ (optional) TO 3; CB ... custom processing (optional) CNC = individual CNC machining WL = desired length</p>		
<p>art. no.</p> <p>SK 71 ...</p>		
<p>please indicate: ... \longleftrightarrow 37.5 50 75 100 1000 mm ... Φ (optional) TO 3 ... custom processing (optional) CNC = individual CNC machining WL = desired length</p>		
<p>art. no.</p> <p>SK 57 ...</p>		
<p>SK 57 ... with slots for cover plates or PCBs</p> <p>please indicate: ... \longleftrightarrow 37.5 75 100 1000 mm ... custom processing (optional) CNC = individual CNC machining WL = desired length</p>		

B

C

D

E

F

G

H

I

K

L

M

N

Standard extruded heatsinks

B

C

D

E

F

G

H

I

K

L

M

N

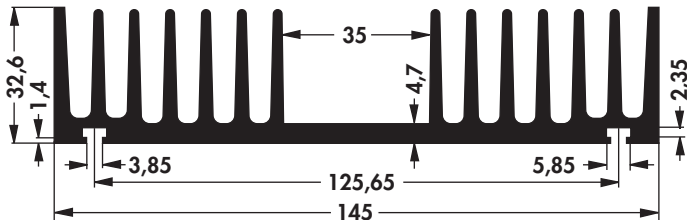
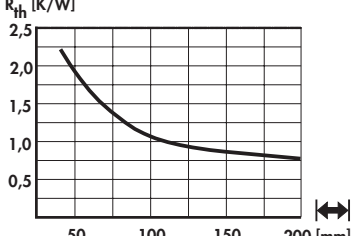
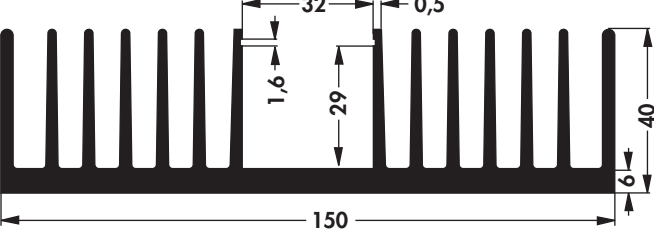
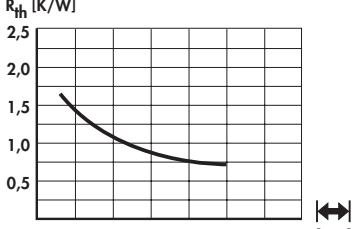
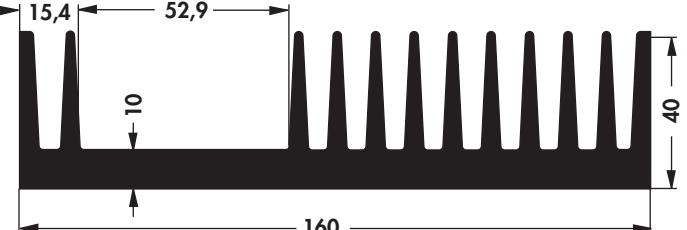
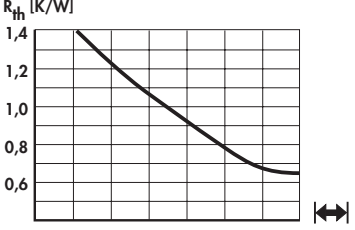
art. no. SK 197 ...		
<p>please indicate: ... $\left[\begin{array}{c} \text{---} \\ \text{---} \end{array} \right]$ 37.5 1000 mm ... ϕ (optional) TO 3; CB</p> <p>... custom processing (optional) CNC = individual CNC machining WL = desired length</p>		
art. no. SK 98 ...		
<p>with slots for cover plates or PCBs</p> <p>please indicate: ... $\left[\begin{array}{c} \text{---} \\ \text{---} \end{array} \right]$ 100 150 mm ... custom processing (optional) CNC = individual CNC machining WL = desired length</p>		
art. no. SK 404 ...		
<p>please indicate: ... $\left[\begin{array}{c} \text{---} \\ \text{---} \end{array} \right]$ 50 75 1000 mm ... ϕ (optional) TO 3; CB</p> <p>... custom processing (optional) CNC = individual CNC machining WL = desired length</p>		

Standard extruded heatsinks

<p>art. no.</p> <p>SK 36 ...</p>		
<p>mounting parts IS 1, IS 2, IS 3 → E 116</p>		
<p>please indicate: ... $\left[\right]$ 50 75 1000 mm ... \diamond (optional) TO 3; CB</p> <p>... custom processing (optional) CNC = individual CNC machining WL = desired length</p>		
<p>art. no.</p> <p>SK 01 ...</p>		
<p>mounting parts IS 1, IS 2, IS 3 → E 116</p>		
<p>please indicate: ... $\left[\right]$ 37.5 50 75 100 1000 mm ... \diamond (optional) TO 3; CB</p> <p>... custom processing (optional) CNC = individual CNC machining WL = desired length</p>		
<p>art. no.</p> <p>SK 02 ...</p>		
<p>with slots for cover plates or PCBs; mounting parts IS 1, IS 2, IS 3 → E 116</p>		
<p>please indicate: ... $\left[\right]$ 37.5 50 75 100 1000 mm ... \diamond (optional) TO 3; CB</p> <p>... custom processing (optional) CNC = individual CNC machining WL = desired length</p>		

B

C

D

E

F

G

H

I

K

L

M

N

Standard extruded heatsinks

B

C

D

E

F

G

H







I

K

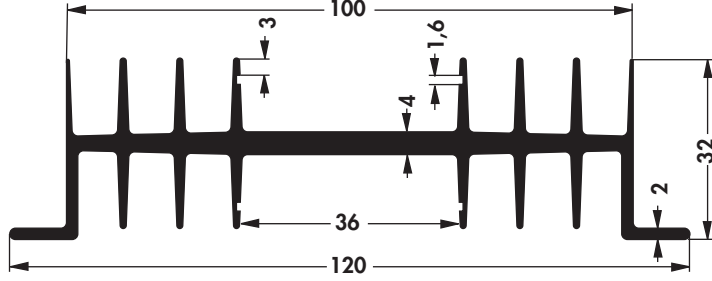
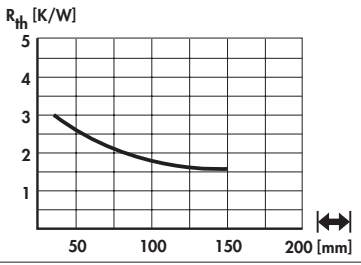

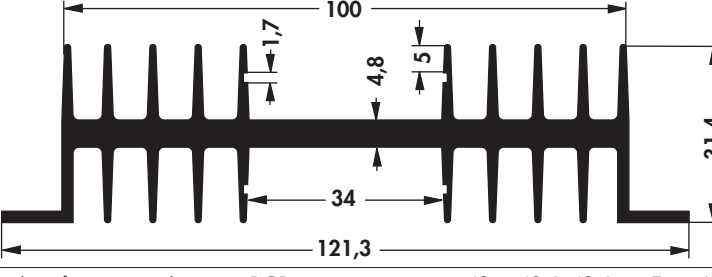
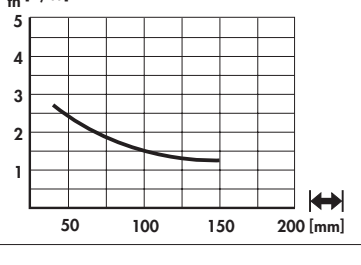
L

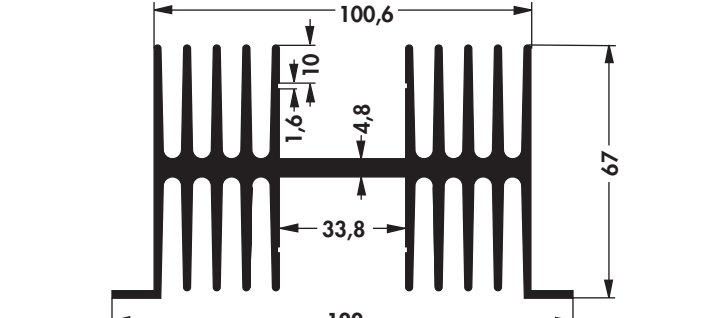
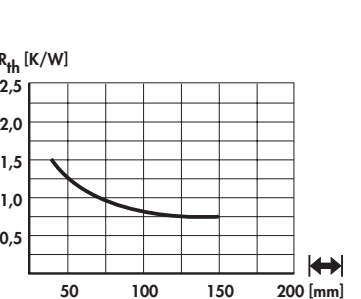
M

N

art. no. SK 03 ...		
with slots for cover plates or PCBs; mounting parts IS 1, IS 2, IS 3 → E 116		
please indicate: ...  50 75 100 1000 mm ...  (optional) TO 3; CB ... custom processing (optional) CNC = individual CNC machining WL = desired length		
art. no. SK 39 ...		
with slots for cover plates or PCBs; mounting parts IS 1, IS 2, IS 3 → E 116		
please indicate: ...  75 100 1000 mm ...  (optional) TO 3; CB ... custom processing (optional) CNC = individual CNC machining WL = desired length		
art. no. SK 30 ...		
with slots for cover plates or PCBs; mounting parts IS 1, IS 2, IS 3 → E 116		
please indicate: ...  75 100 1000 mm ...  (optional) TO 3; CB ... custom processing (optional) CNC = individual CNC machining WL = desired length		

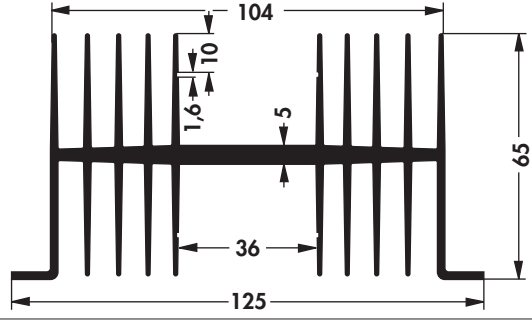
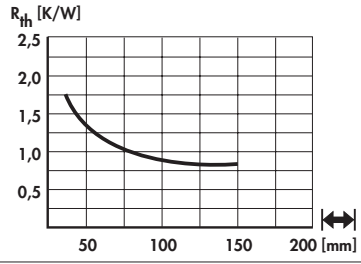
Standard extruded heatsinks

art. no.			
SK 34 ...	with slots for cover plates or PCBs; mounting parts IS 1, IS 2, IS 3 → E 116		
please indicate:	...  50 75 100 1000 mm	... ϕ (optional) TO 3; CB	
	... custom processing (optional) CNC = individual CNC machining WL = desired length		

B
C
D
E
F
G
H
I
K
L
M
N

Standard extruded heatsinks

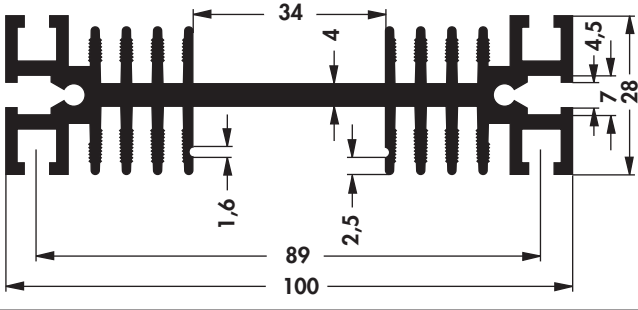
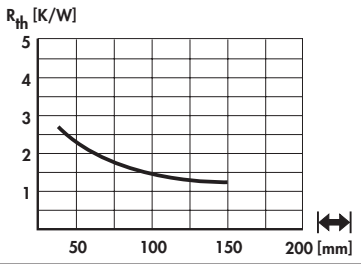
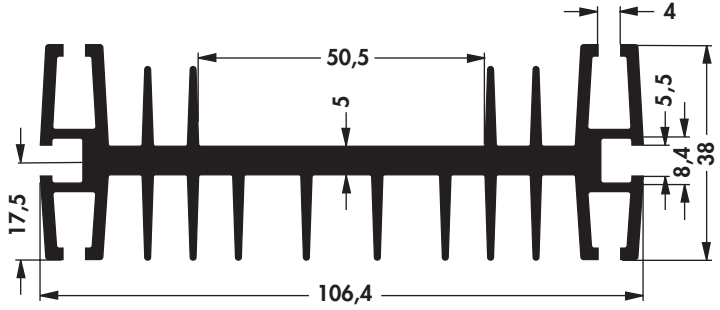
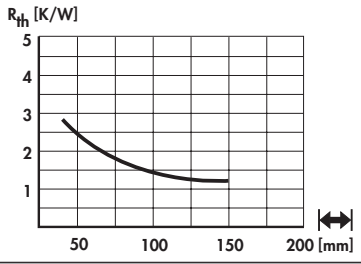
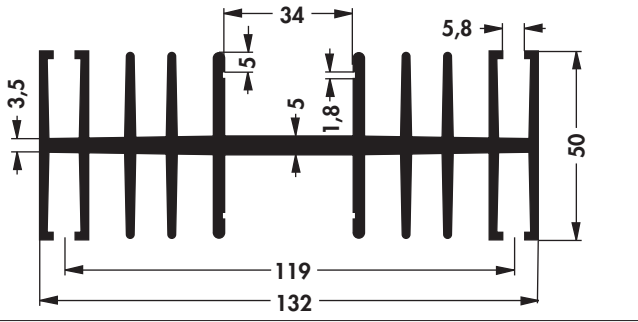
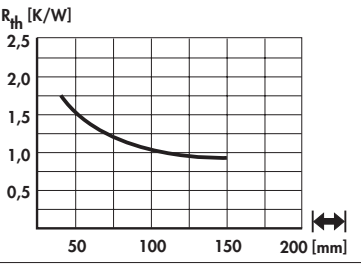
art. no. SK 20 ...		
with slots for cover plates or PCBs; mounting parts IS 5, IS 8 → E 116		
please indicate: <ul style="list-style-type: none"> ... 37.5 75 100 1000 mm ... custom processing (optional) CNC = individual CNC machining WL = desired length <ul style="list-style-type: none"> ... \varnothing (optional) TO 3; CB 		
art. no. SK 184 ...		
please indicate: <ul style="list-style-type: none"> ... 100 1000 mm ... custom processing (optional) CNC = individual CNC machining WL = desired length 		
art. no. SK 148 ...		
with slots for cover plates or PCBs		
please indicate: <ul style="list-style-type: none"> ... 37.5 100 1000 mm ... custom processing (optional) CNC = individual CNC machining WL = desired length <ul style="list-style-type: none"> ... \varnothing (optional) TO 3; CB 		

Standard extruded heatsinks

art. no.			
SK 67 ...	mounting part IS 6 → E 116		
please indicate:	...  37.5 50 100 1000 mm	... ϕ (optional) TO 3	
	... custom processing (optional) CNC = individual CNC machining WL = desired length		

B

C

D

E

F

G

H

I

K

L

M

N



Standard extruded heatsinks

<p>art. no.</p>	<p> \llcorner 37,5 mm 5,5 K/W \llcorner 75 mm 3,6 K/W </p>
<p>SK 65 ...</p>	<p>for cases SOT 32</p> <p>please indicate: ... \llcorner 37.5 75 mm ... ϕ (optional) 1xM3; 2xM3</p> <p>... custom processing (optional) CNC = individual CNC machining WL = desired length</p>
<p>art. no.</p>	<p> \llcorner 37,5 mm 4,1 K/W \llcorner 75 mm 2,7 K/W </p>
<p>SK 64 ...</p>	<p>for cases TO 220, TOP 3</p> <p>please indicate: ... \llcorner 37.5 75 mm ... ϕ (optional) 1xM3; 2xM3</p> <p>... custom processing (optional) CNC = individual CNC machining WL = desired length</p>
<p>art. no.</p>	<p> \llcorner 1000 mm </p>
<p>SK 419 ...</p>	<p>please indicate: ... \llcorner 1000 mm ... custom processing (optional) CNC = individual CNC machining WL = desired length</p>



Standard extruded heatsinks

<p>art. no.</p>		
<p>SK 69 ...</p>	<p>mounting parts IS 1, IS 2, IS 3 → E 116</p>	
<p>please indicate:</p>	<p>... $\overline{\hspace{1cm}}$ 50 75 100 1000 mm ... \diamond (optional) TO 3; CB</p> <p>... custom processing (optional) CNC = individual CNC machining WL = desired length</p>	
<p>art. no.</p>		
<p>SK 74 ...</p>	<p>... $\overline{\hspace{1cm}}$ 37.5 100 1000 mm ... \diamond (optional) TO 3; CB</p> <p>... custom processing (optional) CNC = individual CNC machining WL = desired length</p>	
<p>art. no.</p>		
<p>SK 124 ...</p>	<p>... $\overline{\hspace{1cm}}$ 50 100 150 1000 mm ... \diamond (optional) TO 3</p> <p>... custom processing (optional) CNC = individual CNC machining WL = desired length</p>	
<p>art. no.</p>		
<p>SK 195 ...</p>	<p>... $\overline{\hspace{1cm}}$ 75 100 mm ... \diamond (optional) TO 3; CB</p> <p>... custom processing (optional) CNC = individual CNC machining WL = desired length</p>	

B

C

D

E

F

G

H

I

K

L

M

N

Standard extruded heatsinks

B

C

D

E

F

G

H

I

K

L

M

N

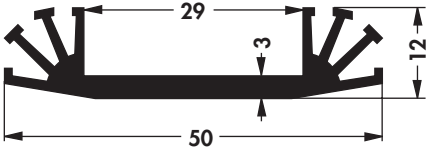
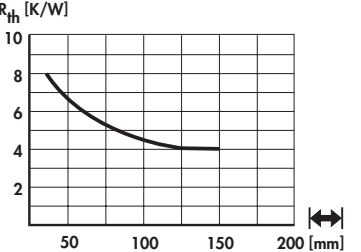
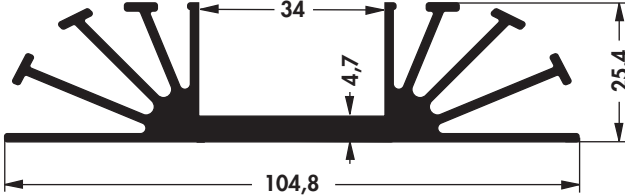
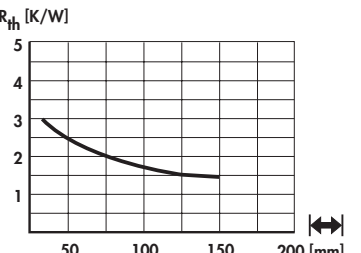
art. no. SK 31 ...		
<p>please indicate:</p> <p>... $\left[\right]$ 37.5 50 75 1000 mm</p> <p>... ϕ (optional) TO 3; CB</p> <p>... custom processing (optional) CNC = individual CNC machining WL = desired length</p>		
art. no. SK 16 ...		
<p>mountingpart IS 3 \rightarrow E 116</p> <p>please indicate:</p> <p>... $\left[\right]$ 75 1000 mm</p> <p>... ϕ (optional) TO 3; CB</p> <p>... custom processing (optional) CNC = individual CNC machining WL = desired length</p>		

Standard extruded heatsinks

<p>art. no.</p>		
<p>SK 185 ... extruded heatsink for PCB mounting → A 144</p> <p>please indicate: ... $\overleftrightarrow{\hspace{1cm}}$ 37.5 50 1000 mm ... \diamond (optional) TO 3; CB</p> <p>... custom processing (optional) CNC = individual CNC machining WL = desired length</p>		
<p>art. no.</p>		
<p>SK 48 ...</p> <p>please indicate: ... $\overleftrightarrow{\hspace{1cm}}$ 37.5 50 75 100 1000 mm ... \diamond (optional) SSR 3; TO 3; CB</p> <p>... custom processing (optional) CNC = individual CNC machining WL = desired length</p>		
<p>art. no.</p>		
<p>SK 79 ... with slots for cover plates or PCBs</p> <p>please indicate: ... $\overleftrightarrow{\hspace{1cm}}$ 37.5 50 75 100 1000 mm ... \diamond (optional) TO 3; CB</p> <p>... custom processing (optional) CNC = individual CNC machining WL = desired length</p>		
<p>art. no.</p>		
<p>SK 08 ... with slots for cover plates or PCBs</p> <p>please indicate: ... $\overleftrightarrow{\hspace{1cm}}$ 37.5 50 75 100 1000 mm ... \diamond (optional) TO 3; CB</p> <p>... custom processing (optional) CNC = individual CNC machining WL = desired length</p>		

B

C

D

E

F

G

H

I

K

L

M

N

Standard extruded heatsinks

B

C

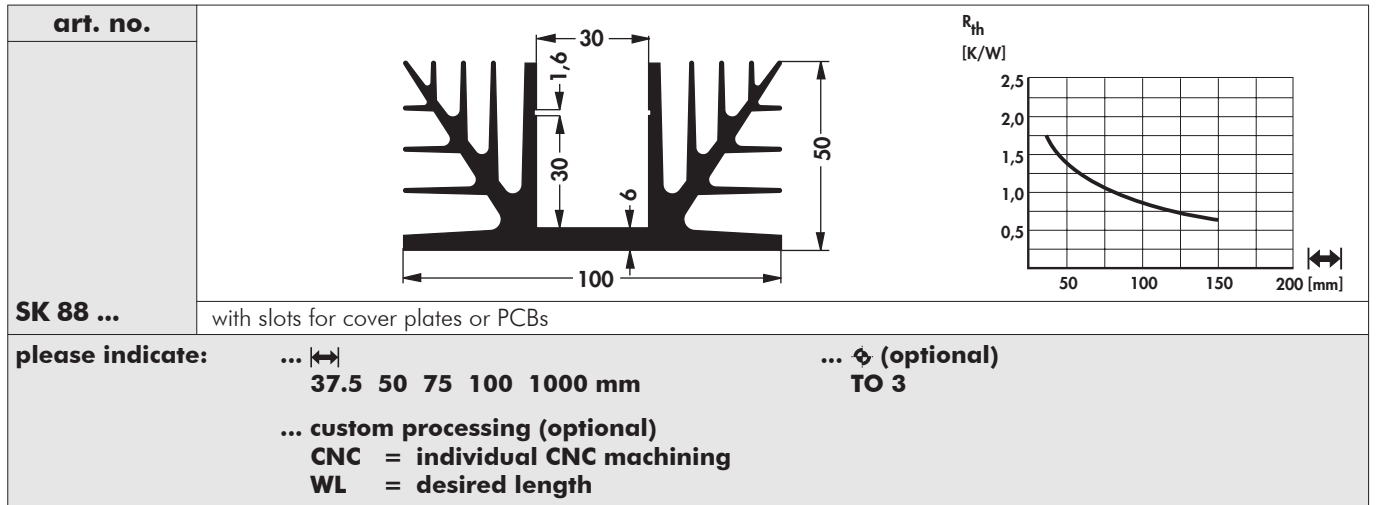

D

E

F

G

H

I

K

L

M

N

Standard extruded heatsinks

<p>art. no.</p> <p>SK 52 ...</p>		
<p>please indicate: ... $\overline{\text{mm}}$ 37.5 50 75 100 1000 mm ... \diamond (optional) 2xTO 3; 2xCB</p> <p>... custom processing (optional) CNC = individual CNC machining WL = desired length</p>		
<p>art. no.</p> <p>SK 60 ...</p>		
<p>please indicate: ... $\overline{\text{mm}}$ 50 75 100 1000 mm ... \diamond (optional) 2xTO 3; 2xCB</p> <p>... custom processing (optional) CNC = individual CNC machining WL = desired length</p>		
<p>art. no.</p> <p>SK 147 ...</p>		
<p>please indicate: ... $\overline{\text{mm}}$ 50 150 1000 mm ... \diamond (optional) 2xTO 3; 2xCB</p> <p>... custom processing (optional) CNC = individual CNC machining WL = desired length</p>		
<p>art. no.</p> <p>SK 80 ...</p>		
<p>please indicate: ... $\overline{\text{mm}}$ 75 100 1000 mm ... \diamond (optional) 2xTO 3; 2xCB</p> <p>... custom processing (optional) CNC = individual CNC machining WL = desired length</p>		

B

C

D

E

F

G

H

I

K

L

M

N

Standard extruded heatsinks

B

C

D

E

F

G

H







I

K

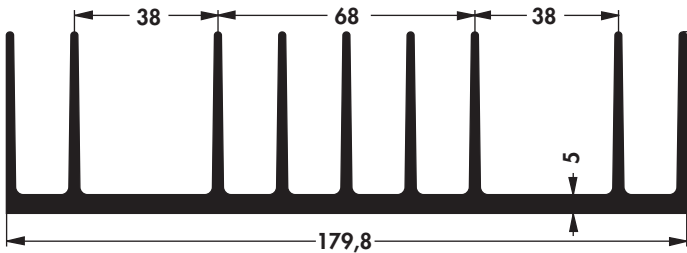
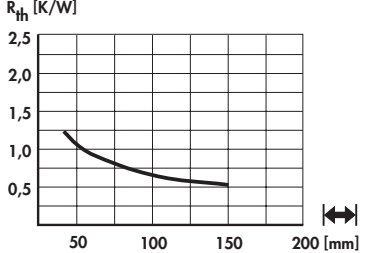
L

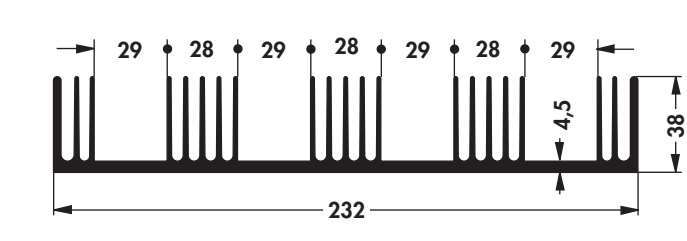
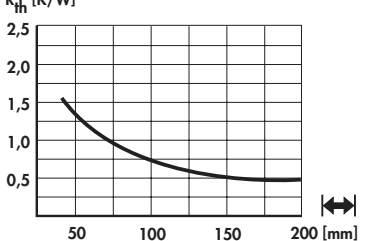
M

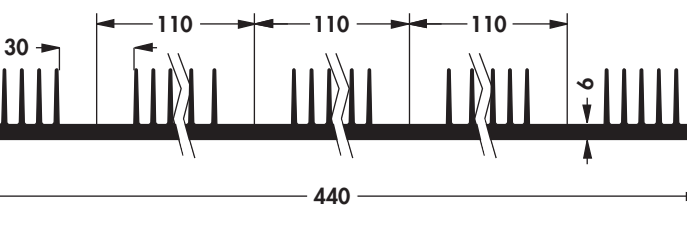
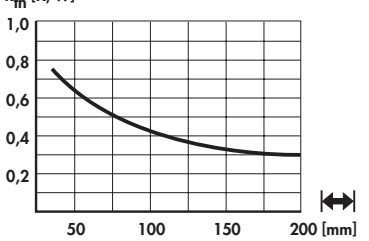
N

art. no. SK 53 ...		
<p>please indicate: ...  50 75 100 150 1000 mm ...  (optional) 2xTO 3; 2xCB</p> <p>... custom processing (optional) CNC = individual CNC machining WL = desired length</p>		
art. no. SK 86 ...		
<p>please indicate: ...  100 150 1000 mm ... custom processing (optional) CNC = individual CNC machining WL = desired length</p>		
art. no. SK 82 ...		
<p>please indicate: ...  100 1000 mm ... custom processing (optional) CNC = individual CNC machining WL = desired length</p>		

Standard extruded heatsinks

<p>art. no.</p> <p>SK 596 ...</p>		
<p>please indicate: ... $\left[\begin{array}{c} \text{---} \\ \text{---} \\ \text{---} \end{array} \right]$ 37.5 50 75 100 1000 mm</p> <p>... custom processing (optional) CNC = individual CNC machining WL = desired length</p>		
<p>art. no.</p> <p>SK 544 ...</p>		
<p>please indicate: ... $\left[\begin{array}{c} \text{---} \\ \text{---} \\ \text{---} \end{array} \right]$ 50 75 100 1000 mm</p> <p>... custom processing (optional) CNC = individual CNC machining WL = desired length</p>		
<p>art. no.</p> <p>SK 32 ...</p>		
<p>please indicate: ... $\left[\begin{array}{c} \text{---} \\ \text{---} \\ \text{---} \end{array} \right]$ 37.5 50 75 100 1000 mm</p> <p>... custom processing (optional) CNC = individual CNC machining WL = desired length</p>		
<p>art. no.</p> <p>SK 187 ...</p>		
<p>please indicate: ... $\left[\begin{array}{c} \text{---} \\ \text{---} \\ \text{---} \end{array} \right]$ 75 1000 mm</p> <p>... custom processing (optional) CNC = individual CNC machining WL = desired length</p>		

B

C

D

E

F

G

H

I







K

L

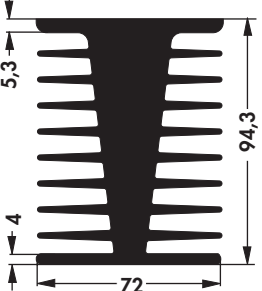
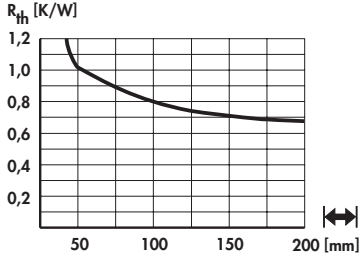
M

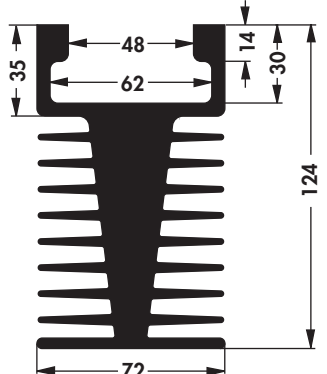
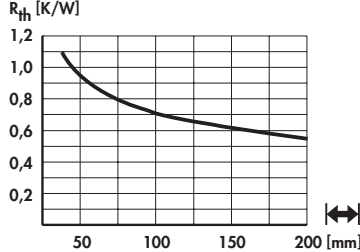
N

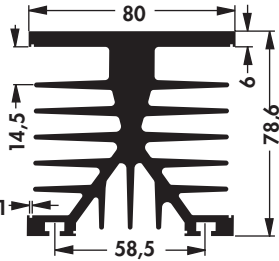
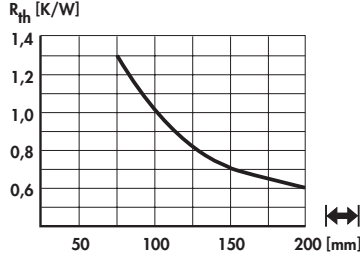
Standard extruded heatsinks

art. no. SK 556 ...	 <p>Dimensions: 5,3, 94,3, 4, 72</p>	 <p>R_{th} [K/W]</p> <p>50 100 150 200 [mm]</p>
please indicate: ...  75 100 150 1000 mm		... custom processing (optional) CNC = individual CNC machining WL = desired length
art. no. SK 15 ...	 <p>Dimensions: 48, 14, 30, 35, 62, 124, 72</p>	 <p>R_{th} [K/W]</p> <p>50 100 150 200 [mm]</p>
please indicate: ...  75 1000 mm		... custom processing (optional) CNC = individual CNC machining WL = desired length
art. no. SK 89 ...	 <p>Dimensions: 80, 6, 78,6, 14,5, 58,5, 1</p>	 <p>R_{th} [K/W]</p> <p>50 100 150 200 [mm]</p>
SK 89 ... with slots for cover plates or PCBs		
please indicate: ...  100 150 1000 mm ... custom processing (optional) CNC = individual CNC machining WL = desired length		... Φ (optional) SSR 1; SSR 2

Standard extruded heatsinks

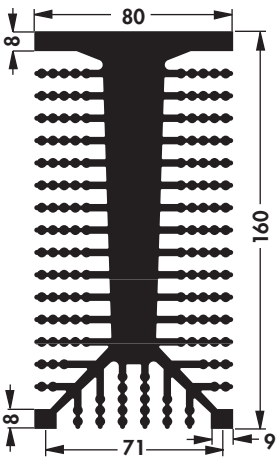
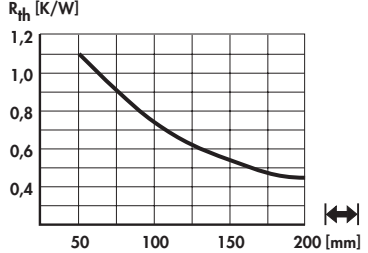
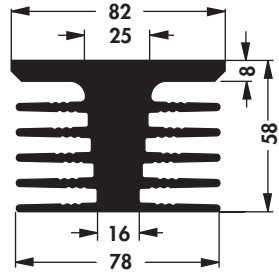
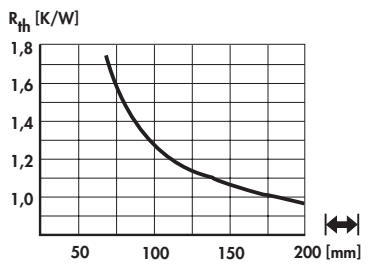
<p>art. no.</p> <p>SK 163 ...</p>		
<p>please indicate: ... $\left[\right]$ 100 150 1000 mm</p> <p>... custom processing (optional) CNC = individual CNC machining WL = desired length</p>		
<p>art. no.</p> <p>SK 176 ...</p>		
<p>please indicate: ... $\left[\right]$ 75 100 150 1000 mm</p> <p>... custom processing (optional) CNC = individual CNC machining WL = desired length</p> <p>... \diamond (optional) SSR 2</p>		

B

C

D

E

F

G

H

I

K

L

M

N

Standard extruded heatsinks

art. no. SK 83 ...		
<p>please indicate: ... $\left[\begin{array}{ c } \hline \text{---} \\ \hline \end{array} \right]$ 100 1000 mm</p> <p>... custom processing (optional) CNC = individual CNC machining WL = desired length</p>		
art. no. SK 06 ...	<p>mounting part IS 4 → E 116</p>	
<p>please indicate: ... $\left[\begin{array}{ c } \hline \text{---} \\ \hline \end{array} \right]$ 75 1000 mm</p> <p>... custom processing (optional) CNC = individual CNC machining WL = desired length</p>		
art. no. SK 23 ...	<p>with slots for cover plates or PCBs; equipped with fan and endplates = LA 4 → D 21</p>	
<p>please indicate: ... $\left[\begin{array}{ c } \hline \text{---} \\ \hline \end{array} \right]$ 75 mm</p> <p>... custom processing (optional) CNC = individual CNC machining WL = desired length</p>		







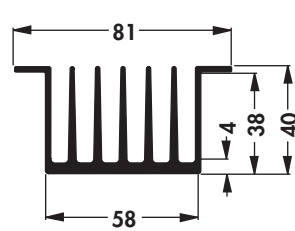
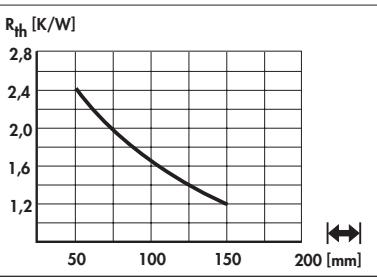

Standard extruded heatsinks

<p>art. no.</p> <p>SK 110 ...</p>		
<p>please indicate: ... 150 200 1000 mm</p>		<p>... custom processing (optional) CNC = individual CNC machining WL = desired length</p>
<p>art. no.</p> <p>SK 109 ...</p>		
<p>with slots for cover plates or PCBs</p> <p>please indicate: ... 100 150 200 1000 mm</p>		<p>... custom processing (optional) CNC = individual CNC machining WL = desired length</p>

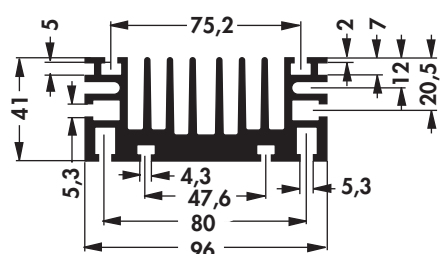
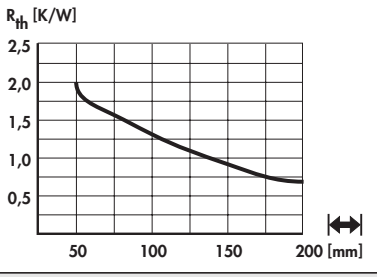
- B
- C
- D
- E
- F
- G
- H
- I
- K
- L
- M
- N

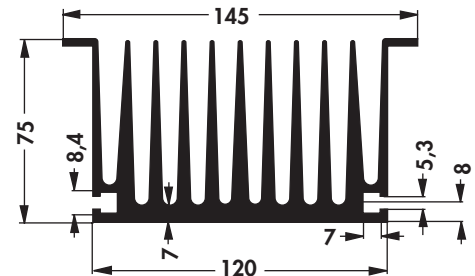
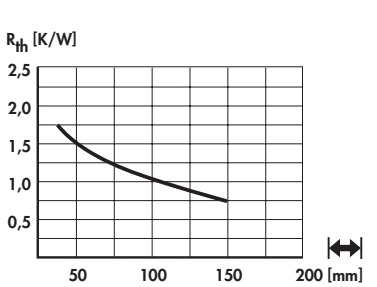

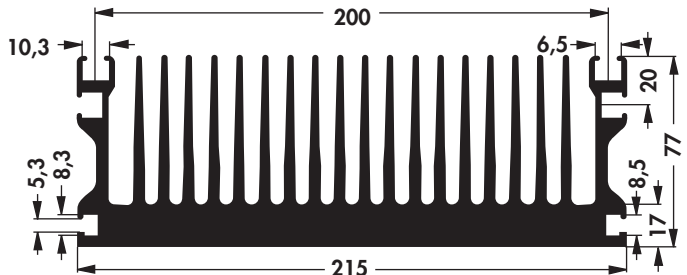
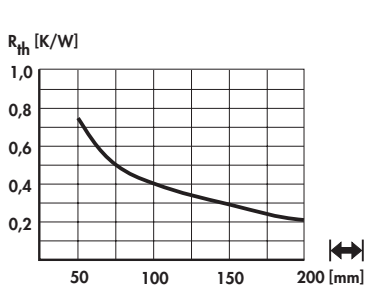
Standard extruded heatsinks

art. no. SK 111 ...		
<p>please indicate: ...  75 100 1000 mm ...  (optional) SSR 1; SSR 3</p> <p>... custom processing (optional) CNC = individual CNC machining WL = desired length</p>		
art. no. SK 172 ...		
<p>please indicate: ...  50 75 100 150 1000 mm ... custom processing (optional) CNC = individual CNC machining WL = desired length</p>		
art. no. SK 194 ...		
<p>please indicate: ...  75 1000 mm ... custom processing (optional) CNC = individual CNC machining WL = desired length</p>		
art. no. SK 435 ...		
<p>please indicate: ...  150 200 1000 mm ... custom processing (optional) CNC = individual CNC machining WL = desired length</p>		

Standard extruded heatsinks

<p>art. no.</p>		
<p>SK 432 ... with slots for cover plates or PCBs</p>		
<p>please indicate: ... mm 100 1000 mm ... custom processing (optional) CNC = individual CNC machining WL = desired length</p>		
<p>art. no.</p>		
<p>SK 40 ... please indicate: ... mm 100 1000 mm ... custom processing (optional) CNC = individual CNC machining WL = desired length</p>		
<p>art. no.</p>		
<p>SK 61 ... with slots for cover plates or PCBs; → cooling case ... case catalogue f.case</p>		
<p>please indicate: ... mm 75 100 150 1000 mm ... custom processing (optional) CNC = individual CNC machining WL = desired length</p>		
<p>art. no.</p>		
<p>SK 144 ... please indicate: ... mm 1000 mm ... custom processing (optional) CNC = individual CNC machining WL = desired length</p>		

B
C
D
E
F
G
H
I
K
L
M
N

A

fischer elektronik

Standard extruded heatsinks

B

C

D

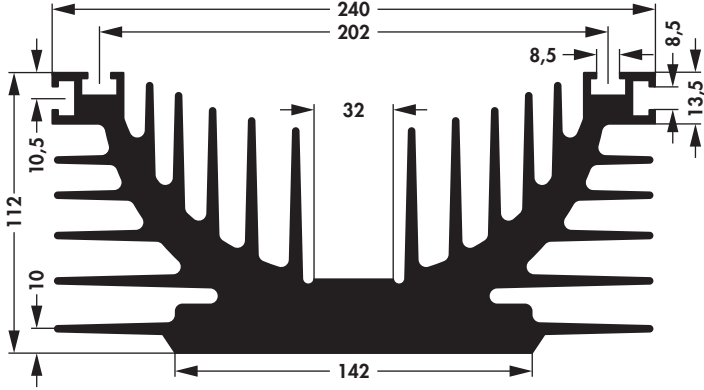
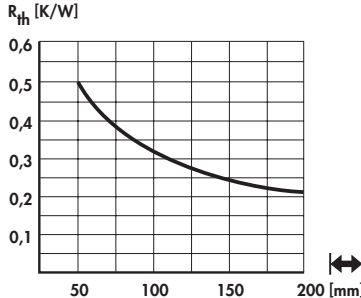
art. no. SK 698 ...		
<p>please indicate: ... $\left[\begin{array}{c} \text{---} \\ \text{---} \end{array} \right]$ 75 100 150 200 1000 mm</p> <p>... custom processing (optional) CNC = individual CNC machining WL = desired length</p>		

E

F

G

H

I

K

L

M







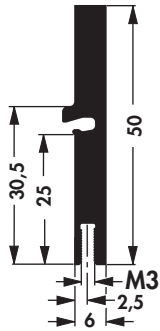
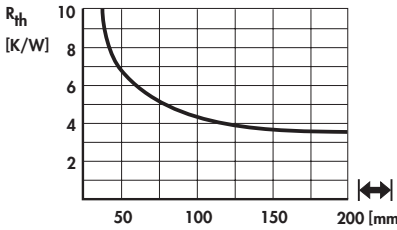

N

A 117

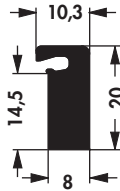
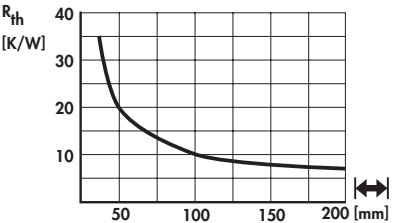
Technical introduction

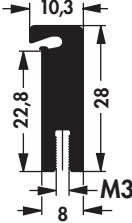
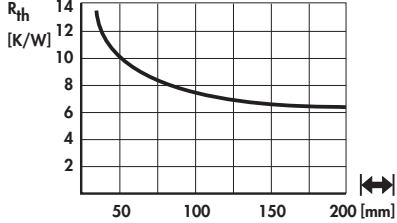

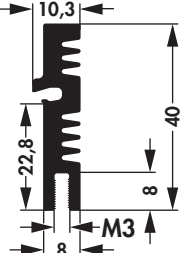
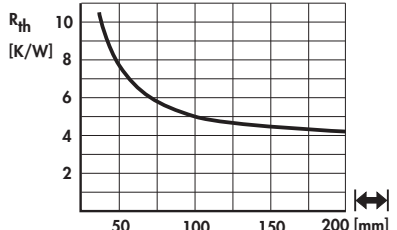



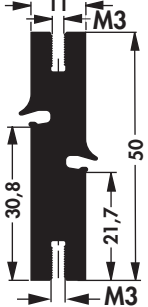
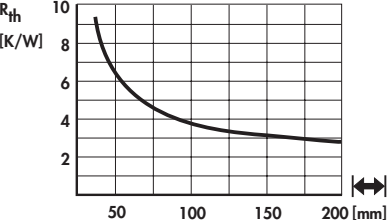

→ A 2 – 8

Extruded heatsinks for lock-in retaining spring

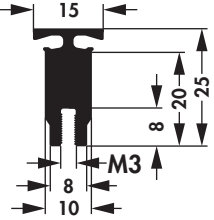
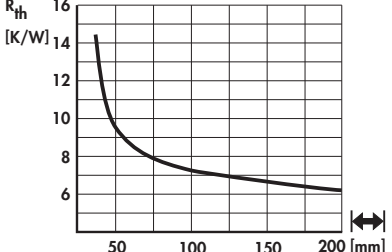
<p>art. no.</p> <p>SK 575 ...</p>			
<p>please indicate: ...  25 37.5 50 75 84 100 1000 mm</p>		<p>... custom processing (optional) CNC = individual CNC machining WL = desired length</p>	
<p>art. no.</p> <p>SK 512 ...</p>			
<p>please indicate: ...  25 50 100 1000 mm</p>		<p>... custom processing (optional) CNC = individual CNC machining WL = desired length</p>	
<p>art. no.</p> <p>SK 480 ...</p>			
<p>please indicate: ...  25 37.5 50 75 84 100 1000 mm</p>		<p>... custom processing (optional) CNC = individual CNC machining WL = desired length</p>	
<p>art. no.</p> <p>SK 638 ...</p>			
<p>please indicate: ...  25 37.5 50 75 84 100 1000 mm</p>		<p>... custom processing (optional) CNC = individual CNC machining WL = desired length</p>	

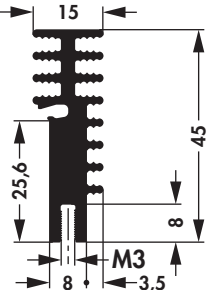
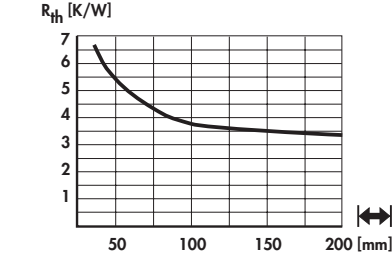

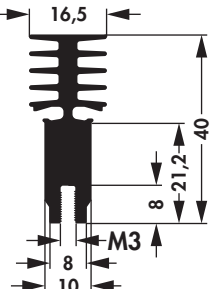
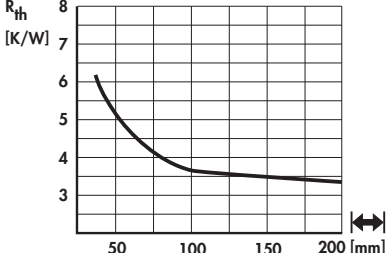

please note: profile threads → A 5; screw-in solder pin ELS 3 / ELS 3 B → A 127

Extruded heatsinks for lock-in retaining spring

art. no. SK 490 ...				
please indicate: ... 		37.5 50 75 84 100 1000 mm	... custom processing (optional) CNC = individual CNC machining WL = desired length	
art. no. SK 701 ...				
please indicate: ... 		25 37.5 50 75 84 100 1000 mm	... custom processing (optional) CNC = individual CNC machining WL = desired length	
art. no. SK 703 ...				
please indicate: ... 		25 37.5 50 75 84 100 1000 mm	... custom processing (optional) CNC = individual CNC machining WL = desired length	
art. no. SK 681 ...				
please indicate: ... 		25 37.5 50 75 84 100 1000 mm	... custom processing (optional) CNC = individual CNC machining WL = desired length	

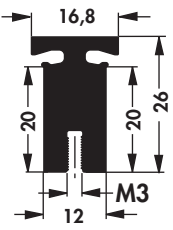
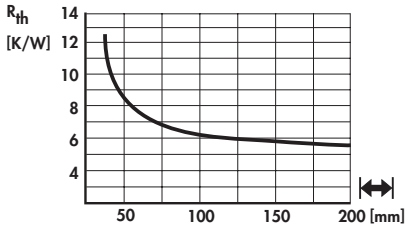
please note: profile threads → A 5; screw-in solder pin ELS 3 / ELS 3 B → A 127

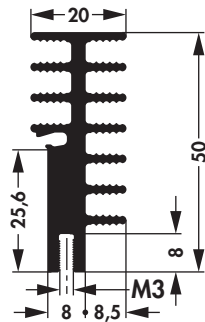
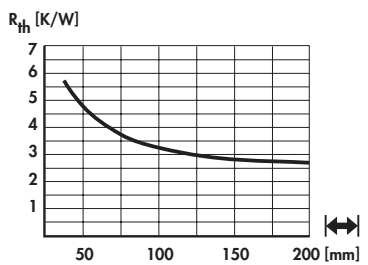
Extruded heatsinks for lock-in retaining spring

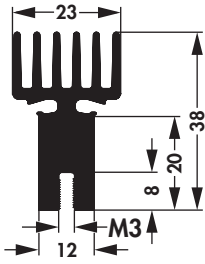
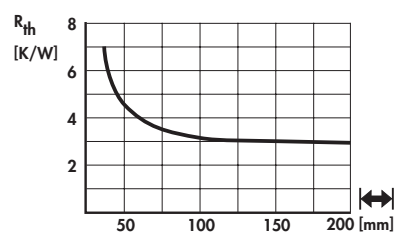
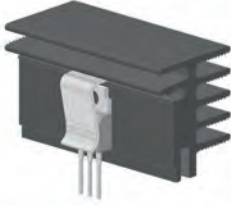
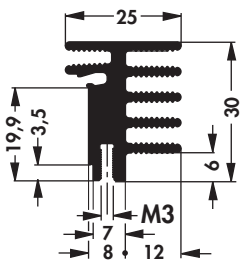
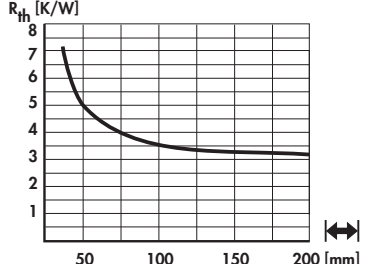
<p>art. no.</p> <p>SK 492 ...</p>			
<p>please indicate: ... $\left[\begin{array}{c} \text{---} \\ \text{---} \end{array} \right]$ 25 37.5 50 75 84 100 1000 mm ... custom processing (optional) CNC = individual CNC machining WL = desired length</p>			
<p>art. no.</p> <p>SK 702 ...</p>			
<p>please indicate: ... $\left[\begin{array}{c} \text{---} \\ \text{---} \end{array} \right]$ 25 37.5 50 75 84 100 1000 mm ... custom processing (optional) CNC = individual CNC machining WL = desired length</p>			
<p>art. no.</p> <p>SK 637 ...</p>			
<p>please indicate: ... $\left[\begin{array}{c} \text{---} \\ \text{---} \end{array} \right]$ 25 37.5 50 75 84 100 1000 mm ... custom processing (optional) CNC = individual CNC machining WL = desired length</p>			
<p>art. no.</p> <p>SK 573 ...</p>			
<p>please indicate: ... $\left[\begin{array}{c} \text{---} \\ \text{---} \end{array} \right]$ 25 37.5 50 75 84 100 1000 mm ... custom processing (optional) CNC = individual CNC machining WL = desired length</p>			

please note: profile threads → A 5; screw-in solder pin ELS 3 / ELS 3 B → A 127

B
C
D
E
F
G
H
I
K
L
M
N

A

Extruded heatsinks for lock-in retaining spring

B

C

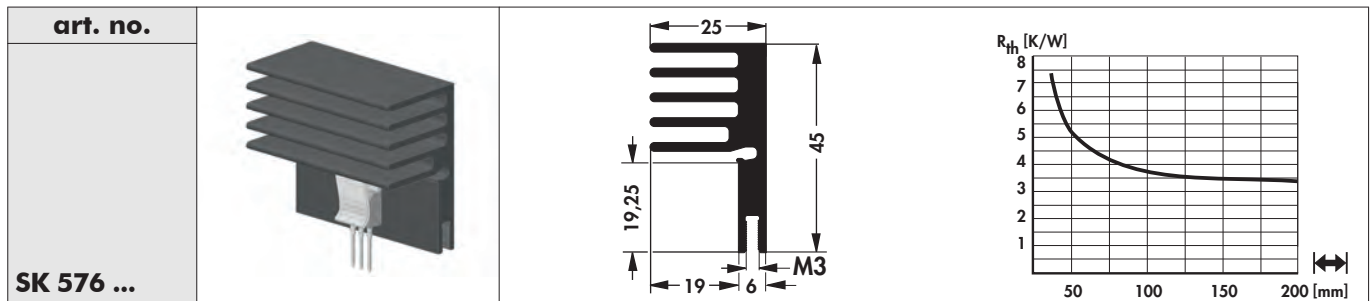

SK 576 ...

please indicate:

 ...  25 37.5 50 75 84 100 1000 mm

... custom processing (optional)

 CNC = individual CNC machining
 WL = desired length

D

E

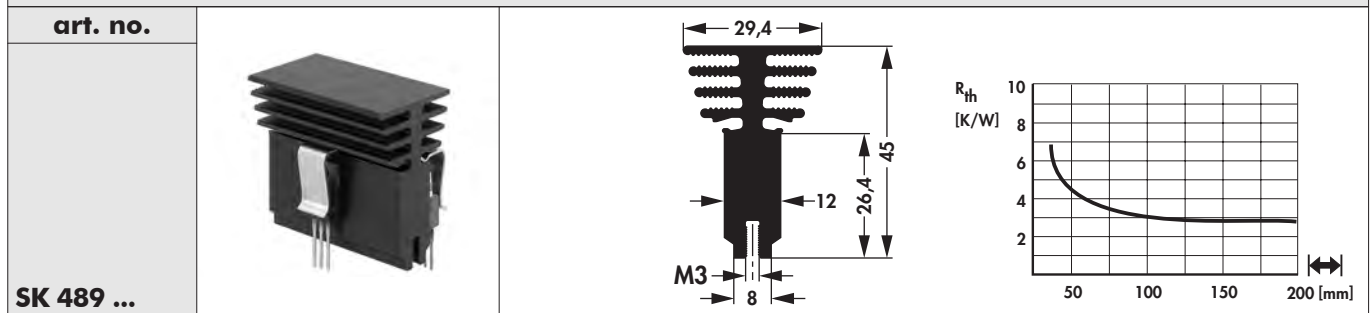

SK 489 ...

please indicate:

 ...  25 37.5 50 75 84 100 1000 mm

... custom processing (optional)

 CNC = individual CNC machining
 WL = desired length

F

G

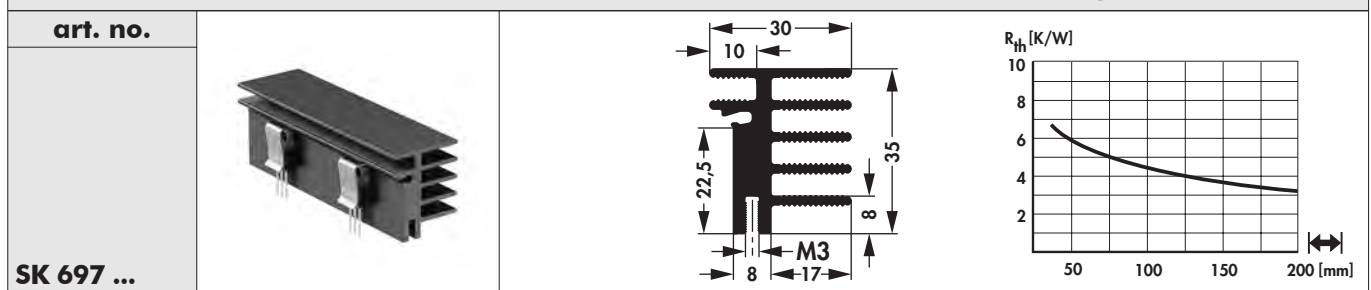

SK 697 ...

please indicate:

 ...  25 37.5 50 75 84 100 150 1000 mm

... custom processing (optional)

 CNC = individual CNC machining
 WL = desired length

H

I

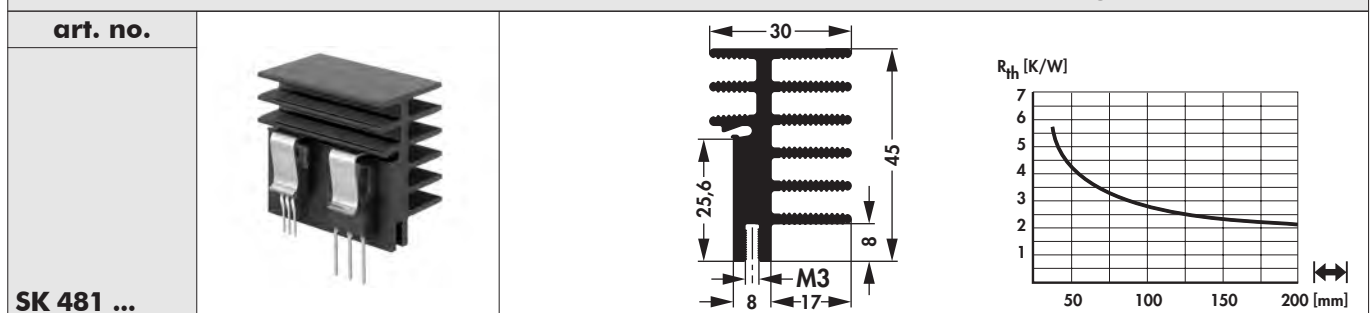

SK 481 ...

please indicate:

 ...  25 37.5 50 75 84 100 1000 mm

... custom processing (optional)

 CNC = individual CNC machining
 WL = desired length

K





L

please note: profile threads → A 5; screw-in solder pin ELS 3 / ELS 3 B → A 127

M

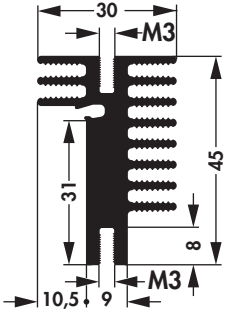
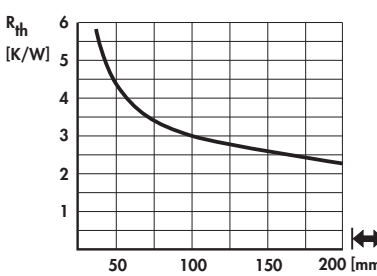
N

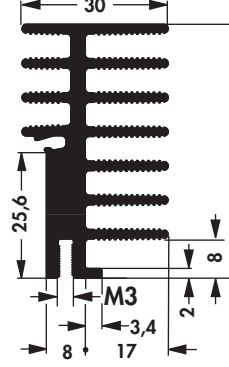
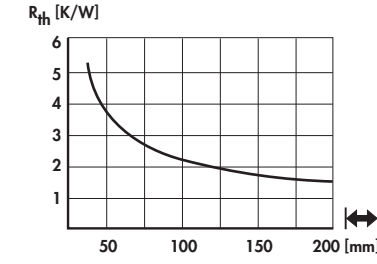
Extruded heatsinks for lock-in retaining spring

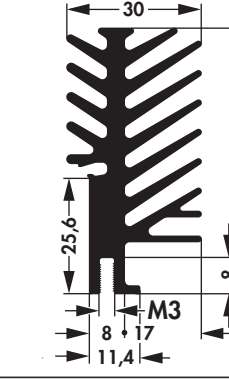
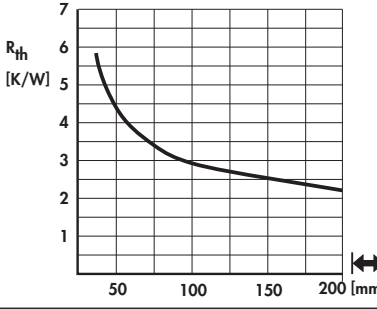
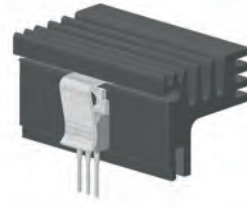
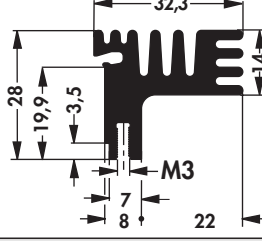
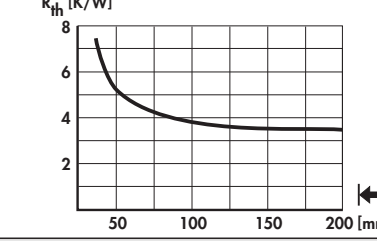
<p>art. no.</p> <p>SK 639 ...</p>			
<p>please indicate: ... $\left[\begin{array}{c} \text{---} \\ \text{---} \end{array} \right]$</p> <p>25 37.5 50 75 84 100 1000 mm</p>		<p>... custom processing (optional)</p> <p>CNC = individual CNC machining</p> <p>WL = desired length</p>	
<p>art. no.</p> <p>SK 514 ...</p>			
<p>please indicate: ... $\left[\begin{array}{c} \text{---} \\ \text{---} \end{array} \right]$</p> <p>25 37.5 50 75 100 1000 mm</p>		<p>... custom processing (optional)</p> <p>CNC = individual CNC machining</p> <p>WL = desired length</p>	
<p>art. no.</p> <p>SK 640 ...</p>			
<p>please indicate: ... $\left[\begin{array}{c} \text{---} \\ \text{---} \end{array} \right]$</p> <p>25 37.5 50 75 84 100 1000 mm</p>		<p>... custom processing (optional)</p> <p>CNC = individual CNC machining</p> <p>WL = desired length</p>	
<p>art. no.</p> <p>SK 574 ...</p>			
<p>please indicate: ... $\left[\begin{array}{c} \text{---} \\ \text{---} \end{array} \right]$</p> <p>25 37.5 50 75 84 100 1000 mm</p>		<p>... custom processing (optional)</p> <p>CNC = individual CNC machining</p> <p>WL = desired length</p>	

please note: profile threads → A 5; screw-in solder pin ELS 3 / ELS 3 B → A 127

Extruded heatsinks for lock-in retaining spring

B

C

D

E

F

G

H







I

K

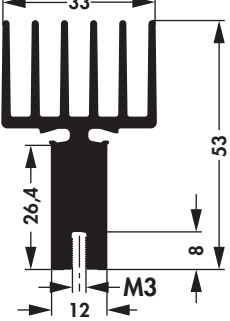
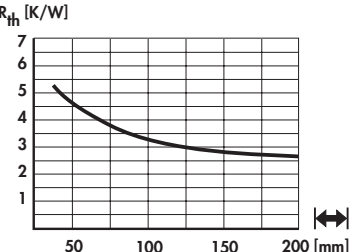
L

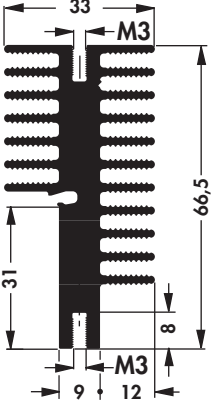
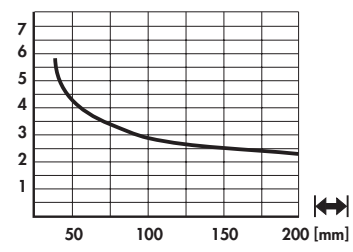

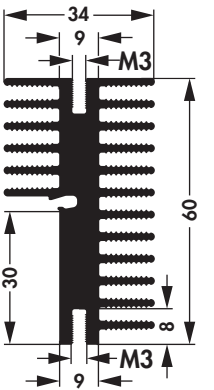
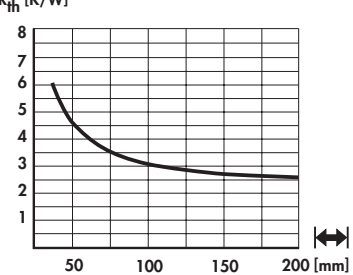



M

N

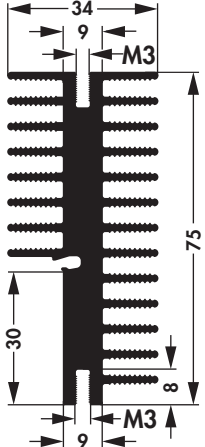
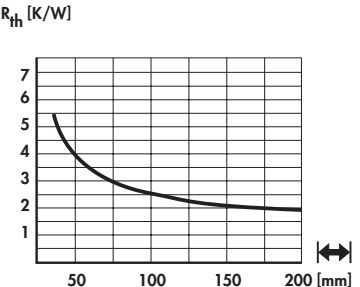
art. no. SK 704 ...			
please indicate: ...  25 37.5 50 75 84 100 1000 mm		... custom processing (optional) CNC = individual CNC machining WL = desired length	
art. no. SK 589 ...			
please indicate: ...  25 37.5 50 75 84 100 1000 mm		... custom processing (optional) CNC = individual CNC machining WL = desired length	
art. no. SK 669 ...			
please indicate: ...  25 37.5 50 75 84 100 1000 mm		... custom processing (optional) CNC = individual CNC machining WL = desired length	

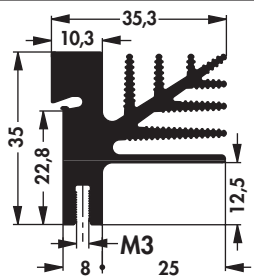
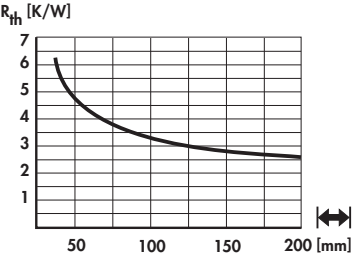
please note: profile threads → A 5; screw-in solder pin ELS 3 / ELS 3 B → A 127

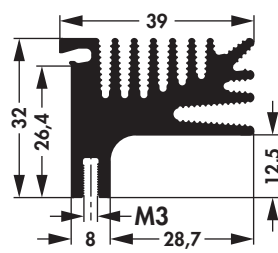
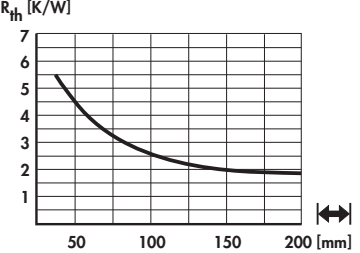
Extruded heatsinks for lock-in retaining spring

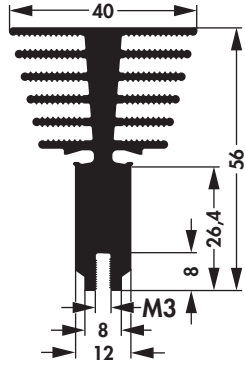
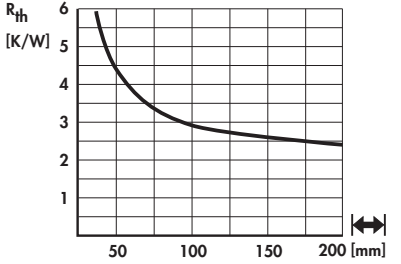
<p>art. no.</p> <p>SK 665 ...</p>			
<p>please indicate: ... $\left[\text{mm} \right]$ 25 37.5 50 75 84 100 1000 mm</p>		<p>... custom processing (optional) CNC = individual CNC machining WL = desired length</p>	
<p>art. no.</p> <p>SK 482 ...</p>			
<p>please indicate: ... $\left[\text{mm} \right]$ 25 37.5 50 75 84 100 1000 mm</p>		<p>... custom processing (optional) CNC = individual CNC machining WL = desired length</p>	
<p>art. no.</p> <p>SK 705 ...</p>			
<p>please indicate: ... $\left[\text{mm} \right]$ 25 37.5 50 75 84 100 1000 mm</p>		<p>... custom processing (optional) CNC = individual CNC machining WL = desired length</p>	
<p>art. no.</p> <p>SK 641 ...</p>			
<p>please indicate: ... $\left[\text{mm} \right]$ 25 37.5 50 75 84 100 1000 mm</p>		<p>... custom processing (optional) CNC = individual CNC machining WL = desired length</p>	

please note: profile threads → A 5; screw-in solder pin ELS 3 / ELS 3 B → A 127





A

Extruded heatsinks for lock-in retaining spring

B

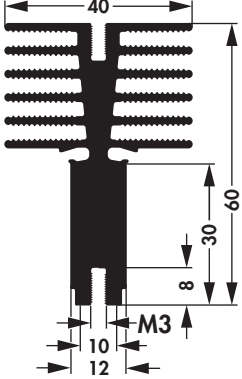
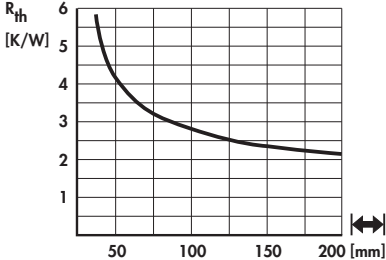
C

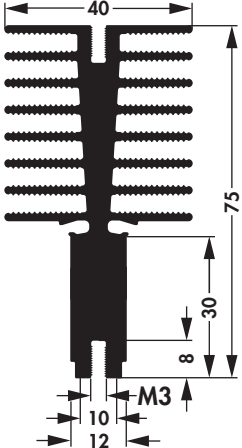
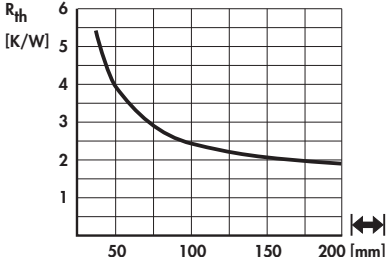
D

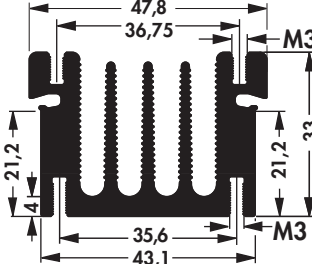
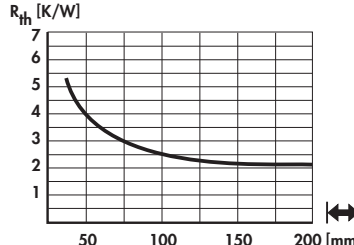
art. no. SK 664 ...			
please indicate: ... [mm] 25 37.5 50 75 84 100 1000 mm		... custom processing (optional) CNC = individual CNC machining WL = desired length	
art. no. SK 662 ...			
please indicate: ... [mm] 25 37.5 50 75 84 100 1000 mm		... custom processing (optional) CNC = individual CNC machining WL = desired length	
art. no. SK 495 ...			
please indicate: ... [mm] 25 37.5 50 75 100 1000 mm		... custom processing (optional) CNC = individual CNC machining WL = desired length	







please note: profile threads → A 5; screw-in solder pin ELS 3 / ELS 3 B → A 127

L

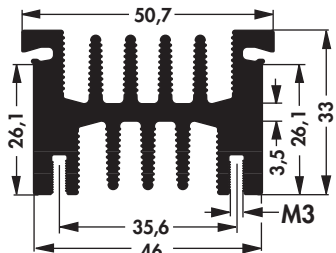
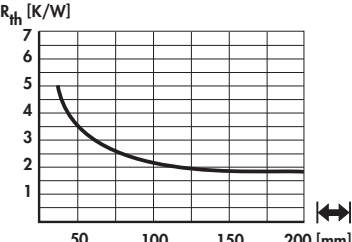
M

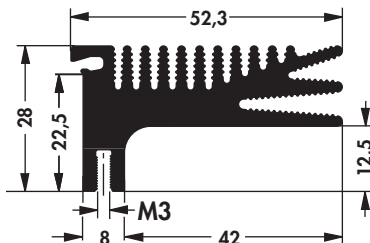
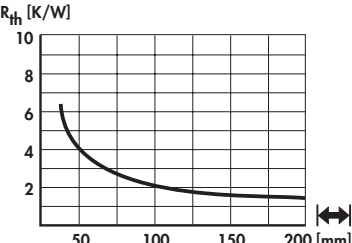
N

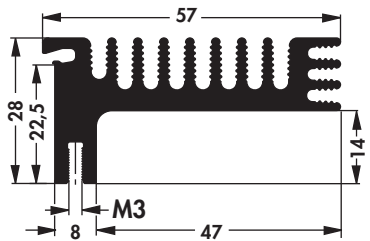
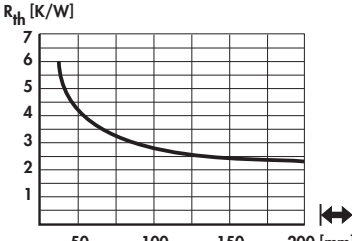
Extruded heatsinks for lock-in retaining spring

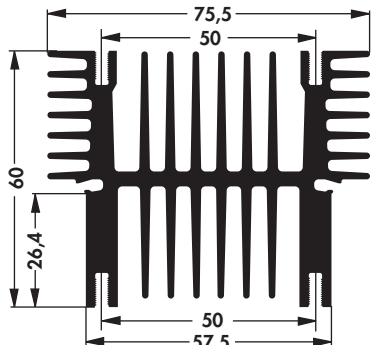
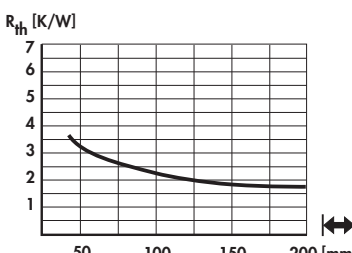
<p>art. no.</p> <p>SK 499 ...</p>			
<p>please indicate: ... $\left[\begin{array}{c} \text{---} \\ \text{---} \end{array} \right]$ 25 37.5 50 75 100 1000 mm</p>		<p>... custom processing (optional) CNC = individual CNC machining WL = desired length</p>	
<p>art. no.</p> <p>SK 487 ...</p>			
<p>please indicate: ... $\left[\begin{array}{c} \text{---} \\ \text{---} \end{array} \right]$ 25 37.5 50 75 84 100 1000 mm</p>		<p>... custom processing (optional) CNC = individual CNC machining WL = desired length</p>	
<p>art. no.</p> <p>SK 483 ...</p>			
<p>please indicate: ... $\left[\begin{array}{c} \text{---} \\ \text{---} \end{array} \right]$ 25 37.5 50 75 84 100 1000 mm</p>		<p>... custom processing (optional) CNC = individual CNC machining WL = desired length</p>	
<p>art. no.</p> <p>SK 593 ...</p>			
<p>please indicate: ... $\left[\begin{array}{c} \text{---} \\ \text{---} \end{array} \right]$ 25 37.5 50 75 84 100 1000 mm</p>		<p>... custom processing (optional) CNC = individual CNC machining WL = desired length</p>	

please note: profile threads → A 5; screw-in solder pin ELS 3 / ELS 3 B → A 127

B

C

D

E

F

G

H

I

K

L

M

N

A





Extruded heatsinks for lock-in retaining spring

B

C

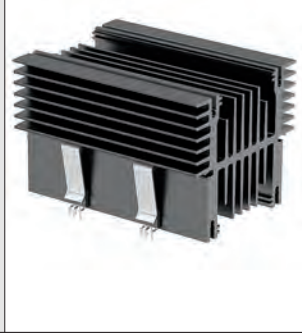
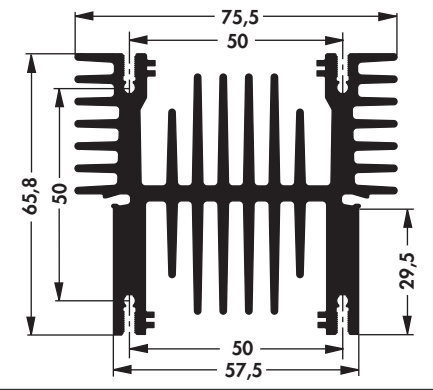
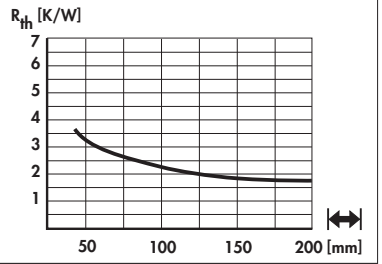
D

art. no. SK 617 ...			
please indicate: ...  25 37.5 50 75 84 94 100 1000 mm		... custom processing (optional) CNC = individual CNC machining WL = desired length	

please note: profile threads → A 5; screw-in solder pin ELS 3 / ELS 3 B → A 127

E



Screw-in solder pin ELS 3

- screw in solder pin made of brass
- easy mounting
- secure hold
- surface coating suitable for soldering
- suitable for all heatsinks with M3 profile thread
- position in the threaded channel as required
- specific designs upon customer's request

F

G

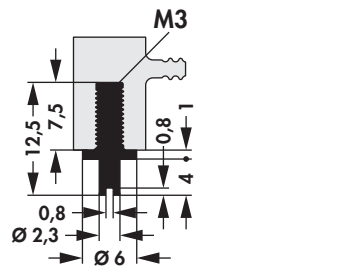
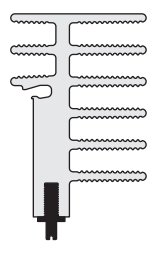
H

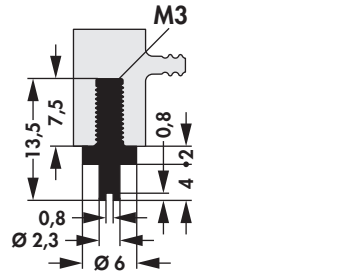
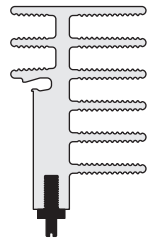
art. no. ELS 3			
art. no. ELS 3 B			

I

K

L

M

N

A 127





Technical introduction

→ A 2 – 8

Extruded heatsinks for PCB mounting

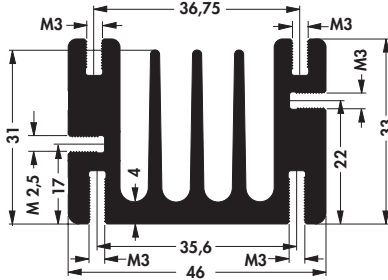
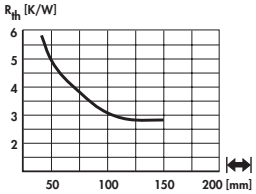
Heatsinks for printed circuit boards

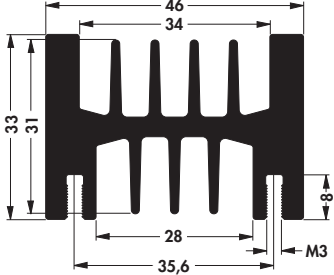
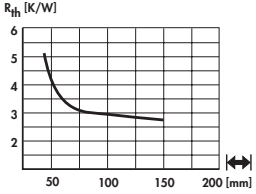
- thread channel for M3 screws
- screw-in solder pin M3 (art. no.: ELS 3 / ELS 3 B → A 127)







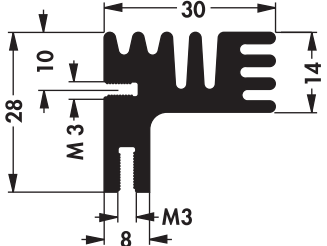
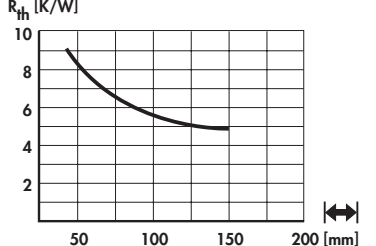

<p>art. no.</p> <p>SK 68 ...</p>			
<p>please indicate: ...  37.5 50 75 94 100 1000 mm</p>			
<p>art. no.</p> <p>SK 112 ...</p>			
<p>please indicate: ...  37.5 50 75 94 100 1000 mm</p>			

please note: profile threads → A 5

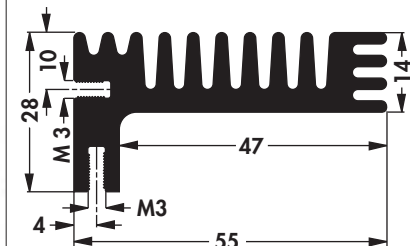
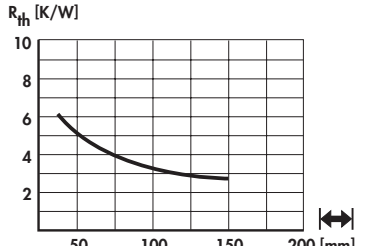
B
C
D
E
F
G
H
I
K
L
M
N

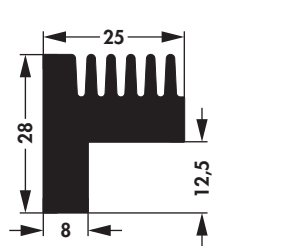
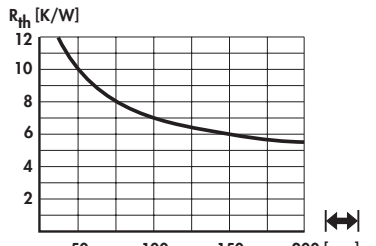

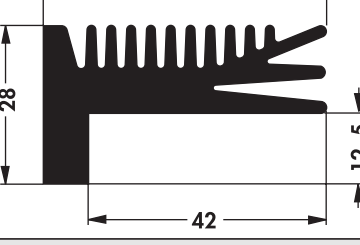
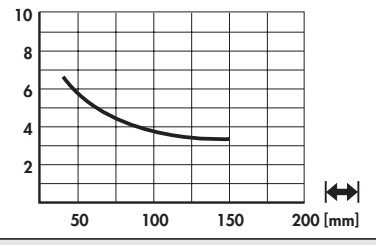
Heatsinks for printed circuit boards

– for use on eurocards

art. no.		
SK 125 ... screws M3; screw-in solder pin: art. no.: ELS 3 / ELS 3 B → A 127		
please indicate: ...  50 84 94 100 1000 mm		
art. no.		
SK 96 ... screws M3; screw-in solder pin: art. no.: ELS 3 / ELS 3 B → A 127		
please indicate: ...  50 84 94 1000 mm		
art. no.		
SK 692 ...		
please indicate: ...  50 84 94 100 1000 mm		
art. no.		
SK 138 ...		
please indicate: ...  84 94 1000 mm		

please note: profile threads → A 5

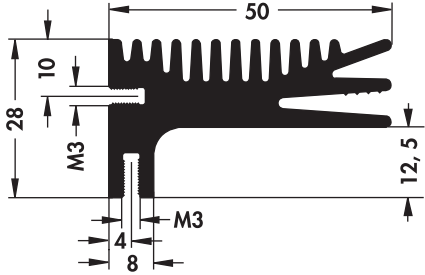
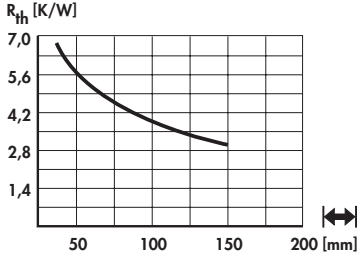
Extruded heatsinks for PCB mounting

<p>art. no.</p>	<div style="display: flex; justify-content: space-around; align-items: center;">   </div>
<p>SK 451 ...</p>	<p>screws M3; screw-in solder pin: art. no.: ELS 3 / ELS 3 B → A 127</p>
<p>please indicate: ...  50 84 94 1000 mm</p>	

B

C

D

E

F

G

H

I

K

L







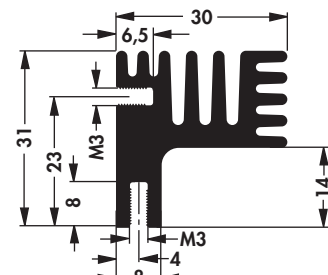
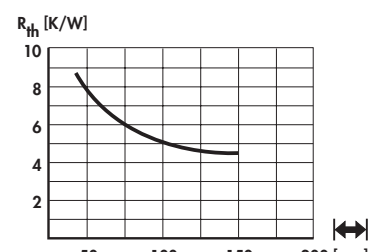

M

please note: profile threads → A 5

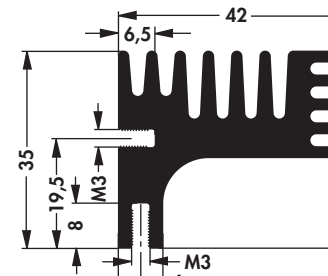
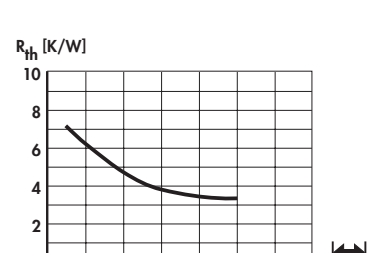
N

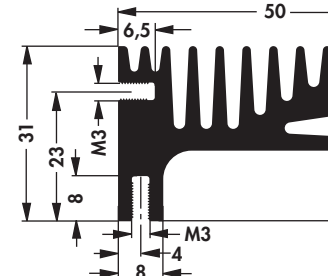
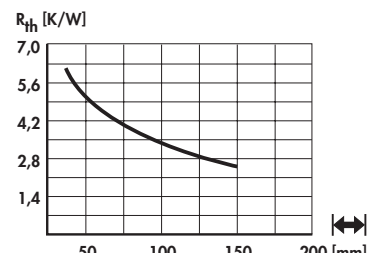
PCB heatsink

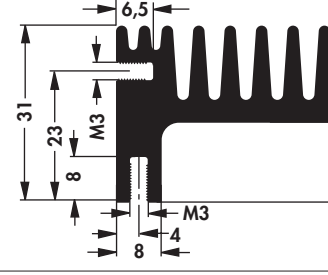
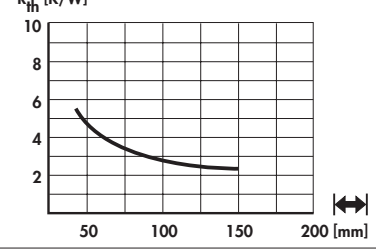
- for using eurocards
- especially suitable for power transistors
- suitable for TO 218, TO 220, TO 247, TO 264 and SOT 429

art. no.		
SK 609 ... screws M3; screw-in solder pin: art. no.: ELS 3 / ELS 3 B → A 127		
please indicate: ...  50 84 94 1000 mm		
art. no.		
SK 687 ... screws M3; screw-in solder pin: art. no.: ELS 3 / ELS 3 B → A 127		
please indicate: ...  50 84 94 100 1000 mm		
art. no.		
SK 611 ... screws M3; screw-in solder pin: art. no.: ELS 3 / ELS 3 B → A 127		
please indicate: ...  84 94 1000 mm		
... custom processing (optional) CNC = individual CNC machining WL = desired length		
art. no.		
SK 610 ... screws M3; screw-in solder pin: art. no.: ELS 3 / ELS 3 B → A 127		
please indicate: ...  50 84 94 1000 mm		

please note: profile pressed threads → A 5

Extruded heatsinks for PCB mounting

Heatsink for PCB with threaded rail

- transistor mounting onto the heatsink using a slide-in rail with M3 thread
- easy positioning using a pitch 6.35 mm
- other pitches upon request
- suitable for TO 220, TO 218, TO 247 and similar
- thread channel for M3 screws
- screw-in solder pin M3 (**art. no.: ELS 3 / ELS 3 B**)
- specific versions upon customer's request

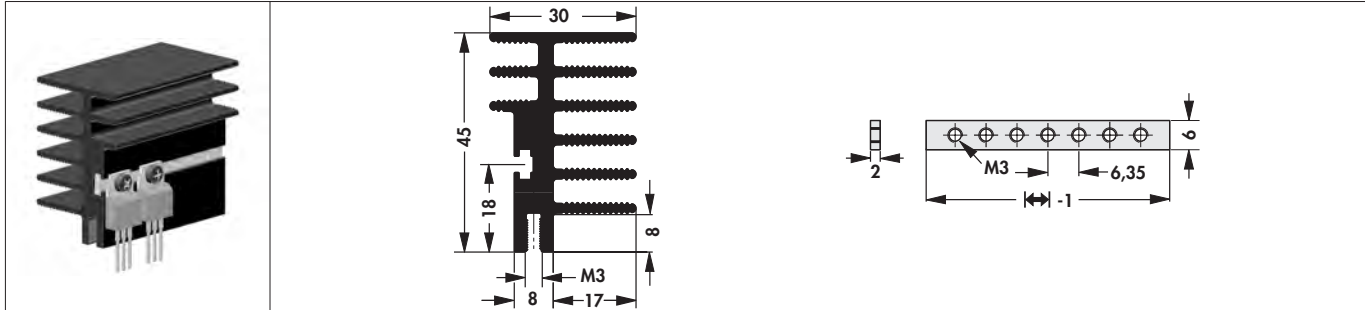











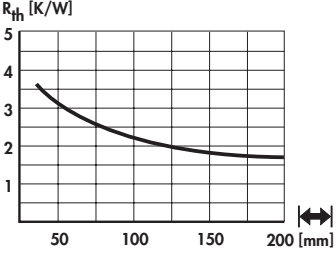

art. no.	↔ [mm]	R _{th} [K/W]	⌀	version
SK 518 50 GS	50	4.3	TO 220	with threaded rail
SK 518 75 GS	75	3.3		
SK 518 84 GS	84	3.0		
SK 518 50	50	4.3	—	without threaded rail
SK 518 75	75	3.3		
SK 518 84	84	3.0		
surface:		black anodised		

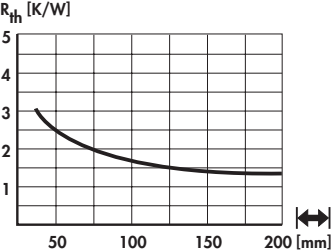
please note: profile threads → A 5

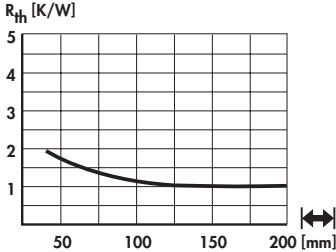

Extruded heatsinks for PCB mounting

– the heatsinks SK 105, SK 44 and SK 415 are especially suitable for printed circuit board heatsinks for 19" plug in units

art. no. SK 105 ...			
please indicate: ...  37.5 50 75 100 150 200 233.4 1000 mm			
art. no. SK 44 ...			
please indicate: ...  50 75 100 150 200 233.4 1000 mm			
art. no. SK 415 ...			
please indicate: ...  37.5 100 150 1000 mm			

Attachable heatsinks for transistors

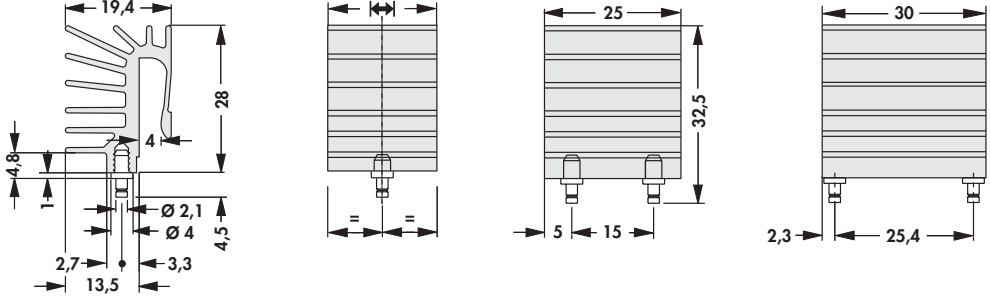
- extruded heatsink with intergrated spring locking function
- simple assembly by pushing the heatsink onto the transistor
- optimum heat transfer between component and heatsink
- solderable pin for PCB mounting
- specific versions upon customer's request

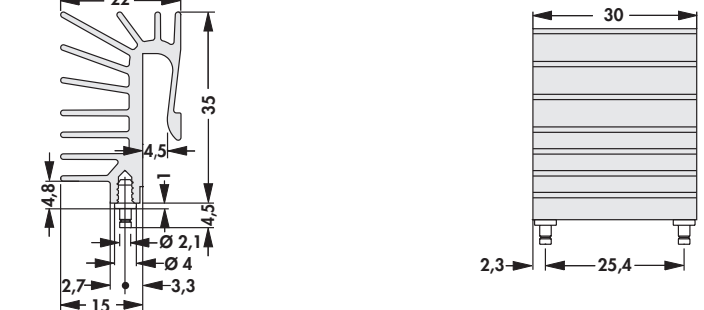
					
art. no. SK 525 15 SK 525 30 SK 525 15 ST SK 525 20 ST SK 525 25 ST SK 525 30 ST	for transistor TO 220	$\lvert\lrcorner\rvert$ [mm] 15 30 15 20 25 30	R_{th} [K/W] 13.3 7.8 13.3 10.7 9.0 7.8	spring force [N] 54 100 54 70 85 100	version without solder pins with 1 solder pin with 2 solder pins
					
art. no. SK 526 30 ST	for transistor TO 247	$\lvert\lrcorner\rvert$ [mm] 30	R_{th} [K/W] 6.3	spring force [N] 100	version with 2 solder pins
surface:		black anodised			

Extruded heatsinks for PCB mounting

Extruded heatsinks for transistors

- compact PCB heatsink
- effective heat dissipation for single and double row transistor mounting
- profile **SK 454** → A 33
- profile **SK 452** → A 36
- specific versions upon customer's request

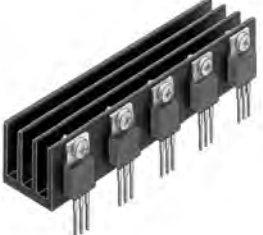
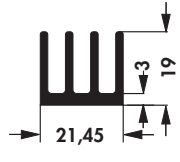
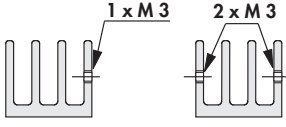
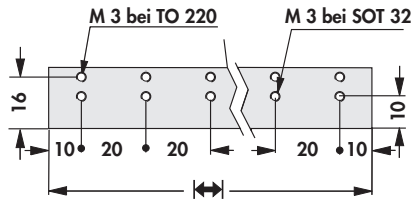
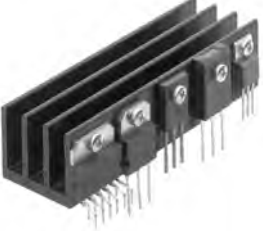
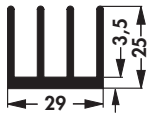
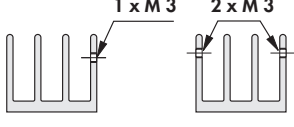
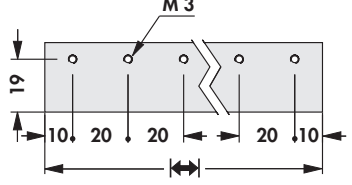
			
art. no.	↔ [mm]	R _{th} [K/W]	⊕
SK 454 20 1 x M3 ...	20	10.8	SOT 32/ TO 220
SK 454 60 3 x M3 ...	60	7.7	
SK 454 20 2 x M3 ...	20	10.8	
SK 454 40 4 x M3 ...	40	9.4	
SK 454 60 6 x M3 ...	60	7.7	
SK 454 40 2 x M3 TO 220	40	9.4	
SK 454 80 4 x M3 TO 220	80	6.5	
SK 454 100 5 x M3 TO220	100	5.9	
SK 454 80 8 x M3 TO 220	80	6.5	
SK 454 100 10xM3 TO220	100	5.9	
please indicate: ... ⊕ SOT 32; TO 220			
			
art. no.	↔ [mm]	R _{th} [K/W]	⊕
SK 452 20 1 x M3	20	11.1	TO 218/ TO 220/ TO 247/ TO 248/ TO 3 P
SK 452 40 2 x M3	40	7.5	
SK 452 60 3 x M3	60	5.9	
SK 452 80 4 x M3	80	4.9	
SK 452 100 5 x M3	100	4.3	
SK 452 20 2 x M3	20	11.1	
SK 452 40 4 x M3	40	7.5	
SK 452 60 6 x M3	60	5.9	
SK 452 80 8 x M3	80	4.9	
SK 452 100 10 x M3	100	4.3	
surface:	black anodised		

Extruded heatsinks for PCB mounting

- for semiconductor clip-mounting
- special lengths and transistor drillings upon request
- **P** = raised retaining stud, **E** = mounting method

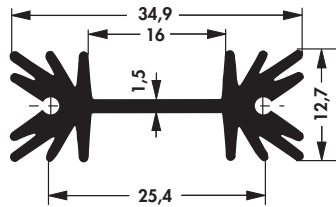
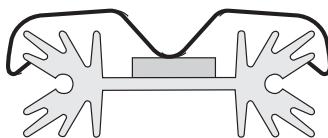
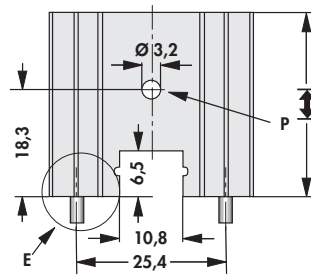
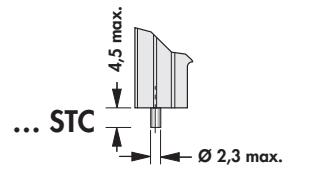
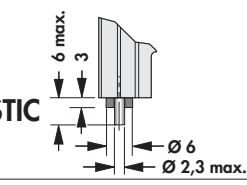
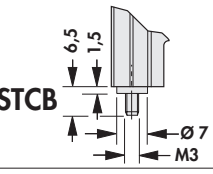
						
						
	art. no.	l [mm]			R_{th} [K/W]	TO 220
	SK 104 25,4 ...	25.4			14	
	SK 104 38,1 ...	38.1			11	
SK 104 50,8 ...	50.8	9				
SK 104 63,5 ...	63.5	8				
please indicate: ... mounting method STC = with solder pin STIC = with solder pin and insulating washer STCB = with threaded bolt M3, brass						
surface:		black anodised				

- for semiconductor screw-mounting
- special lengths and transistor drillings on request
- **E** = mounting method

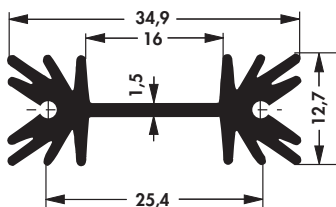
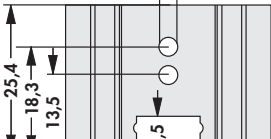
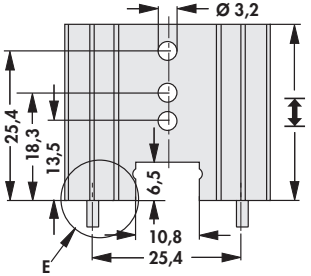
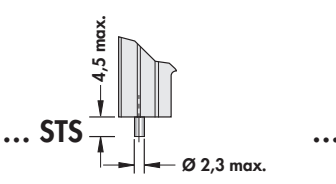
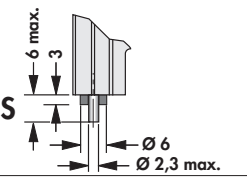
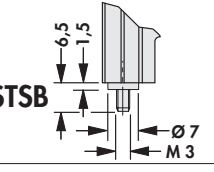
						
						
	art. no.	l [mm]			R_{th} [K/W]	SOT 32/ TO 220/ TO 3 P
	SK 104 25,4 ...	25.4			14	
	SK 104 38,1 ...	38.1			11	
SK 104 50,8 ...	50.8	9				
SK 104 63,5 ...	63.5	8				
please indicate: ... mounting method STS = with solder pin STIS = with solder pins and insulating washer STSB = with threaded bolt M3, brass						
surface:		black anodised				

Extruded heatsinks for PCB mounting

- horizontal for semiconductor screw-mounting
- special lengths and transistor drillings on request

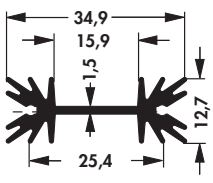
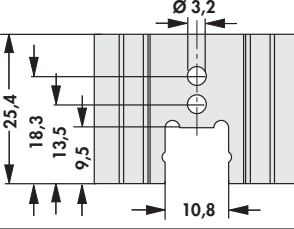
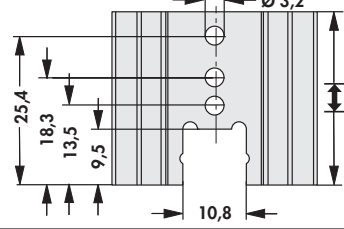
					
	art. no.	l [mm]			R _{th} [K/W]
	SK 104 25,4 LS	25.4			14
	SK 104 38,1 LS	38.1			11
SK 104 50,8 LS	50.8	9	SOT 32/ TO 220/ TO 3 P		
surface:		black anodised			

B

C

D

E

F

G

H

I

K

L

M

N

Extruded heatsinks for PCB mounting

- for semiconductor clip-mounting
- special lengths and transistor drillings on request
- **P** = raised retaining stud, **E** = mounting method

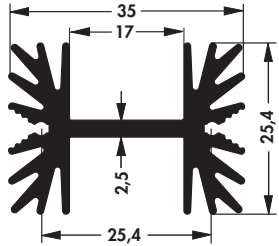
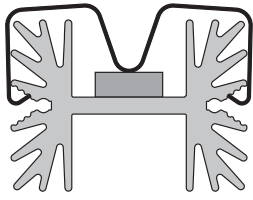
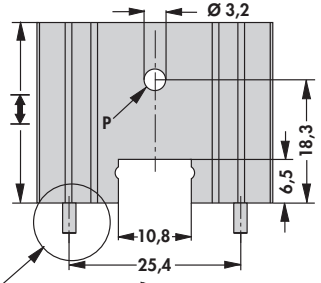
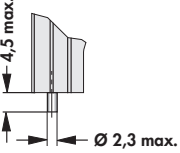
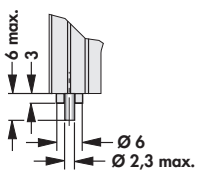
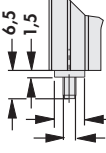
					
	 <p>... STC</p>	 <p>... STIC</p>	 <p>... STCB</p>		
art. no.	l [mm]	R _{th} [K/W]	⚡		
SK 600 25,4 ...	25.4	11.0	TO 218/ TO 220/ TO 247/ TO 3 P		
SK 600 38,1 ...	38.1	9.0			
SK 600 50,8 ...	50.8	7.3			
SK 600 63,5 ...	63.5	6.5			
please indicate:	... mounting method STC = with solder pin STIC = with solder pin and insulating washer STCB = with threaded bolt M3, brass				
surface:	black anodised				

- for semiconductor screw-mounting
- special lengths and transistor drillings on request
- **E** = mounting method

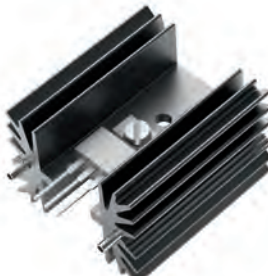
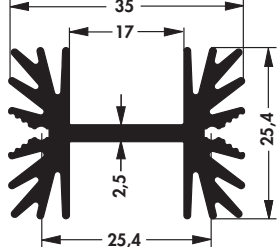
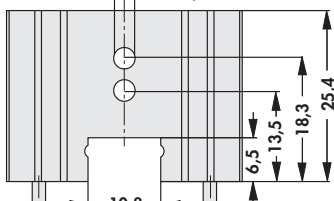
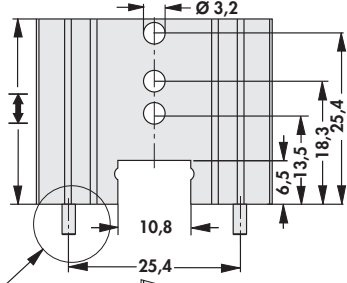
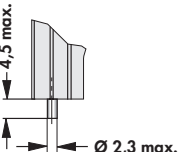
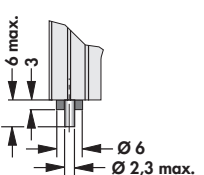
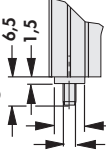
					
	 <p>... STS</p>	 <p>... STIS</p>	 <p>... STSB</p>		
art. no.	l [mm]	R _{th} [K/W]	⚡		
SK 600 25,4 ...	25.4	11.0	TO 218/ TO 220/ TO 247/ TO 3 P		
SK 600 38,1 ...	38.1	9.0			
SK 600 50,8 ...	50.8	7.3			
SK 600 63,5 ...	63.5	6.5			
please indicate:	... mounting method STS = with solder pin STIS = with solder pins and insulating washer STSB = with threaded bolt M3, brass				
surface:	black anodised				

Extruded heatsinks for PCB mounting

- for semiconductor clip-mounting
- special lengths and transistor drillings on request
- **P** = raised retaining stud, **E** = mounting method

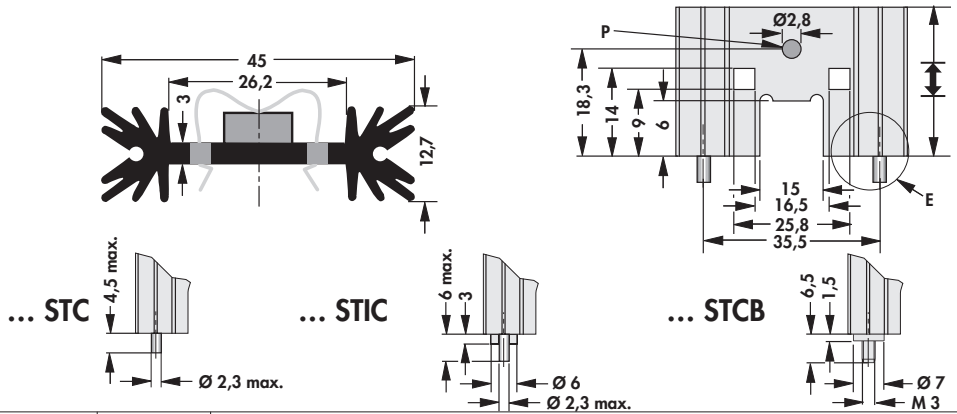



art. no.	l [mm]	R _{th} [K/W]	
SK 409 25,4 ...	25.4	8.2	TO 220/ TO 3 P
SK 409 38,1 ...	38.1	7.0	
SK 409 50,8 ...	50.8	6.2	
SK 409 63,5 ...	63.5	5.6	

please indicate: ... mounting method
STC = with solder pin
STIC = with solder pin and insulating washer
STCB = with threaded bolt M3, brass

surface: black anodised

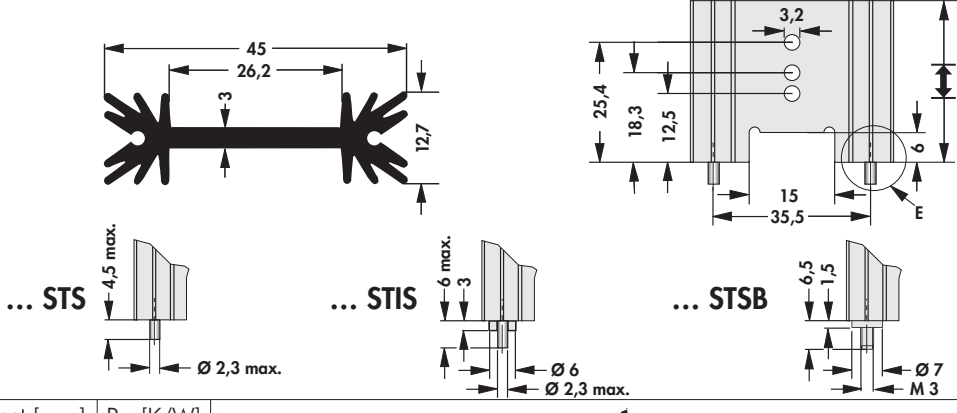
- for semiconductor screw-mounting
- special lengths and transistor drillings on request
- **E** = mounting method

art. no.	l [mm]	R _{th} [K/W]	
SK 409 25,4 ...	25.4	8.2	TO 220/ TO 3 P
SK 409 38,1 ...	38.1	7.0	
SK 409 50,8 ...	50.8	6.2	
SK 409 63,5 ...	63.5	5.6	

please indicate: ... mounting method
STS = with solder pin
STIS = with solder pins and insulating washer
STSB = with threaded bolt M3, brass



surface: black anodised

Extruded heatsinks for PCB mounting

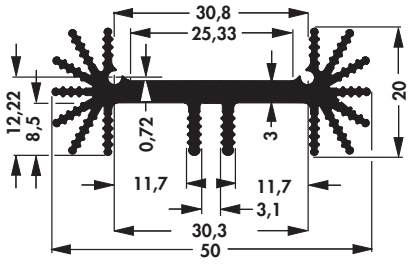
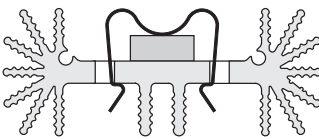
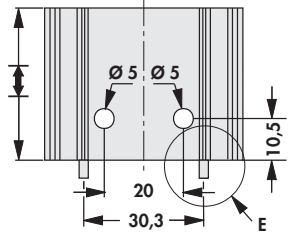
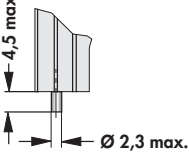
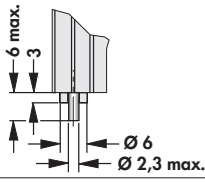
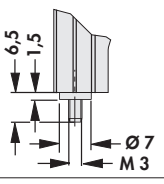
- for semiconductor clip-mounting
- special lengths and transistor drillings on request
- **E** = mounting method

					
					
art. no.	↔ [mm]	R_{th} [K/W]	⊕		
SK 459 25 ...	25.0	7.9	TO 218/ TO 220/ TO 247/ TO 248		
SK 459 37,5 ...	37.5	6.3			
SK 459 50 ...	50.0	5.6			
please indicate: ... mounting method STC = with solder pin STIC = with solder pin and insulating washer STCB = with threaded bolt M3, brass					

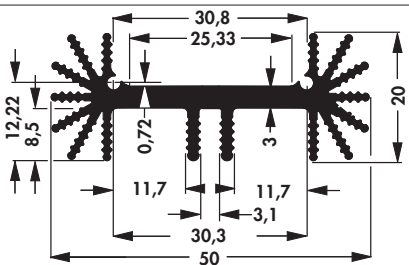
- for semiconductor screw-mounting
- special lengths and transistor drillings on request
- **E** = mounting method

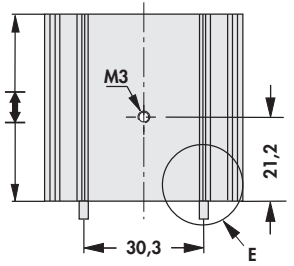
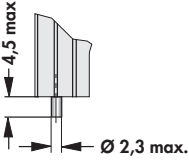
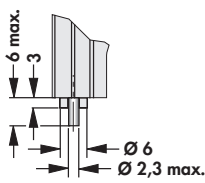
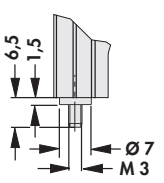
					
					
art. no.	↔ [mm]	R_{th} [K/W]	⊕		
SK 459 25 ...	25.0	7.9	TO 218/ TO 220/ TO 247/ TO 248		
SK 459 37,5 ...	37.5	6.3			
SK 459 50 ...	50.0	5.6			
please indicate: ... mounting method STS = with solder pin STIS = with solder pins and insulating washer STSB = with threaded bolt M3, brass					

Extruded heatsinks for PCB mounting

- for semiconductor screw-mounting
- special lengths and transistor drillings on request
- **E** = mounting method

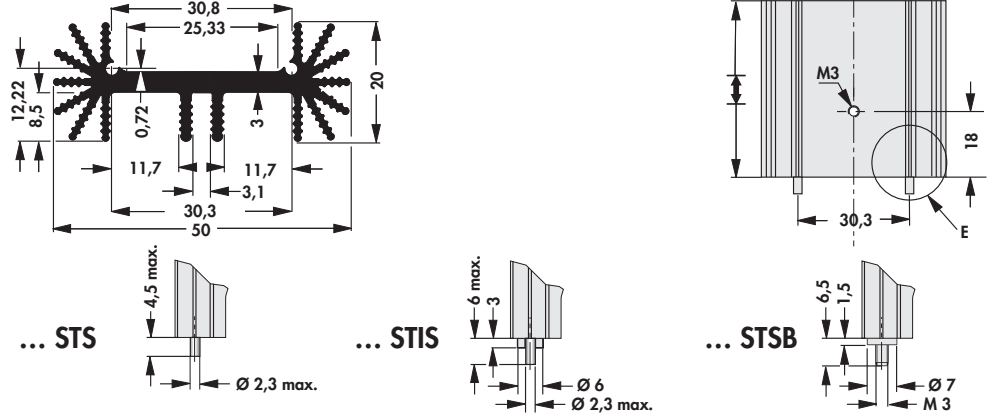



art. no.	l [mm]	R _{th} [K/W]	⌀
SK 459 25 M ...	25.0	7.9	SIP-Multiwatt
SK 459 37,5 M ...	37.5	6.3	
SK 459 50 M ...	50.0	5.6	

please indicate: ... mounting method
STS = with solder pin
STIS = with solder pins and insulating washer
STSB = with threaded bolt M3, brass

surface: black anodised

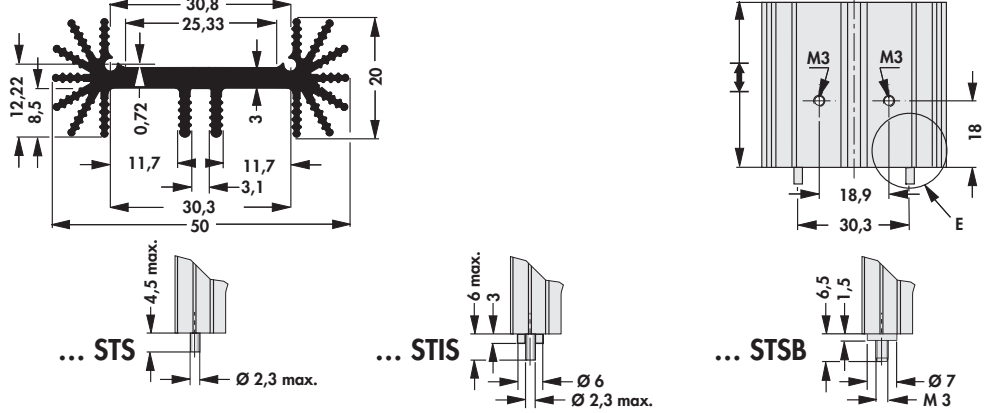
- for semiconductor screw-mounting
- with **combination-hole pattern** for mounting of 2 x TO 220 or 2 x SOT 32
- special lengths and transistor drillings on request
- **E** = mounting method



art. no.	l [mm]	R _{th} [K/W]	⌀
SK 459 25 2 x TO 220 ...	25.0	7.9	2 x SOT 32/ 2xTO 220
SK 459 37,5 2 x TO 220...	37.5	6.3	
SK 459 50 2 x TO 220 ...	50.0	5.6	

please indicate: ... mounting method
STS = with solder pin
STIS = with solder pins and insulating washer
STSB = with threaded bolt M3, brass

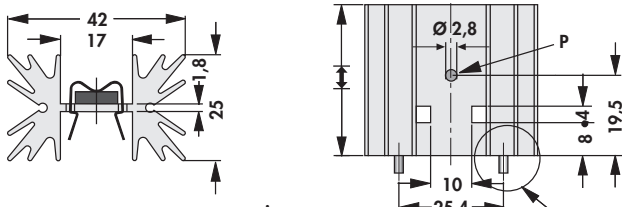
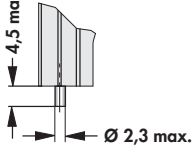
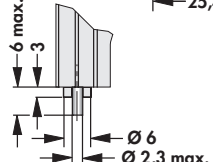
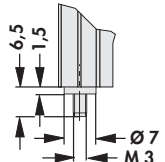

surface: black anodised

Extruded heatsinks for PCB mounting

- for semiconductor clip-mounting
- special lengths and transistor drillings on request
- **P** = raised retaining stud, **E** = mounting method

				
				
	art. no.	↳ [mm]	R_{th} [K/W]	 TO 220
	SK 129 25,4 ...	25.4	7.8	
	SK 129 38,1 ...	38.1	6.5	
SK 129 50,8 ...	50.8	5.3		
SK 129 63,5 ...	63.5	4.5		
please indicate:				
... mounting method STC = with solder pin STIC = with solder pin and insulating washer STCB = with threaded bolt M3, brass				

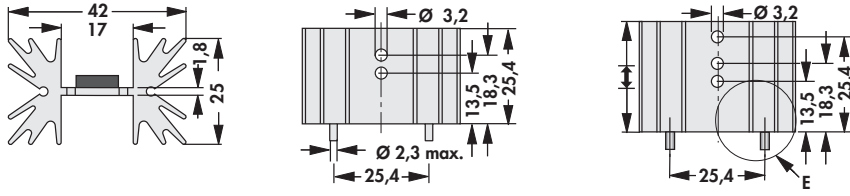
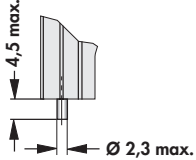
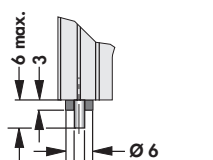
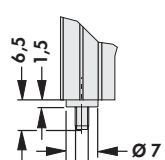
- for semiconductor screw-mounting
- special lengths and transistor drillings on request
- **E** = mounting method

				
				
	art. no.	↳ [mm]	R_{th} [K/W]	 SOT 32/ TO 220/ TO 3 P
	SK 129 25,4 ...	25.4	7.8	
	SK 129 38,1 ...	38.1	6.5	
SK 129 50,8 ...	50.8	5.3		
SK 129 63,5 ...	63.5	4.5		
please indicate:				
... mounting method STS = with solder pin STIS = with solder pins and insulating washer STSB = with threaded bolt M3, brass				

Extruded heatsinks for PCB mounting

- for semiconductor clip-mounting
- profile **SK 185** → A 106
- special lengths and drillings on request
- **L** = solderable pins

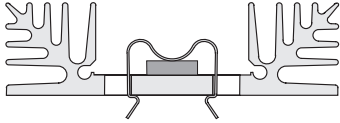
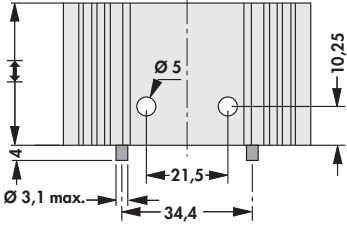

				
art. no.	l [mm]	R _{th} [K/W]	Ø	version
SK 185 25 STC TO 220	25.0	7.9	TO 220	with solder pins
SK 185 37,5 STC TO 220	37.5	6.4		
SK 185 50 STC TO 220	50.0	4.9		without solder pins
SK 185 50 C TO 220				
surface:		black anodised		

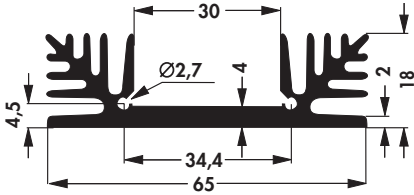
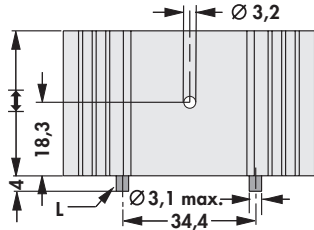
- for semiconductor screw-mounting
- profile **SK 185** → A 106
- special lengths and drillings on request
- **L** = solderable pins

				
art. no.	l [mm]	R _{th} [K/W]	Ø	version
SK 185 25 STS TO 220	25.0	7.9	TO 220	with solder pins
SK 185 37,5 STS TO 220	37.5	6.4		
SK 185 50 STS TO 220	50.0	4.9		without solder pins
SK 185 25 TO 220	25.0	7.9		
SK 185 37,5 TO 220	37.5	6.4		
SK 185 50 TO 220	50.0	4.9		
surface:		black anodised		

Extruded heatsinks for PCB mounting

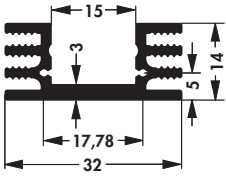
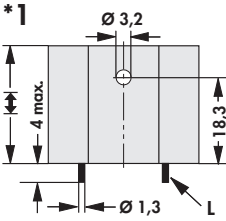
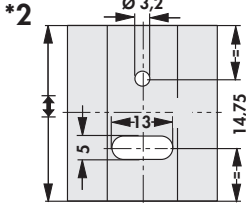
- for semiconductor screw-mounting
- hole pattern is centered to the total length of the heatsink
- special lengths and drillings on request
- ***1** = versions with solder pins; ***2** = versions without solder pins
- **L** = solderable pins

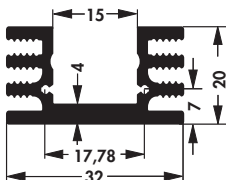
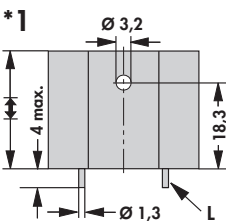
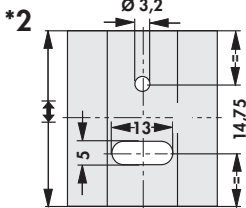
					
art. no.	< > [mm]	R_{th} [K/W]	⌀	version	
SK 75 25 STS TO 220	25.0	12.5	TO 220/*1	with solder pins	
SK 75 37,5 STS TO 220	37.5	10.0			
SK 75 50 STS TO 220	50.0	8.5			
SK 75 25	25.0	12.5	—	without solder pins	
SK 75 25 TO 220			TO 220/*2		
SK 75 37,5	37.5	10.0	—		
SK 75 37,5 TO 220			TO 220/*2		
SK 75 50	50.0	8.5	—		
SK 75 50 TO 220			TO 220/*2		
SK 75 75	75.0	7.0	—		
SK 75 1000	1000.0	—	—		
					
art. no.	< > [mm]	R_{th} [K/W]	⌀		version
SK 76 25 STS TO 220	25.0	10.0	TO 220/*1	with solder pins	
SK 76 37,5 STS TO 220	37.5	8.0			
SK 76 50 STS TO 220	50.0	7.0			
SK 76 25	25.0	10.0	—	without solder pins	
SK 76 25 TO 220			TO 220/*2		
SK 76 37,5	37.5	8.0	—		
SK 76 37,5 TO 220			TO 220/*2		
SK 76 50	50.0	7.0	—		
SK 76 50 TO 220			TO 220/*2		
SK 76 75	75.0	5.9	—		
SK 76 1000	1000.0	—	—		
surface:		black anodised			

Extruded heatsinks for PCB mounting

- for semiconductor clip-mounting
- profile **SK 145** → A 91
- special lengths and drillings on request
- **L** = solderable pins

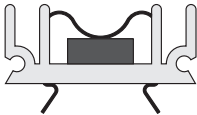
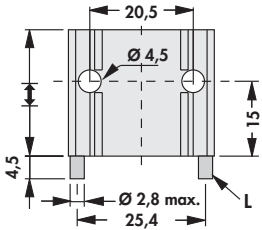
				
art. no.	↔ [mm]	R _{th} [K/W]	⊗	version
SK 145 25 STC	25	13.5	TO 218/ TO 220/ TO 247/ TO 248	with solder pins
SK 145 30 STC	30	12.4		
SK 145 50 STC	50	10.0		
surface:		black anodised		

- for semiconductor screw-mounting
- profile **SK 145** → A 91
- special lengths and drillings on request
- **L** = solderable pins

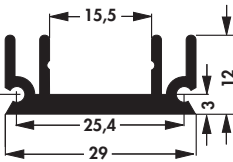
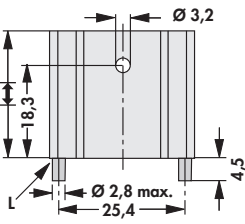
				
art. no.	↔ [mm]	R _{th} [K/W]	⊗	version
SK 145 25 STS TO 220	25.0	13.5	TO 218/ TO 220/ TO 247/ TO 248	with solder pins
SK 145 37,5 STS TO 220	37.5	12.0		
SK 145 50 STS TO 220	50.0	10.0		
surface:		black anodised		

B

C

D

E

F

G

H

I

K

L

M

N

Extruded heatsinks for PCB mounting

- special lengths and drillings on request
- **L** = solderable pins

art. no.	[mm]	R _{th} [K/W]	⌀	version
				with solder pin and thread M3
SK 126 25 STS TO 220	25.0	13.0	TO 218/ TO 220/ TO 247/ TO 248	without solder pin, with M3 thread
SK 126 37,5 STS TO 220	37.5	9.5		
SK 126 25 TO 220	25.0	13.0		
SK 126 25 2 x M3	25.0	13.0		
SK 126 37,5 TO 220	37.5	9.5	—	—
SK 126 37,5 2 x M3	37.5	9.5		
SK 126 25	25.0	13.0		
SK 126 37,5	37.5	9.5	—	—
SK 126 1000	1000.0	—	—	—
surface:		black anodised		



SK 126 25 TO 220
SK 126 37,5 TO 220

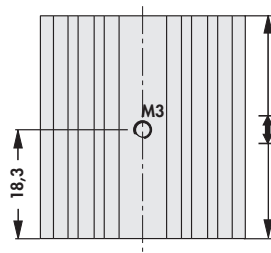
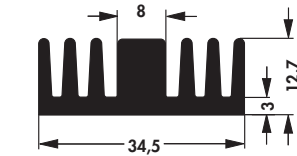

SK 126 25 STS TO 220
SK 126 37,5 STS TO 220

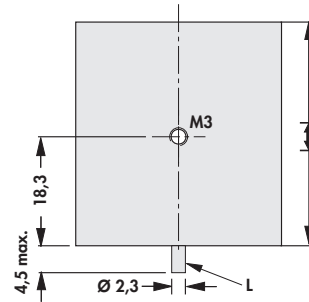
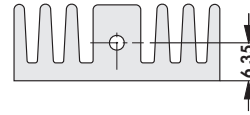

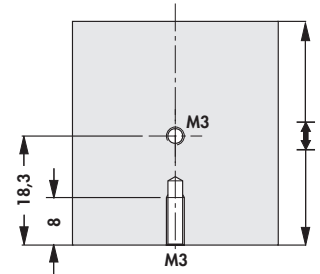
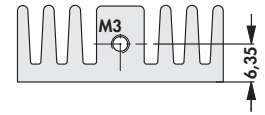

SK 126 25 2 x M3
SK 126 37,5 2 x M3



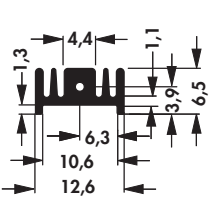
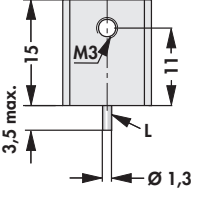
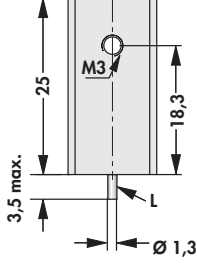
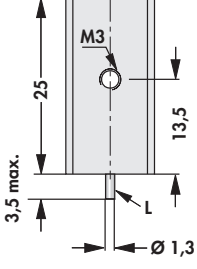

Extruded heatsinks for PCB mounting

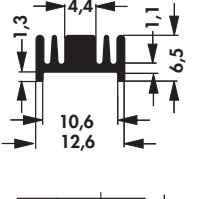
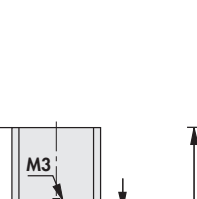
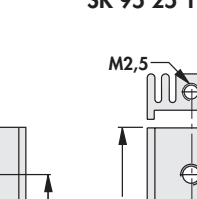
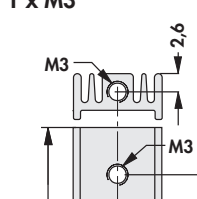
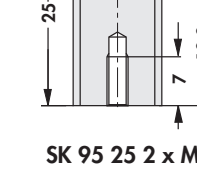
- special lengths and drillings on request
- L = solderable pins

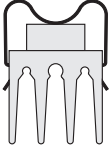
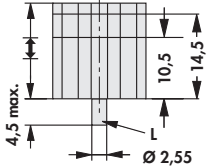

	 			
	SK 95 15 STS SOT 32 S	SK 95 25 STS TO 220	SK 95 25 STS SOT 32	
art. no.	> [mm]	R _{th} [K/W]	⊕	
SK 95 15 STS SOT 32 S	15	38.5	SOT 32	
SK 95 25 STS SOT 32	25	36.0	TO 220	
SK 95 25 STS TO 220				
	 		<p align="center">SK 95 25 1 x M2,5 1 x M3</p>  	
	SK 95 15 SOT 32 S	SK 95 25 SOT 32	SK 95 25 TO 220	SK 95 25 2 x M3
art. no.	> [mm]	R _{th} [K/W]	⊕	
SK 95 15 SOT 32 S	15	38.5	SOT 32	
SK 95 25 SOT 32	25	36.0	TO 220	
SK 95 25 TO 220				
SK 95 25 1x M2,5 1x M3			1xM2.5/ 1xM3 (TO 220)	
SK 95 25 2 x M3			2xM3 (TO 220)	
SK 95 15	15	38.5		
SK 95 25	25	36.0	—	
SK 95 1000	1000	—		
surface:	black anodised			
type of thread:	not anodised			

Extruded heatsinks for PCB mounting

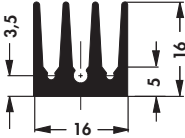
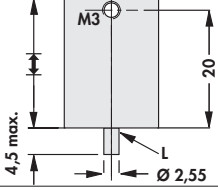

- single solder pin
- profile **SK 437** → A 31
- special lengths and drillings on request
- **L** = solderable pin

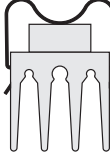
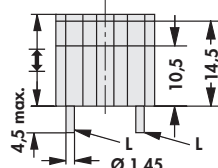
			
art. no.	↔ [mm]	R _{th} [K/W]	⊕
SK 437 25 STC	25	24	TO 218/ TO 220/ TO 247/ TO 248
SK 437 30 STC	30	22	
SK 437 35 STC	35	18	
SK 437 50 STC	50	14	
			
art. no.	↔ [mm]	R _{th} [K/W]	⊕
SK 437 25 STS	25	24	TO 218/ TO 220/ TO 247/ TO 248
SK 437 30 STS	30	22	
SK 437 35 STS	35	18	
SK 437 50 STS	50	14	
surface:		black anodised	

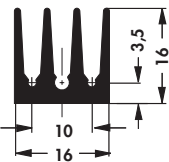
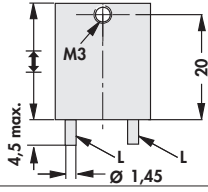
- double solder pin
- profile **SK 437** → A 31
- special lengths and drillings on request
- **L** = solderable pin

			
art. no.	↔ [mm]	R _{th} [K/W]	⊕
SK 437 25 STC 2	25	24	TO 218/ TO 220/ TO 247/ TO 248
SK 437 30 STC 2	30	22	
SK 437 35 STC 2	35	18	
			
art. no.	↔ [mm]	R _{th} [K/W]	⊕
SK 437 25 STS 2	25	24	TO 218/ TO 220/ TO 247/ TO 248
SK 437 30 STS 2	30	22	
SK 437 35 STS 2	35	18	
surface:		black anodised	

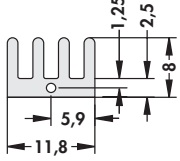
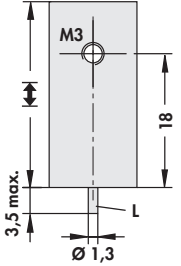
- special versions on customer's request
- L = solderable pin

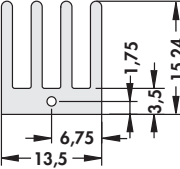
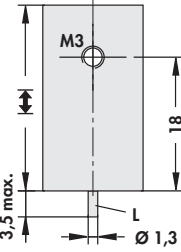



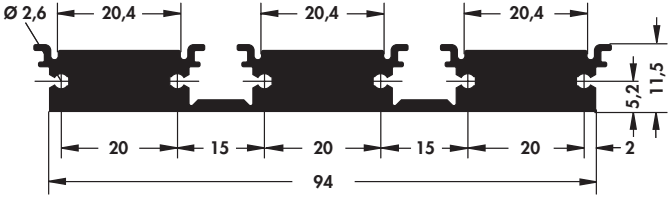

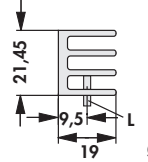
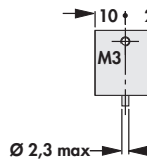
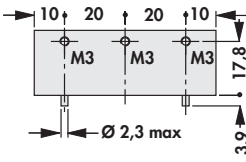

			
art. no.	↔ [mm]	R _{th} [K/W]	⚡
SK 470 25 STS	25	29.0	SOT 32/ TO 220
SK 470 30 STS	30	27.2	
SK 470 35 STS	35	25.6	
SK 470 50 STS	50	23.2	
			
art. no.	↔ [mm]	R _{th} [K/W]	⚡
SK 469 25 STS	25	15.3	SOT 32/ TO 220
SK 469 30 STS	30	14.3	
SK 469 35 STS	35	13.0	
SK 469 50 STS	50	10.6	
surface:		black anodised	

- as mounting- and connecting piece
- for clamp mounting of the transistors
- triple unit can be separated
- solder pin mounting possible
- special versions on customer's request

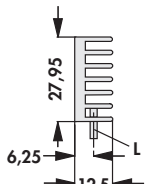
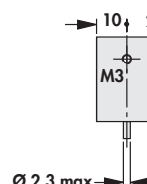
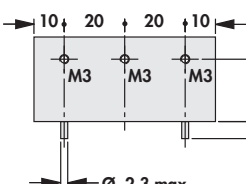
			
art. no.	↔ [mm]	R _{th} [K/W]	⚡
SK 484 25	25.0	6.0	TO 218/ TO 220/ TO 247/ TO 264/ TO 3 P
SK 484 37,5	37.5	4.5	
SK 484 50	50.0	3.7	
SK 484 75	75.0	2.8	

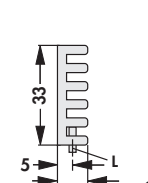
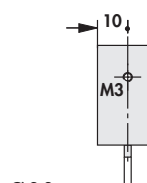
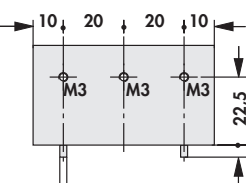
Extruded heatsinks for PCB mounting

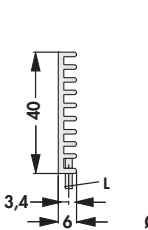
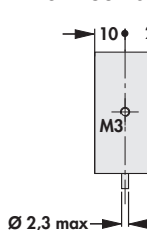
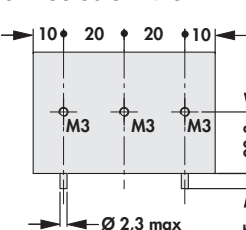
- compact PCB heatsinks
- especially suitable for vertical PCB mounting in housings, racks etc.
- easy solder fixing
- special versions on customer's request
- **L** = solderable pin

	<p style="text-align: center;">SK 454 20 1 x M 3 L</p> 	<p style="text-align: center;">SK 454 40 2 x M 3 L</p> 	<p style="text-align: center;">SK 454 60 3 x M 3 L</p> 
<p style="text-align: center;">art. no.</p>	<p style="text-align: center;"> [mm]</p>	<p style="text-align: center;">R_{th} [K/W]</p>	
<p>SK 454 20 1 x M 3 L</p>	<p style="text-align: center;">20</p>	<p style="text-align: center;">10.1</p>	<p>SOT 32/ TO 220</p>
<p>SK 454 40 2 x M 3 L</p>	<p style="text-align: center;">40</p>	<p style="text-align: center;">8.8</p>	
<p>SK 454 60 3 x M 3 L</p>	<p style="text-align: center;">60</p>	<p style="text-align: center;">7.5</p>	
	<p style="text-align: center;">SK 448 20 1 x M 3 L</p> 	<p style="text-align: center;">SK 448 40 2 x M 3 L</p> 	<p style="text-align: center;">SK 448 60 3 x M 3 L</p> 
<p style="text-align: center;">art. no.</p>	<p style="text-align: center;"> [mm]</p>	<p style="text-align: center;">R_{th} [K/W]</p>	
<p>SK 448 20 1 x M 3 L</p>	<p style="text-align: center;">20</p>	<p style="text-align: center;">11.8</p>	<p>TO 218/ TO 220/ TO 247/ TO 248/ TO 3 P</p>
<p>SK 448 40 2 x M 3 L</p>	<p style="text-align: center;">40</p>	<p style="text-align: center;">9.8</p>	
<p>SK 448 60 3 x M 3 L</p>	<p style="text-align: center;">60</p>	<p style="text-align: center;">7.1</p>	
	<p style="text-align: center;">SK 400 20 1 x M 3 L</p> 	<p style="text-align: center;">SK 400 40 2 x M 3 L</p> 	<p style="text-align: center;">SK 400 60 3 x M 3 L</p> 
<p style="text-align: center;">art. no.</p>	<p style="text-align: center;"> [mm]</p>	<p style="text-align: center;">R_{th} [K/W]</p>	
<p>SK 400 20 1 x M 3 L</p>	<p style="text-align: center;">20</p>	<p style="text-align: center;">11.6</p>	<p>TO 218/ TO 220/ TO 247/ TO 248/ TO 3 P</p>
<p>SK 400 40 2 x M 3 L</p>	<p style="text-align: center;">40</p>	<p style="text-align: center;">8.2</p>	
<p>SK 400 60 3 x M 3 L</p>	<p style="text-align: center;">60</p>	<p style="text-align: center;">7.2</p>	
	<p style="text-align: center;">SK 456 20 1 x M 3 L</p> 	<p style="text-align: center;">SK 456 40 2 x M 3 L</p> 	<p style="text-align: center;">SK 456 60 3 x M 3 L</p> 
<p style="text-align: center;">art. no.</p>	<p style="text-align: center;"> [mm]</p>	<p style="text-align: center;">R_{th} [K/W]</p>	
<p>SK 456 20 1 x M 3 L</p>	<p style="text-align: center;">20</p>	<p style="text-align: center;">13.0</p>	<p>TO 218/ TO 220/ TO 247/ TO 248/ TO 3 P</p>
<p>SK 456 40 2 x M 3 L</p>	<p style="text-align: center;">40</p>	<p style="text-align: center;">10.5</p>	
<p>SK 456 60 3 x M 3 L</p>	<p style="text-align: center;">60</p>	<p style="text-align: center;">8.5</p>	
<p>surface:</p>	<p>black anodised</p>		

Extruded heatsinks for PCB mounting

- for semiconductor clip-mounting
- special lengths and transistor drillings on request
- **E** = mounting method

	<p>... STC</p>		<p>... STIC</p>		<p>... STCB</p>	
	art. no.	↔ [mm]	R_{th} [K/W]	⊕		
	SK 460 25 ...	25.0	9.0	SIP-Multiwatt/ TO 218/ TO 220/ TO 247/ TO 248		
	SK 460 37,5 ...	37.5	7.9			
SK 460 50 ...	50.0	7.0				
<p>please indicate: ... mounting method</p> <p>STC = with solder pin</p> <p>STIC = with solder pin and insulating washer</p> <p>STCB = with threaded bolt M3, brass</p>						
surface:		black anodised				

- for semiconductor screw-mounting
- special lengths and transistor drillings on request
- **E** = mounting method

	<p>STS</p>		<p>STIS</p>			
	art. no.	↔ [mm]	R_{th} [K/W]	⊕		
	SK 460 25 STS	25.0	9.0	SIP-Multiwatt/ TO 218/ TO 220/ TO 247/ TO 248		
	SK 460 37,5 STS	37.5	7.9			
SK 460 50 STIS	50.0	7.0				
surface:		black anodised				

– special versions on customer's request

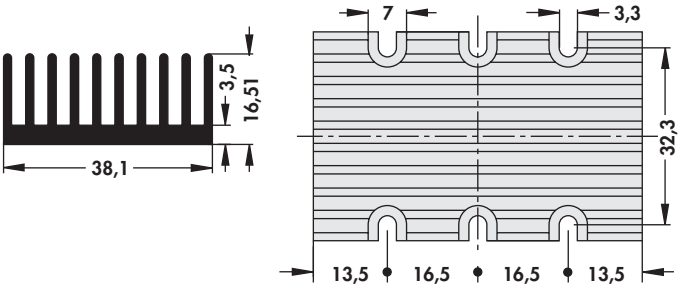
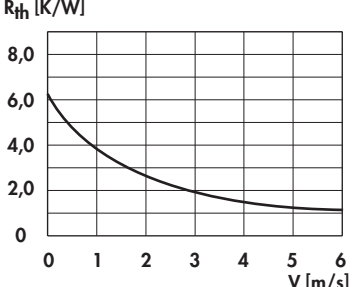
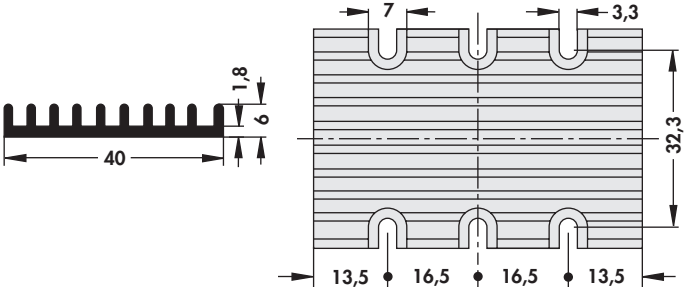
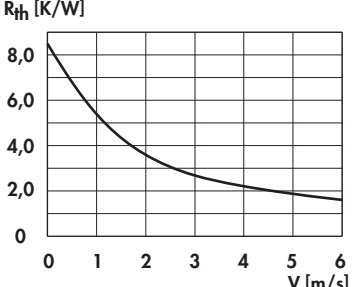
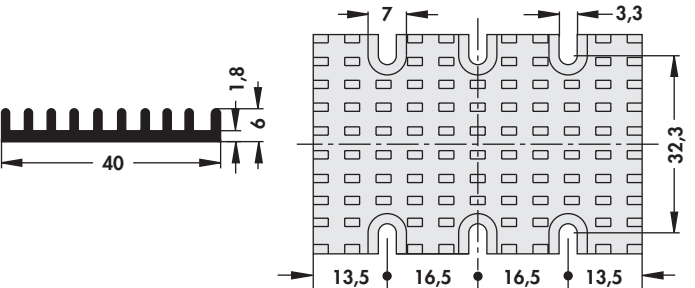
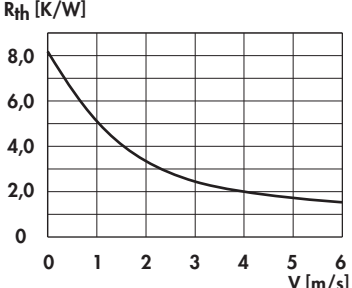
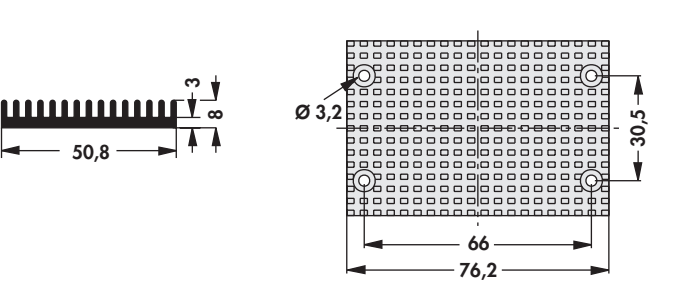
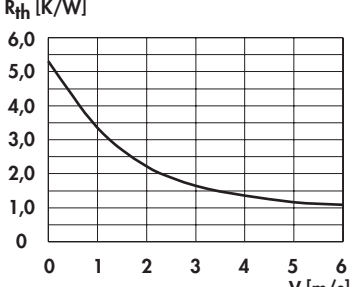
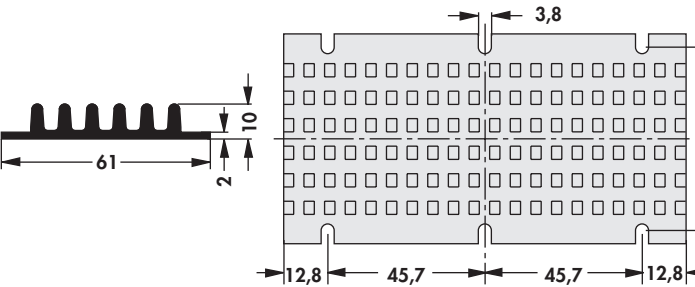
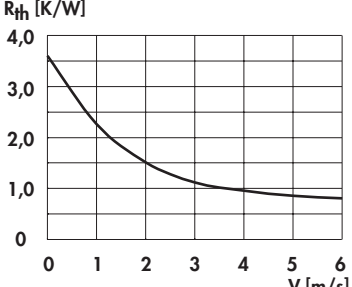
art. no. SK DC 10 60 SA		
art. no. SK DC 8 60 SA		
art. no. SK DC 8 1 60 SA		
art. no. SK DC 2 1 76 SA		
art. no. SK DC 4 1 117 SA		
surface:	black anodised	

– special versions on customer's request

<p>art. no.</p> <p>SK DC 6 1 60 SA</p>		
<p>art. no.</p> <p>SK DC 7 117 SA</p>		
<p>art. no.</p> <p>SK DC 7 1 117 SA</p>		
<p>art. no.</p> <p>SK DC 5 59 SA</p>		
<p>art. no.</p> <p>SK DC 5 1 59 SA</p>		
<p>surface:</p>		<p>black anodised</p>

Extruded heatsinks for DC/DC converter

- extruded heatsinks for 1/4 brick
- special versions on customer's request

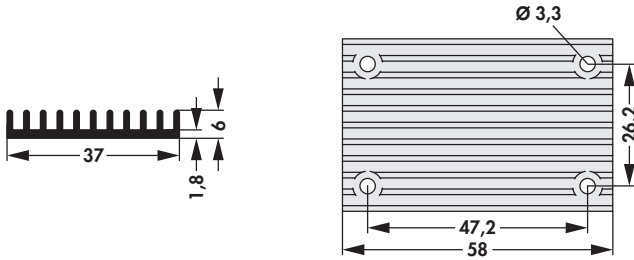
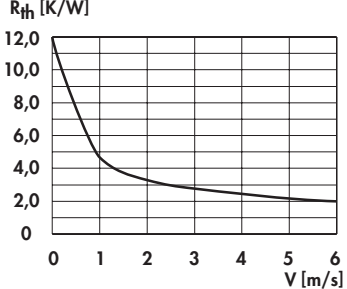
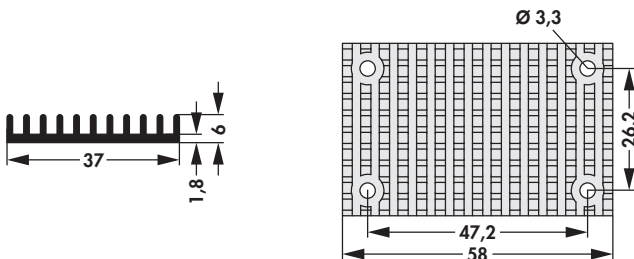
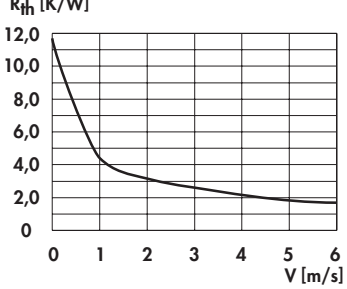
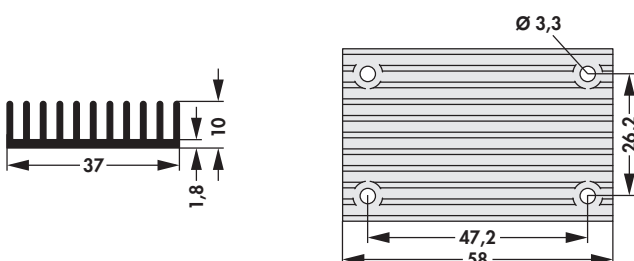
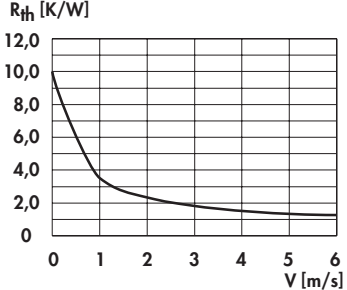
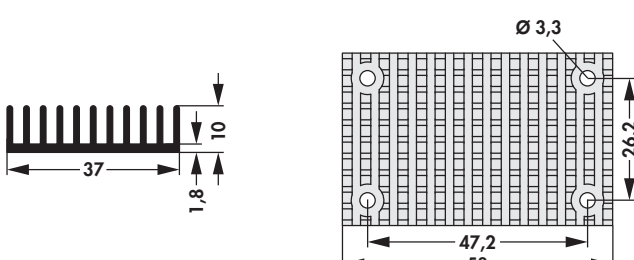
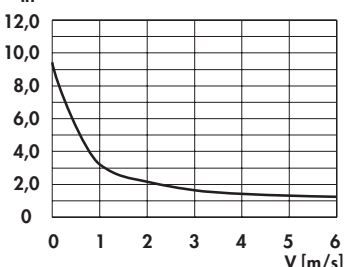
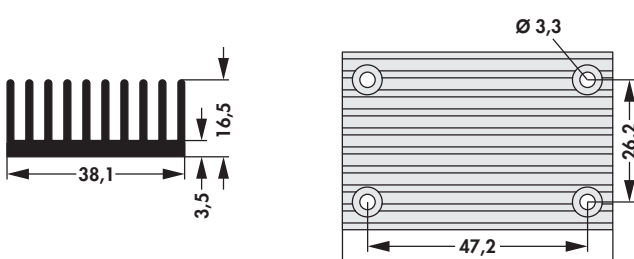
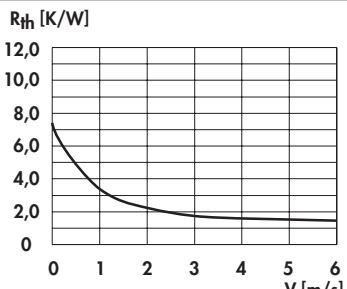
art. no. SK DC 11 58 06 SA		
art. no. SK DC 11 1 58 06 SA		
art. no. SK DC 12 58 10 SA		
art. no. SK DC 12 1 58 10 SA		
art. no. SK DC 13 58 16,5 SA		
surface:		black anodised

- extruded heatsinks for 1/4 brick
- special versions on customer's request

<p>art. no.</p> <p>SK DC 13 1 58 16,5 SA</p>		
<p>art. no.</p> <p>SK DC 14 37 20 SA</p>		
<p>art. no.</p> <p>SK DC 14 1 37 20 SA</p>		
<p>surface:</p>		<p>black anodised</p>

Extruded heatsinks for DC/DC converter

- extruded heatsinks for 1/8 brick
- special versions on customer's request

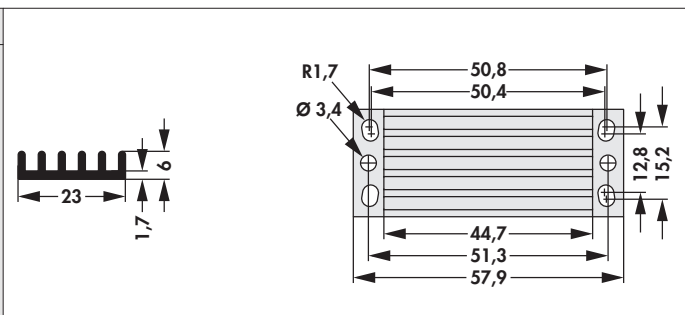
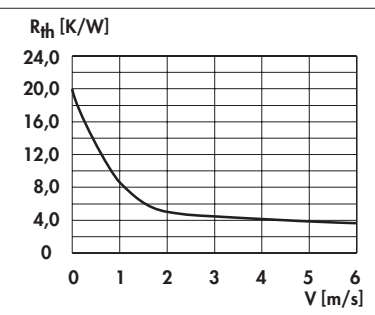
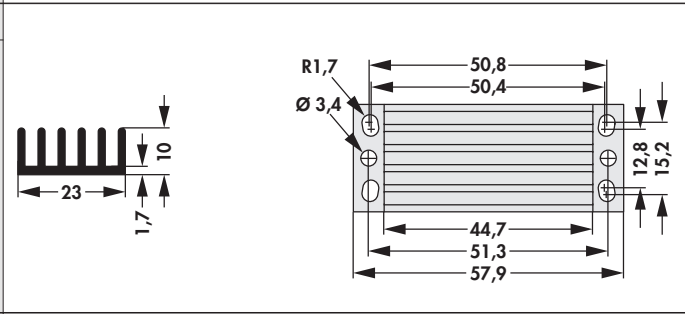
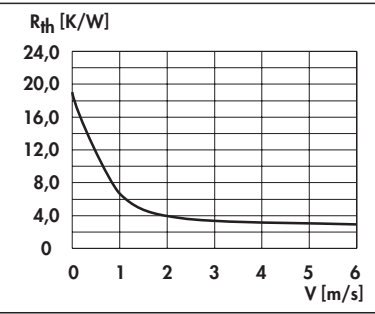
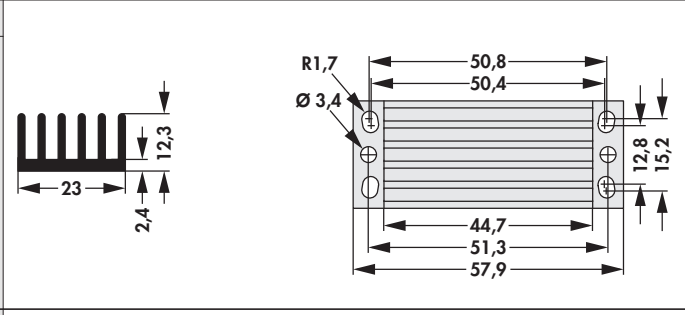
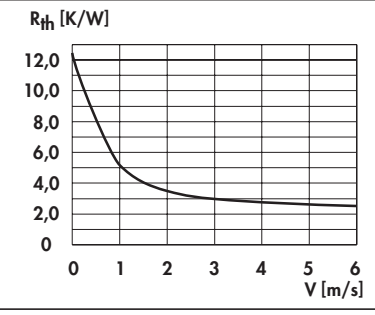
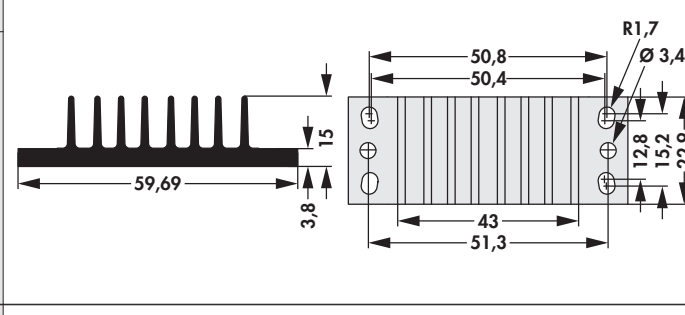
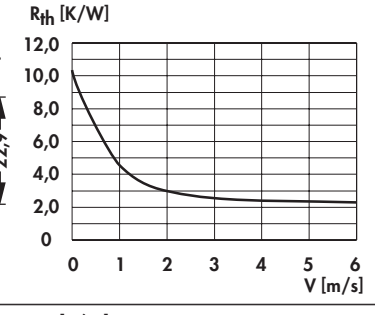
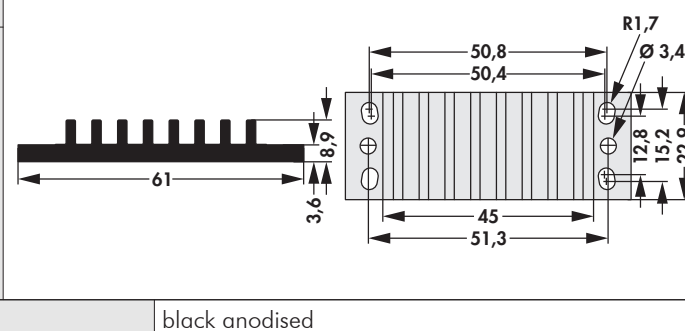
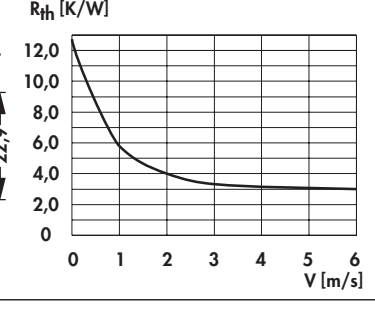
art. no. SK DC 15 58 SA		
art. no. SK DC 16 58 SA		
art. no. SK DC 17 58 SA		
art. no. SK DC 18 23 SA		
art. no. SK DC 19 23 SA		
surface:		black anodised

Retaining springs for transistors

art. no.	for transistor-housing	suitable for heatsinks	plate thickness [mm]	material	
THF 126 11	TO 126	-	2	stainless steel	
THF 126 12	TO 126	-	2	stainless steel	
THF 129 TO 220	TO 220	FK 219/ FK 222/ SK 129	1-2	stainless steel	
THF 220	TO 220	FK 219/ FK 222	1-2	stainless steel	
THF 220 15	TO 220	-	1.5-2.0	stainless steel	
THF 249	TO 220	FK 249	1.0-1.5	spring steel, corrosion protected	
THF 409 TO 220	TO 220/ TO 247/ TO 248/ TO 3 P	SK 409/ SK 181	1.5-3.0	stainless steel	
THF 409 220 2	TO 218/ TO 220/ TO 247/ TO 248/ TO 3 P	SK 145/ SK 185/ SK 437	4	stainless steel	
THF 409 SOT 32	TO 126/ SOT 32/ SOT 82	SK 409	2-3	stainless steel	
THF 220 17	TO 218/ TO 220/ TO 247/ TO 248/ TO 3 P	-	1.0-1.5	stainless steel	
THF 409 220 1	TO 218/ TO 220/ TO 247/ TO 248/ TO 3 P	SK 409/ SK 459	2-3	stainless steel	
THF 247	TO 220/ TO 247/ TO 248/ TO 3 P	SK 484	2	stainless steel	
THF 247 15	TO 247/ TO 248/ TO 3 P	SK 460	4	stainless steel	
THF 247 11	-	-	1.5	stainless steel	

B

C

D

E

F

G

H

I

K

L

M





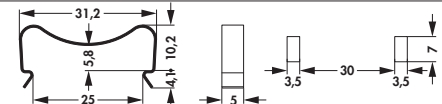
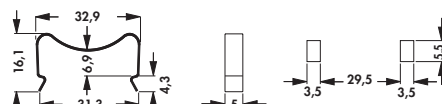
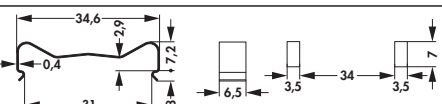
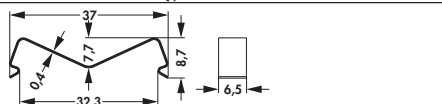
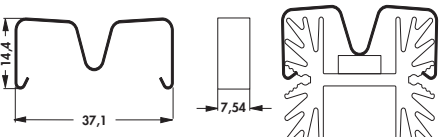
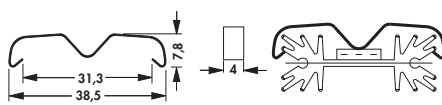

N

Retaining springs for transistors

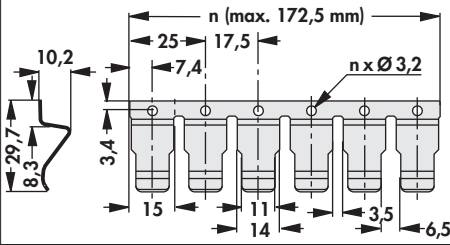
art. no.	for transistor-housing	suitable for heatsinks	plate thickness [mm]	material	
THF 247 14	TO 247/ TO 248/ TO 3 P	SK 484	2	stainless steel	
THF 247 4	TO 218/ TO 220/ TO 247/ TO 248/ TO 3 P	SK 460	4	stainless steel	
THF 220 35	2 x TO 220	-	1.0-1.5	stainless steel	
THF 126 37	TO 126	-	4	stainless steel	
THF 600	TO 218/ TO 220/ TO 247/ TO 3 P	SK 600	2.5	spring steel, corrosion protected	
THF 104	TO 220/ TO 247/ TO 248/ TO 3 P	SK 104	1-2	stainless steel	

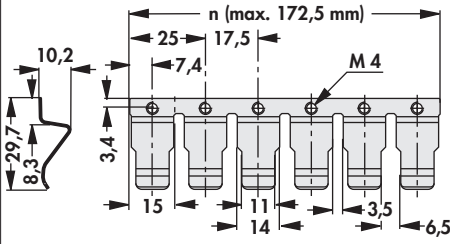
Retaining springs for transistors

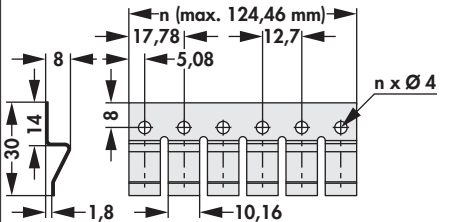
- universal **retaining spring** for transistor housings types TO 218, TO 220, TO 247, TO 264, SOT 32 and various SIP Multiwatt etc.
- fast and easy mounting of the transistors
- number of retaining spring elements can be chosen (**n = max. 10**)
- **THFMG** with thread M 4
- specific versions and modifications on customer's request

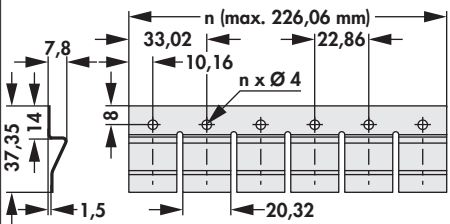
art. no.	for transistor-housing	spring force [N]	material		
THFM ...	TO 218/ TO 220/ TO 247/ TO 264/ SOT 32/ SIP Multiwatt	55 ±5	stainless steel		
THFMG ...	TO 218/ TO 220/ TO 247/ TO 264/ SOT 32/ SIP Multiwatt	55 ±5	stainless steel		
THFM 11 ...	TO 220	45 ±5	stainless steel		
THFM 20 ...	TO 247/ TO 264	70 ±5	stainless steel		
please indicate: ... number of retaining-spring elements					
1 - 10					

B

C

D

E

F

G

H

I

K

L

M





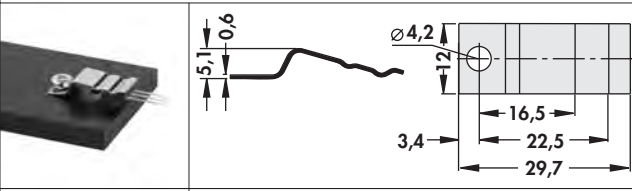
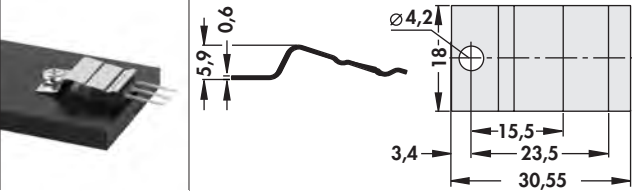
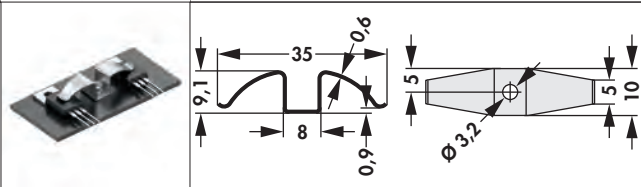

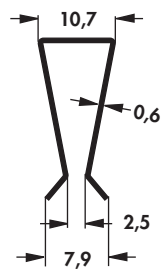
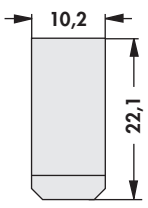

N

Retaining springs for transistors

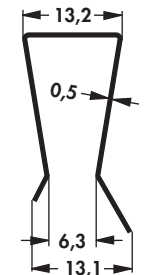
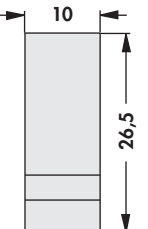
art. no.	for transistor-housing	spring force [N]	material	
THFK 220	TO 220	79	spring steel, corrosion protected	
THFK 247	TO 218/ TO 247	119	spring steel, corrosion protected	
THFK 36	TO 218/ TO 220/ TO 247/ TO 3 P	40	stainless steel	

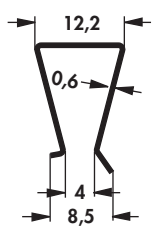
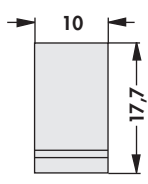
Retaining springs for transistors

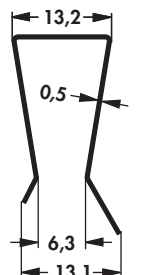
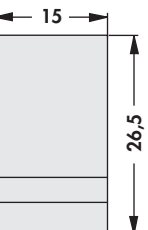
- able to slide on the transistor and mounting plate
- easy mounting
- high pressure force and firm grip
- specific versions upon customer's request

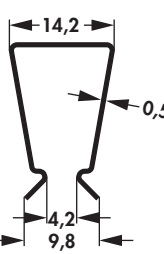
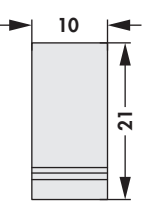
art. no.	for transistor-housing	plate thickness [mm]	holding force [N]	material			
THFA 1	TO 220	2	20	stainless steel			
THFA 2	TO 220	6.5	20	spring steel, corrosion protected			
THFA 3	TO 220	5.5	33	spring steel, corrosion protected			
THFA 4	TO 218/ TO 247	6.5	59	spring steel, corrosion protected			
THFA 5	TO 220/ TO 3 P	5	13	stainless steel			

B

C

D

E

F

G

H

I

K

L

M

N

Retaining springs for transistors

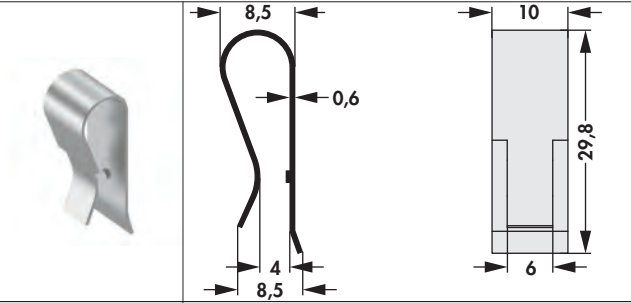
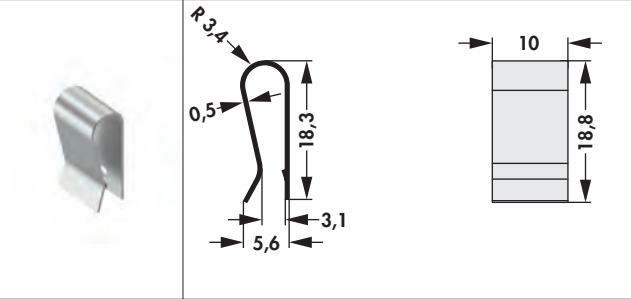
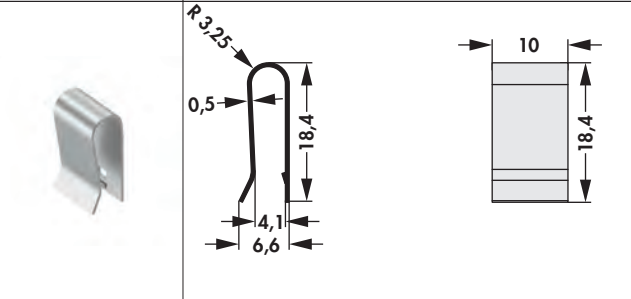
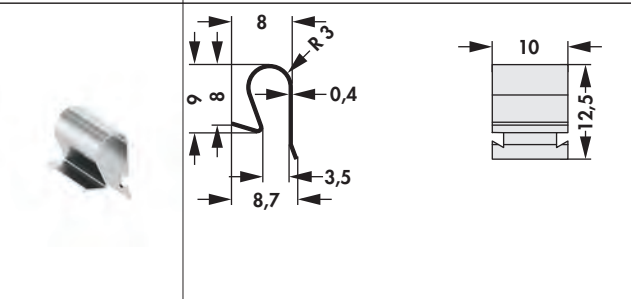
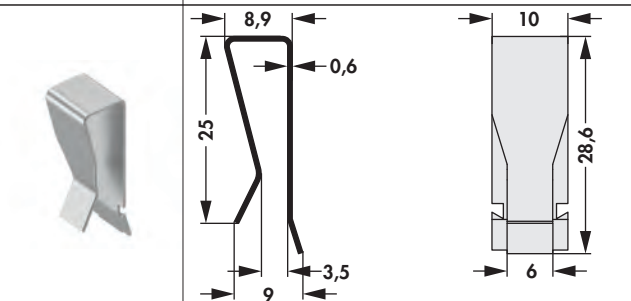
art. no.	for transistor-housing	plate thickness [mm]	holding force [N]	material	
THFA 6	TO 220/ TO 3 P	3	28	spring steel, corrosion protected	
THFA 7	TO 220/ TO 3 P	3	50	spring steel, corrosion protected	
THFA 8	TO 220/ TO 3 P	3	55	spring steel, corrosion protected	
THFA 9	TO 220/ TO 3 P	1	20	stainless steel	
THFA 10	TO 220/ TO 3 P	4	32	spring steel, corrosion protected	

Retaining springs for transistors

- **universal lock-in retaining spring** for types TO 218, TO 220, TO 247, TO 264 and various SIP-Multiwatt etc. transistor housings
- clip fastening also for power transistors without holes, MAX types etc.
- easy assembly and secure hold when using a special groove geometry in heatsinks, housing parts etc.
- optimal heat transfer between component and cooling element
- various spring clip shapes available for fastening the components (see sketch)
- the indicated spring forces **THFU 1-7** refer to a transistor thickness of 4.5 mm (TO 220)
- the range of suitable heat sinks is continuously extended
- versions specifically designed to meet customers requirements on request

Installation

THFU 1

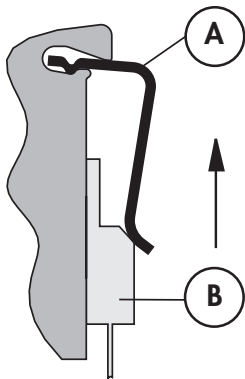

- **insert** the lock-in retaining spring for transistors THFU 1 (A) into the groove of the profile
- **push** transistor (B) below the spring in

THFU 2, THFU 3, THFU 4, THFU 5, THFU 6, THFU 7

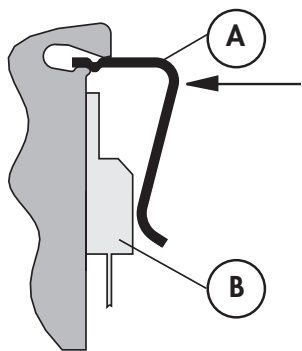

- **place** transistor (B) onto the mounting area
- **press** the lock-in retaining spring for transistors THFU 2 - 7 (A) into the groove of the profile (a suitable installation aid will facilitate pressing in)

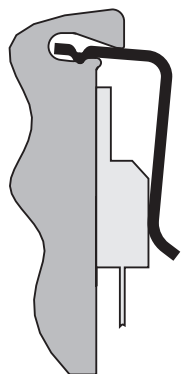

- Once in place, the spring will keep its position and fix the transistor with a high contact pressure on the installation surface (the spring remains in its position and it can neither be moved in a lengthwise direction nor fall it can out of the groove in a cross direction).

material:	stainless steel
material thickness:	0.8 mm

Lock-in retaining spring for transistors

B

C

D

E

F

G

H

I

K

L

M

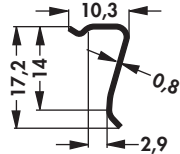
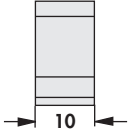
art. no.	for transistor-housing	suitable for heatsinks	spring force [N]	material	
THFU 1	TO 218/ TO 220/ TO 247/ TO 262/ TO 3 P/ SOT 199/ SOT 429	SK 480/ SK 481/ SK 482/ SK 483/ SK 487/ SK 489/ SK 490/ SK 492/ SK 495/ SK 499/ SK 512/ SK 514/ SK 573/ SK 574/ SK 575/ SK 576/ SK 589/ SK 593/ SK 617/ SK 637/ SK 638/ SK 181/ SK 640/ SK 641/ SK 662/ SK 664/ SK 665/ SK 669/ SK 681/ SK 697/ SK 701/ SK 702/ SK 703/ SK 704/ SK 705/ LAM 3 K/ LAM 3 D K/ LAM 4 K/ LAM 4 D K/ LAM 5 K/ LAM 5 D K/ LAM 6 K/ LAM 6 D K/ LAM 7 K/ LA 27 K	60 ±5	stainless steel	  

Lock-in retaining spring for transistors

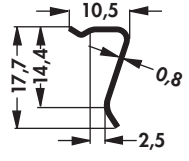
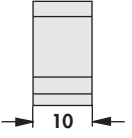
art. no.	for transistor-housing	suitable for heatsinks	spring force [N]	material	
THFU 2	TO 218/ TO 220/ TO 247/ TO 262/ TO 3 P/ SOT 199/ SOT 429	SK 480/ SK 481/ SK 482/ SK 483/ SK 487/ SK 489/ SK 490/ SK 492/ SK 495/ SK 499/ SK 512/ SK 514/ SK 573/ SK 574/ SK 575/ SK 576/ SK 589/ SK 593/ SK 617/ SK 637/ SK 638/ SK 181/ SK 640/ SK 641/ SK 662/ SK 664/ SK 665/ SK 669/ SK 681/ SK 697/ SK 701/ SK 702/ SK 703/ SK 704/ SK 705/ LAM 3 K/ LAM 3 D K/ LAM 4 K/ LAM 4 D K/ LAM 5 K/ LAM 5 D K/ LAM 6 K/ LAM 6 D K/ LAM 7 K/ LA 27 K	60 ±5	stainless steel	  

B

C

D

E

F

G

H

I

K

L

M

Lock-in retaining spring for transistors

B

C

D

E

F

G

H

I

K



L

M

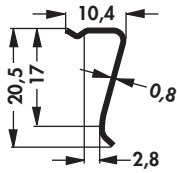
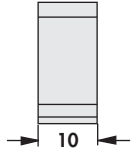
N

art. no.	for transistor-housing	suitable for heatsinks	spring force [N]	material			
THFU 3	TO 218/ TO 220/ TO 247/ TO 262/ TO 3 P/ SOT 199/ SOT 429	SK 480/ SK 481/ SK 482/ SK 483/ SK 487/ SK 489/ SK 490/ SK 492/ SK 495/ SK 499/ SK 514/ SK 573/ SK 574/ SK 575/ SK 576/ SK 589/ SK 593/ SK 617/ SK 637/ SK 638/ SK 181/ SK 640/ SK 641/ SK 662/ SK 664/ SK 665/ SK 669/ SK 681/ SK 697/ SK 701/ SK 702/ SK 703/ SK 704/ SK 705/ LAM 3 K/ LAM 3 D K/ LAM 4 K/ LAM 4 D K/ LAM 5 K/ LAM 5 D K/ LAM 6 K/ LAM 6 D K/ LAM 7 K/ LA 27 K	50 ±5	stainless steel			

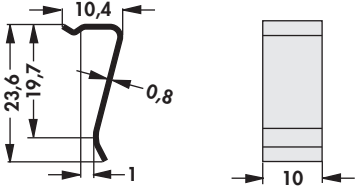
Lock-in retaining spring for transistors

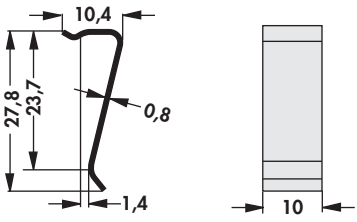
art. no.	for transistor-housing	suitable for heatsinks	spring force [N]	material		
THFU 4	TO 218/ TO 202/ TO 220/ TO 248/ TO 262/ TO 264/ TO 3 P/ SOT 199	SK 480/ SK 481/ SK 482/ SK 483/ SK 487/ SK 489/ SK 490/ SK 495/ SK 499/ SK 514/ SK 575/ SK 589/ SK 593/ SK 617/ SK 638/ SK 181/ SK 640/ SK 641/ SK 662/ SK 664/ SK 665/ SK 669/ SK 681/ SK 697/ SK 702/ SK 703/ SK 704/ SK 705/ LAM 5 K/ LAM 5 D K/ LAM 6 K/ LAM 6 D K/ LA 27 K	32 ±5	stainless steel		
THFU 5	TO 218/ TO 202/ TO 220/ TO 247/ TO 248/ TO 262/ TO 264/ TO 3 P/ SOT 199/ SOT 429	SK 490/ SK 589/ SK 617/ SK 181/ SK 662/ SK 664/ SK 665/ SK 669/ LAM 5 K/ LAM 5 D K/ LAM 6 K/ LAM 6 D K/ LAM 7 K/ LA 27 K	25 ±5	stainless steel		

B

C

D

E

F

G

H

I

K

L

M

N

Lock-in retaining spring for transistors

B

C

D

E

F

G

H

I

K

L

M

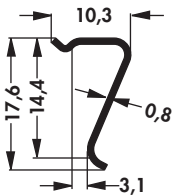
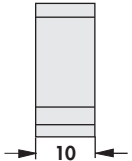
art. no.	for transistor-housing	suitable for heatsinks	spring force [N]	material	
THFU 6	TO 126/ TO 218/ TO 220/ TO 225/ TO 247/ TO 248/ TO 251/ TO 3 P/ SOT 32	SK 480/ SK 481/ SK 482/ SK 483/ SK 487/ SK 489/ SK 490/ SK 492/ SK 495/ SK 499/ SK 512/ SK 514/ SK 573/ SK 574/ SK 575/ SK 576/ SK 589/ SK 593/ SK 617/ SK 637/ SK 638/ SK 181/ SK 640/ SK 641/ SK 662/ SK 664/ SK 665/ SK 669/ SK 681/ SK 697/ SK 701/ SK 702/ SK 703/ SK 704/ SK 705/ LAM 3 K/ LAM 3 D K/ LAM 4 K/ LAM 4 D K/ LAM 5 K/ LAM 5 D K/ LAM 6 K/ LAM 6 D K/ LAM 7 K/ LA 27 K	65 ±5	stainless steel	  

Lock-in retaining spring for transistors

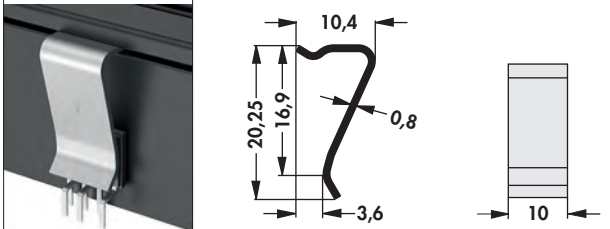
art. no.	for transistor-housing	suitable for heatsinks	spring force [N]	material	
THFU 7	eSIP	SK 480/ SK 482/ SK 483/ SK 487/ SK 490/ SK 492/ SK 495/ SK 573/ SK 574/ SK 576/ SK 637/ SK 638/ SK 681/ SK 697/ SK 701/ LAM 3 K/ LAM 3 D K/ LAM 6 K/ LAM 6 D K/ LAM 7 K	40 ±5	stainless steel	

B

C

D

E

F

G

H

I







K

L

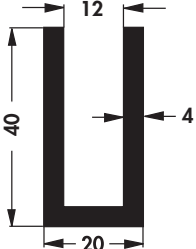
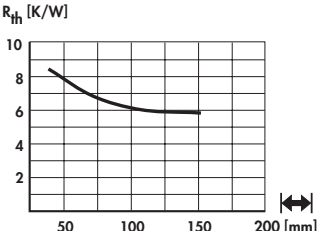
M

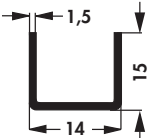
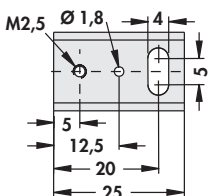
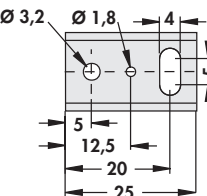
N

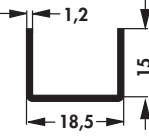
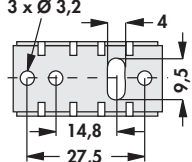
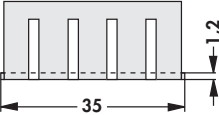
U-Extruded heatsinks

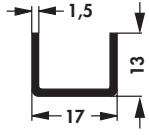
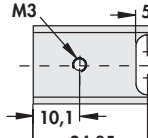
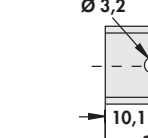
art. no. SK 115 ...			
please indicate: ...  37.5 50 1000 mm			
	<div style="display: flex; justify-content: space-around;"> <div style="text-align: center;"> UK 14 SA 220  </div> <div style="text-align: center;"> UK 14 SA 220 3,2  </div> <div style="text-align: center;"> UK 14 SA M3  </div> </div>		
art. no. UK 14 SA 220 UK 14 SA 220 3,2 UK 14 SA M3	R_{th} [K/W] 20		Φ TO 220
	<div style="display: flex; justify-content: space-around;"> <div style="text-align: center;">  </div> <div style="text-align: center;">  </div> <div style="text-align: center;">  </div> </div>		
art. no. ICK 35 SA	R_{th} [K/W] 15		Φ TO 220
	<div style="display: flex; justify-content: space-around;"> <div style="text-align: center;"> SK 13 35 SA 220  </div> <div style="text-align: center;"> SK 13 35 SA 220 3,2  </div> <div style="text-align: center;"> SK 13 35 SA 220 3,5  </div> </div>		
art. no. SK 13 35 SA 220 SK 13 35 SA 220 3,2 SK 13 35 SA 220 3,5	R_{th} [K/W] 17		Φ TO 220
surface:		black anodised	

U-Extruded heatsinks

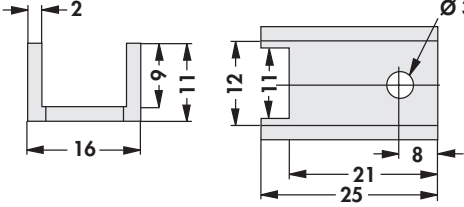
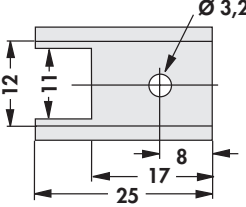
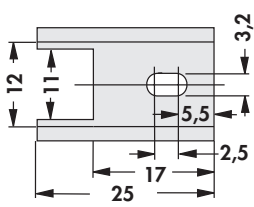
	<p>SK 431 1</p> 	<p>SK 431 2</p> 	<p>SK 431 3</p> 
<p>art. no.</p>	<p>R_{th} [K/W]</p>	<p>☐</p>	
<p>SK 431 1</p>	<p>18</p>	<p>TO 220</p>	
<p>SK 431 2</p>	<p>18</p>	<p>TO 220</p>	
<p>SK 431 3</p>	<p>18</p>	<p>TO 220</p>	
<p>surface:</p>	<p>black anodised</p>		

B

C

D

E

F

G

H

I

K

L

M

Attachable heatsinks and angle for TO 3



B

C

D

E

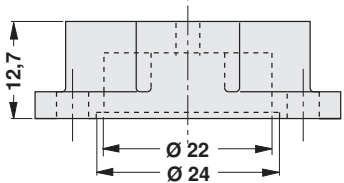
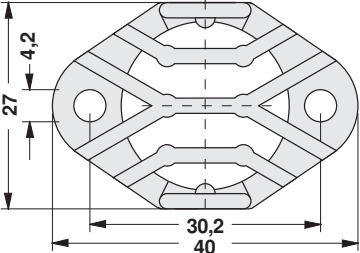
F

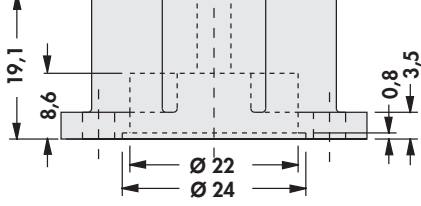
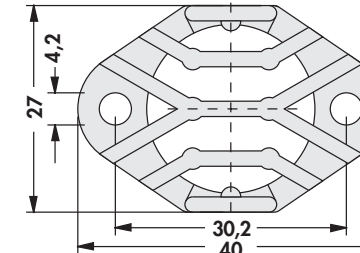
		
art. no.	[mm]	R_{th} [K/W]
AKK 127	27	14
		
art. no.	[mm]	R_{th} [K/W]
AKK 191	27	12
surface:	black lacquered	
material:	die-casting aluminium	

G

H

I

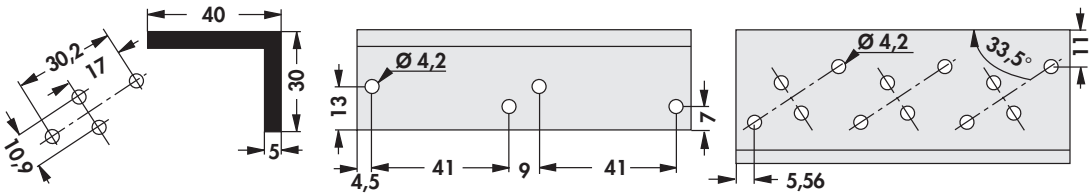
			
art. no.	[mm]	R_{th} [K/W]	☎
WP 4030 100 ...	100	3.7	—
WP 4030 100 3 ...			TO 3
<p>please indicate: ... surface</p> <p>SA = black anodised</p> <p>AL = aluminium natural/degreased/cutting edges not deburred (by the metre not degreased/cutting edges not deburred)</p>			

K

L

M

N

Die-cast heatsinks

Die-cast acc. to german standard DIN 41882

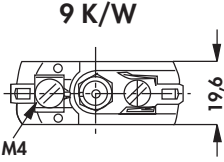
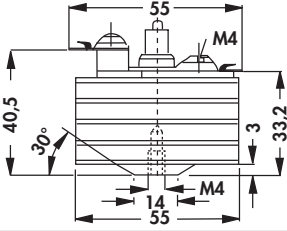

<p>art. no.</p> <p>K 9 M 4</p>		<p>9 K/W</p> 	
<p>surface:</p>		<p>black lacquered</p>	

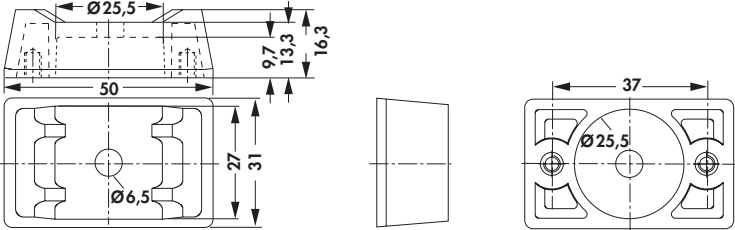
Mounting parts for heatsinks

<p>art. no.</p> <p>IS 53</p>			
-------------------------------------	--	--	--

Die-cast heatsinks

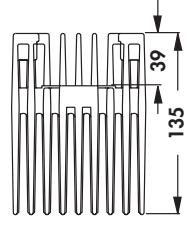
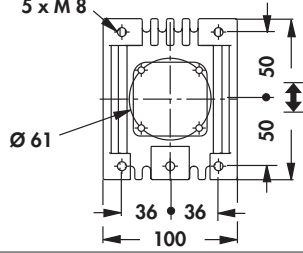
- completely milled mounting surface for semiconductors with square bottom plates
- the mounting surface can be equipped with threads for fastening semiconductors with screwed glands (semiconductor thread tapping)
- threads from M 4 to M 32 x 1.5 or 4 x threads for semiconductors with clamping plate mounting are available on request
- strap fastening thread M 8
- delivery without anode strap
- other lengths and drillings on request

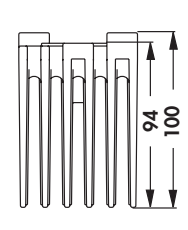
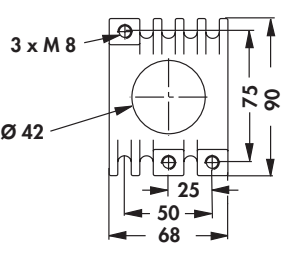
	0,55 K/W		
art. no.	K [mm]	R_{th} [K/W]	
K 0,55 M 12	120	0.55	
	1,1 K/W		
art. no.	K [mm]	R_{th} [K/W]	
K 1,1 M 12	90	1.1	
surface:	black lacquered		

Accessories

- anode end strap made of tin-plated cathode copper

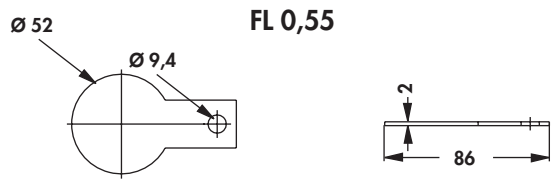
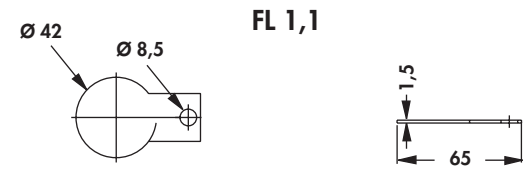
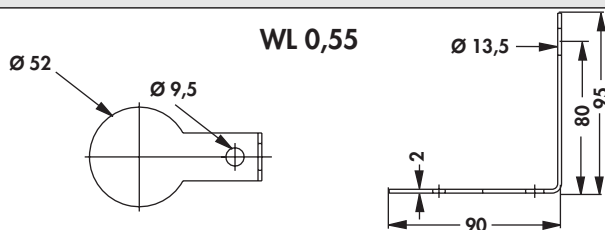
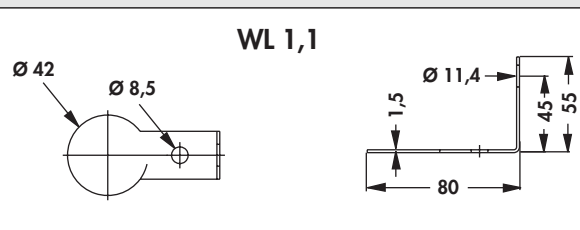
	FL 0,55		FL 1,1
art. no.	FL 0,55	art. no.	FL 1,1
	WL 0,55		WL 1,1
art. no.	WL 0,55	art. no.	WL 1,1

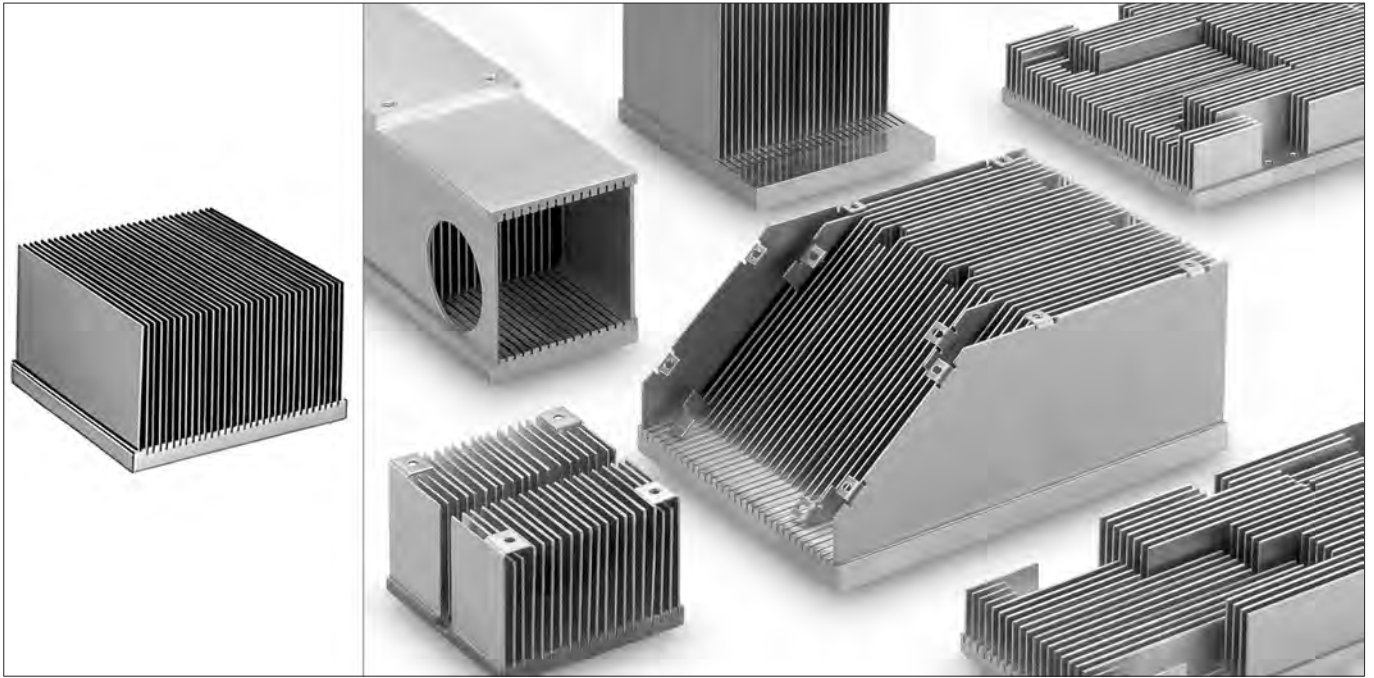

- fin coolers in special design
- especially suitable for thermoelectric elements (Peltier-elements) and similar power modules
- compact design with reduced volume
- large surface, therefore more efficient than extruded profiles
- particularly low thermal resistance with forced fan cooling
- thermally optimised fins pressed into the base profile additionally fixed with thermally conductive adhesive to avoid air pockets
- accurately flat milled surfaces
- very low roughness
- machining for module mounting according to drawing
- heat bridges (spacing bridges) on request
- lapped surface on request
- customer specific special design

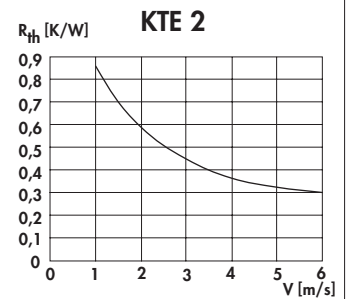
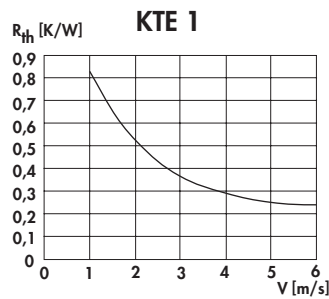
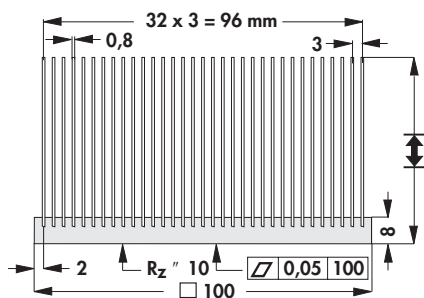

art. no.	∓ [mm]	art. no.	∓ [mm]
KTE 1	58	KTE 2	46
material:		aluminium, construction with copper on request	

KTE

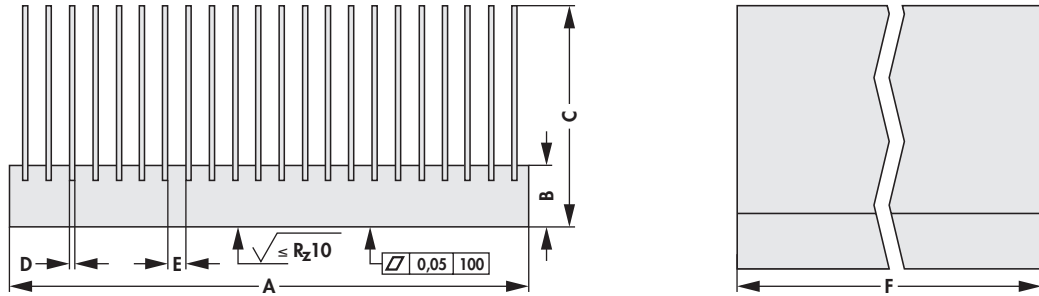

possible dimensions:

dimensions [mm]						
A	B	C	D	E	F	
max. 400	max. 30	max. 150	0.8 / 1 / 1.5 / 2	min. 2	max. 400	

please indicate with your order:

dimensions [mm]						
A	B	C	D	E	F	
material:		aluminium, construction with copper upon request				

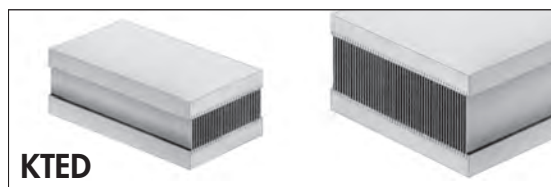

KTED

- fin coolers in special design
- for forced convection, thus particularly low thermal resistance
- two opposite bottom plates as mounting surfaces for power modules and similar
- mounting surfaces precisely flat milled
- compact design with reduced volume
- ideally fitted thermotechnical and in the basic material pressed in lamellas are additionally mounted with thermal conductive glues to avoid air pockets
- lapped finish on request
- additional machining according to customer's requirements
- fan versions on request
- special constructions to customer's indications

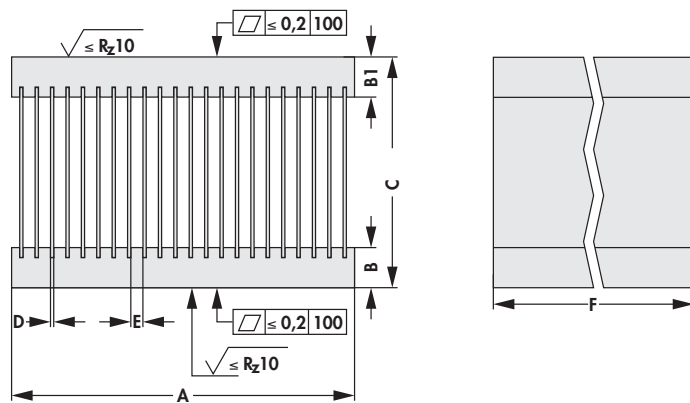

possible dimensions:

dimensions [mm]						
A	B	B 1	C	D	E	F
max. 400	max. 30	max. 30	max. 150	0.8 / 1 / 1.5 / 2	min. 2	max. 400

please indicate with your order:

dimensions [mm]						
A	B	B 1	C	D	E	F
max. 400	max. 30	max. 30	max. 150	0.8 / 1 / 1.5 / 2	min. 2	max. 400
material:		aluminium, construction with copper upon request				

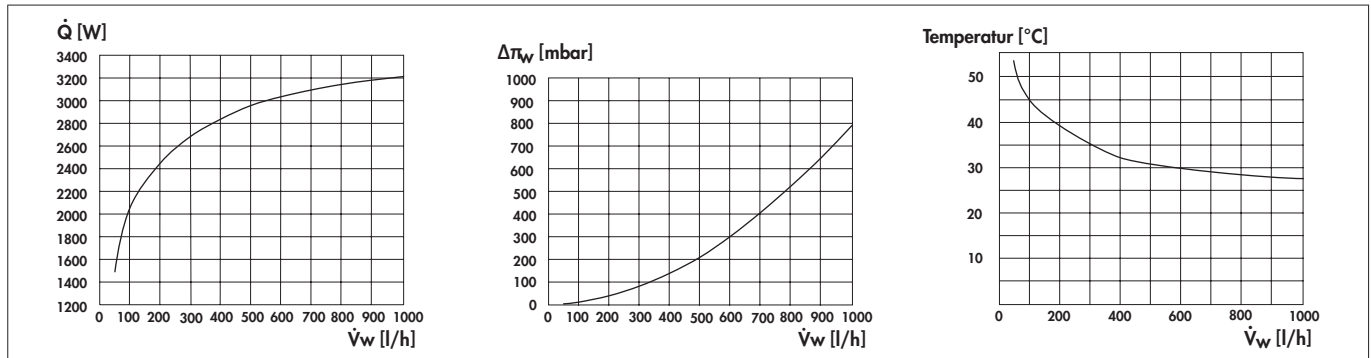

– water glycol mixture (60/40); inlet temperature approx. 26 °C

Liquid coolers of special design for high-power converters PrimePack™3+ module (IGBT 5); **for heat dissipation of maximum 3 modules on one liquid cooler**; suitable for water pH 6,5-8,5 with corrosion protection as well as other fluids (i.e. oils, alcohols, etc.); **particularly good heat transfer to the fluid by means of inner lamellae structure**; operating excess pressure up to 2 bars possible; **thick mounting plate for optimal heat distribution**; mounting of the modules will be done by already installed M5 threads; **threw holes for mounting of the fluid coolers**; precisely milled flat semiconductor mounting surface with very good flatness and low roughness depth; **line connection for water inlet and outlet by means of a G 3/4" thread**; special designs and modifications for a specific assembly situation according to customerspecific specifications.

To avoid corrosion in the water cooler the cooling fluid has to flow in a closed circuit and it has to contain 40-60 % (preferred is 50 %) anti-corrosive fluids for aluminium, if necessary with anti-freeze. For the choice and approval of the cooling fluid as well as for the possible consequences in the cooling circuit the user is the only liable person. Therefore we exclude any liability for damages caused by the choice or approval of the cooling fluids.

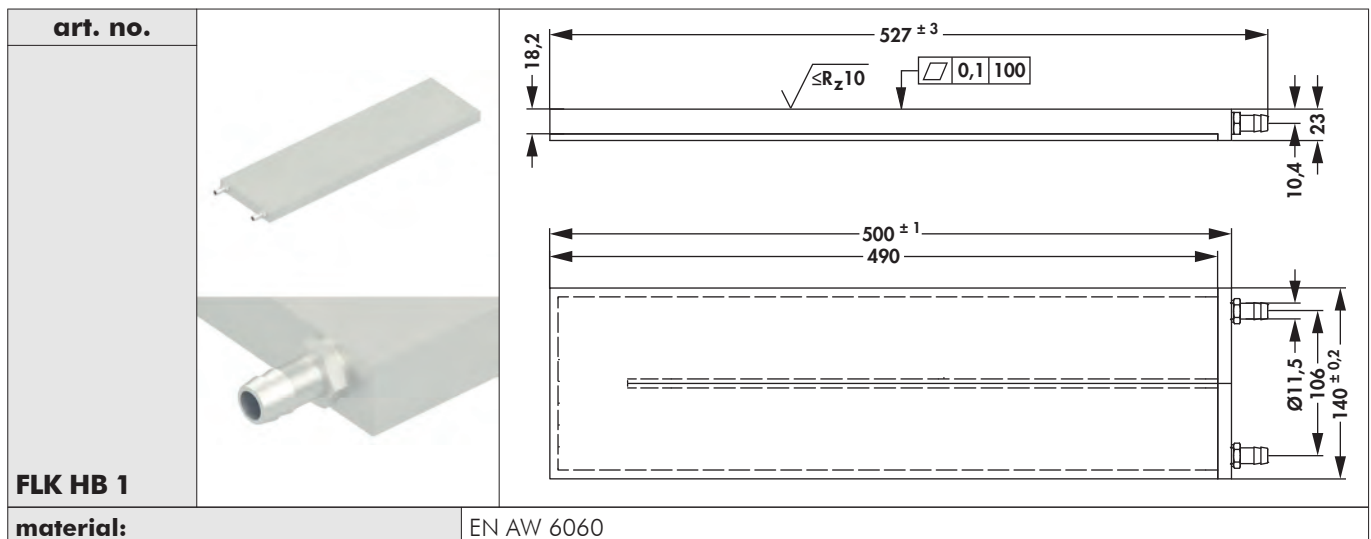

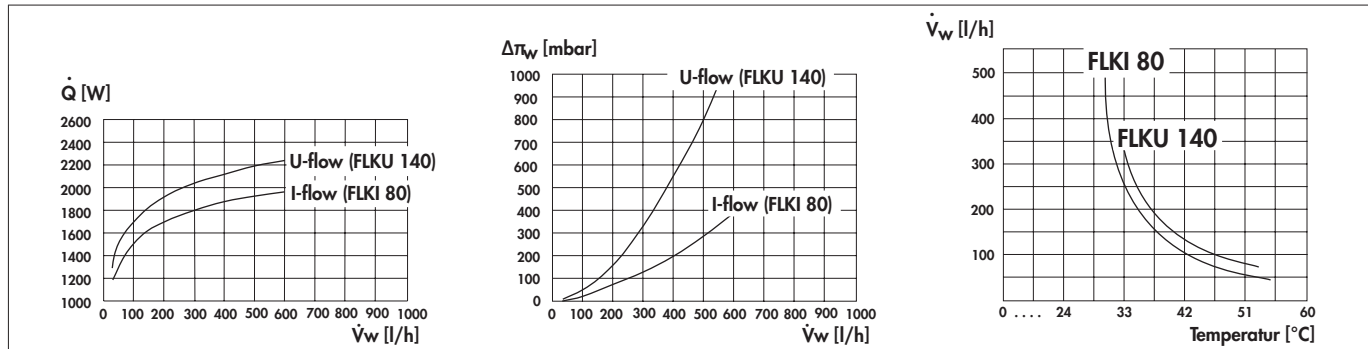



– water-glycol mixture (60/40); inlet temperature approx. 26 °C

Fluid cooler for dissipating large quantities of heat with low space requirement; **effective system to cool power modules**; suitable for water pH 6.5-8.5 with anticorrosives, as well as other fluids (eg. oil, alcohols, etc.); **compact design with internal fin structure for particularly good heat transfer to the fluid**; minimised flow pressure losses (see diagram); **operating pressure up to 2 bar possible**; thick base plate for optimum heat distribution and to secure the heat-emitting elements; **mounting flange for the cooler according to customer's instructions**; precisely face milled surface of component mounting area with very good flatness and low roughness depth; **dimensionally accurate adjustment to given mounting conditions**; connections using hole ports 12 mm in diameter with reinforcing seam to DIN 71550 or installation flange to customer's instructions; **I- or U-throughflow or multiple throughflow versions**; max. drilling depth in the base plate: 7 mm

To avoid corrosion in the water cooler the cooling fluid has to flow in a closed circuit and it has to contain 40-60 % (preferred is 50 %) anti-corrosive fluids for aluminium, if necessary with anti-freeze. For the choice and approval of the cooling fluid as well as for the possible consequences in the cooling circuit the user is the only liable person. Therefore we exclude any liability for damages caused by the choice or approval of the cooling fluids.

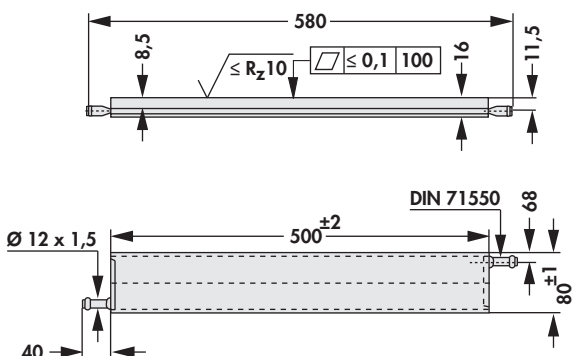
– dimensions and designs using customer's instructions

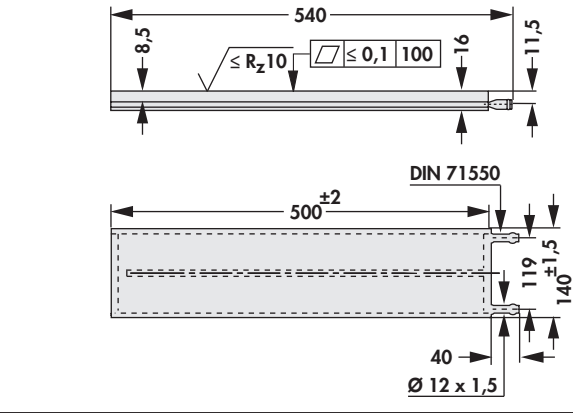
<p>art. no.</p>  <p>FLKI 80</p>	
<p>art. no.</p>  <p>FLKU 140</p>	
<p>material: EN AW 6060</p>	

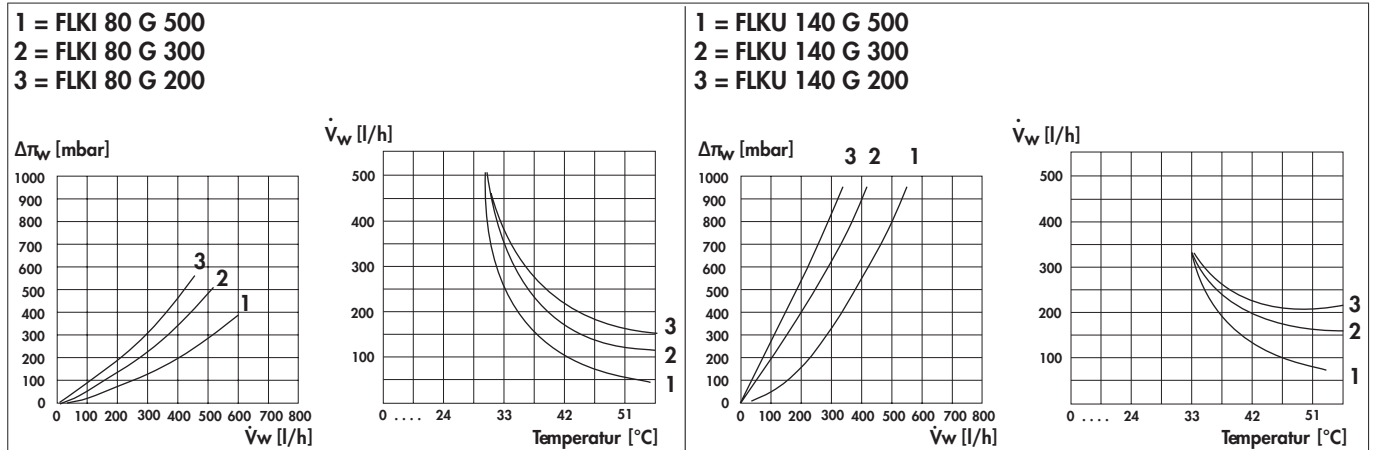

– water-glycol mixture (60/40); inlet temperature approx. 26 °C

Fluid cooler for dissipating large quantities of heat with low space requirement; **effective system to cool power modules**; suitable for water pH 6.5-8.5 with anticorrosive, as well as other fluids (eg. oil, alcohols, etc.); **compact design with internal fin structure for particularly good heat transfer to the fluid**; minimised flow pressure losses; **operating pressure up to 2 bar possible**; thick base plate for optimum heat distribution and to secure the heat-emitting elements; **mounting flange for the cooler according to customer's instructions**; precisely face milled surface of component mounting area with very good evenness and low roughness depth; **for power modules like IGBT-module, Thyristor-module, SCR diode module, bridge amplifiers and others**; dimensionally accurate adjustment to given mounting conditions; **connctions with thread muffle 1/8" or mounting flange according to customer's instructions**; I- or U-throughflow or multiple throughflow versions; **max. drilling depth in the base plate: 17 mm**

To avoid corrosion in the water cooler the cooling fluid has to flow in a closed circuit and it has to contain 40-60 % (preferred is 50 %) anti-corrosive fluids for aluminium, if necessary with anti-freeze. For the choice and approval of the cooling fluid as well as for the possible consequences in the cooling circuit the user is the only liable person. Therefore we exclude any liability for damages caused by the choice or approval of the cooling fluids.

– dimensions and designs using customer's instructions

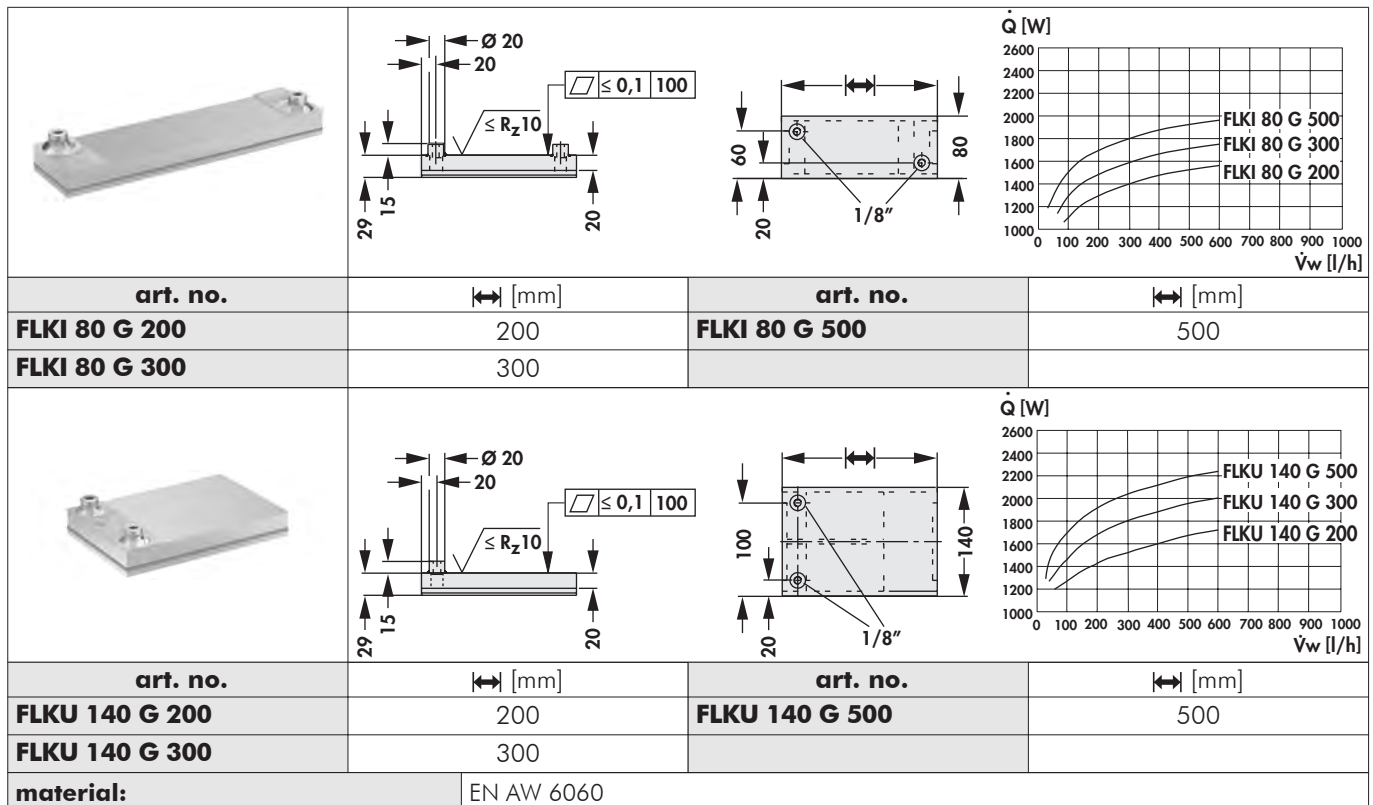

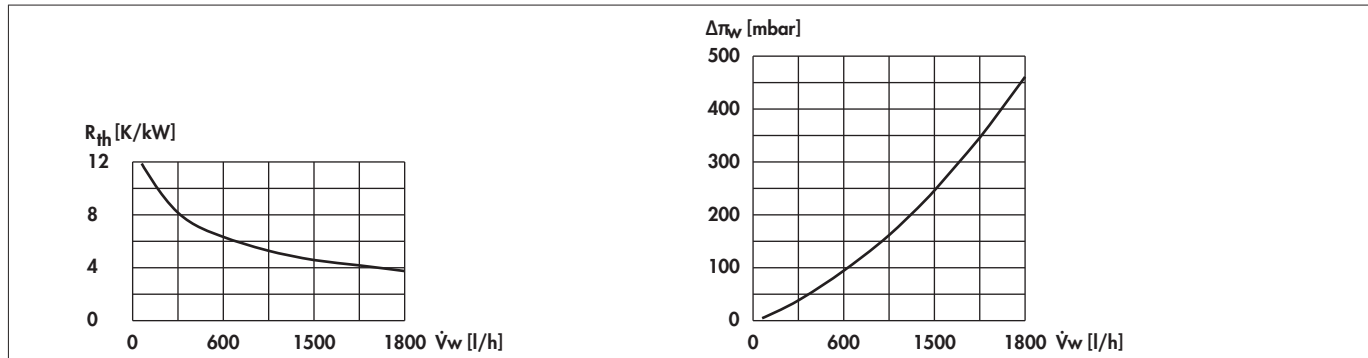

– water glycol mixture (60/40); inlet temperature approx. 26 °C

Liquid coolers of special design for high-power converters PrimePack™3+ module (IGBT 5); **for heat dissipation of maximum 3 modules on one liquid cooler**; suitable for water pH 6,5-8,5 with corrosion protection as well as other fluids (i.e. oils, alcohols, etc.); **particularly good heat transfer to the fluid by means of inner lamellae structure**; operating excess pressure up to 2 bars possible; **thick mounting plate for optimal heat distribution**; mounting of the modules will be done by already installed M5 threads; **threw holes for mounting of the fluid coolers**; precisely milled flat semiconductor mounting surface with very good flatness and low roughness depth; **line connection for water inlet and outlet by means of a G 3/4" thread**; special designs and modifications for a specific assembly situation according to customerspecific specifications.

To avoid corrosion in the water cooler the cooling fluid has to flow in a closed circuit and it has to contain 40-60 % (preferred is 50 %) anti-corrosive fluids for aluminium, if necessary with anti-freeze. For the choice and approval of the cooling fluid as well as for the possible consequences in the cooling circuit the user is the only liable person. Therefore we exclude any liability for damages caused by the choice or approval of the cooling fluids.

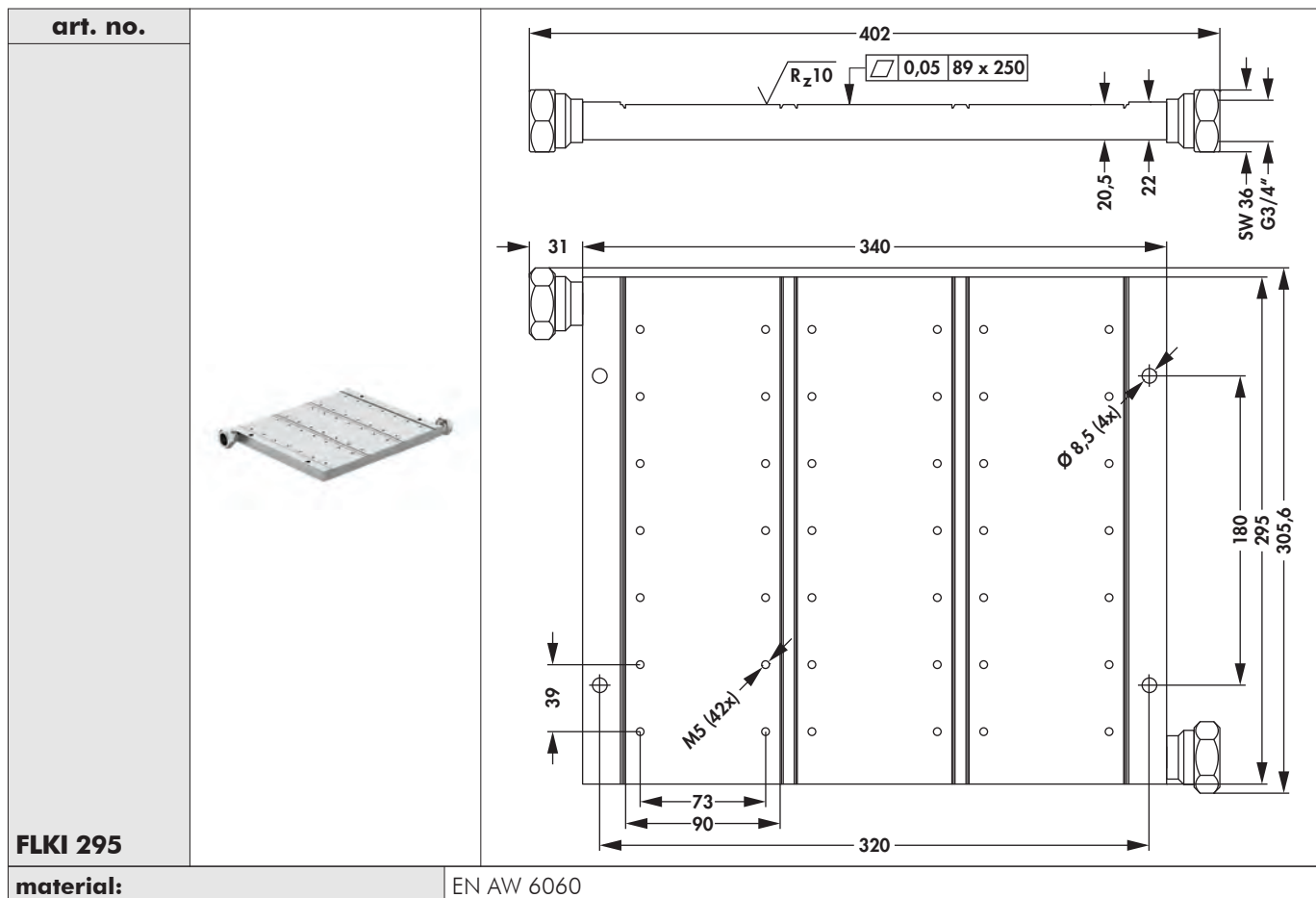

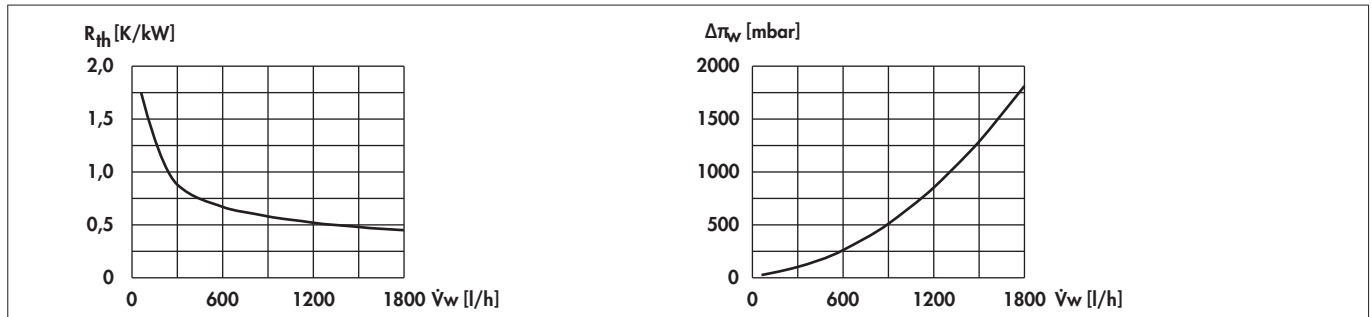

– water glycol mixture (60/40); inlet temperature approx. 26 °C

Fluid cooler for dissipating large quantities of heat with low space requirement; **effective system to cool power modules**; suitable for water pH 6,5-8,5 with anticorrosives, as well as other fluids (eg. oils, alcohols, etc.); **compact design with internal fin structure for particularly good heat transfer to the fluid**; minimised flow pressure losses; **operating excess pressure up to 2 bar possible**; thick base plate for optimum heat distribution and to secure the heat-emitting elements; **mounting flange for the cooler according to customer's instructions**; precisely face milled surface of the component mounting area with very good flatness and low roughness depth; **for power modules such as IGBT-modules, thyristor-modules, SCR diode modules, bridge amplifier and others; dimensional modification at specified installation conditions**; connections via thread G3/4" or mounting flange according to customer's specifications; **drilling depth into the base panel maximum 17 mm.**

To avoid corrosion in the water cooler the cooling fluid has to flow in a closed circuit and it has to contain 40-60 % (preferred is 50 %) anti-corrosive fluids for aluminium, if necessary with anti-freeze. For the choice and approval of the cooling fluid as well as for the possible consequences in the cooling circuit the user is the only liable person. Therefore we exclude any liability for damages caused by the choice or approval of the cooling fluids.

– Dimensioning and realisation in connection with customer's specifications

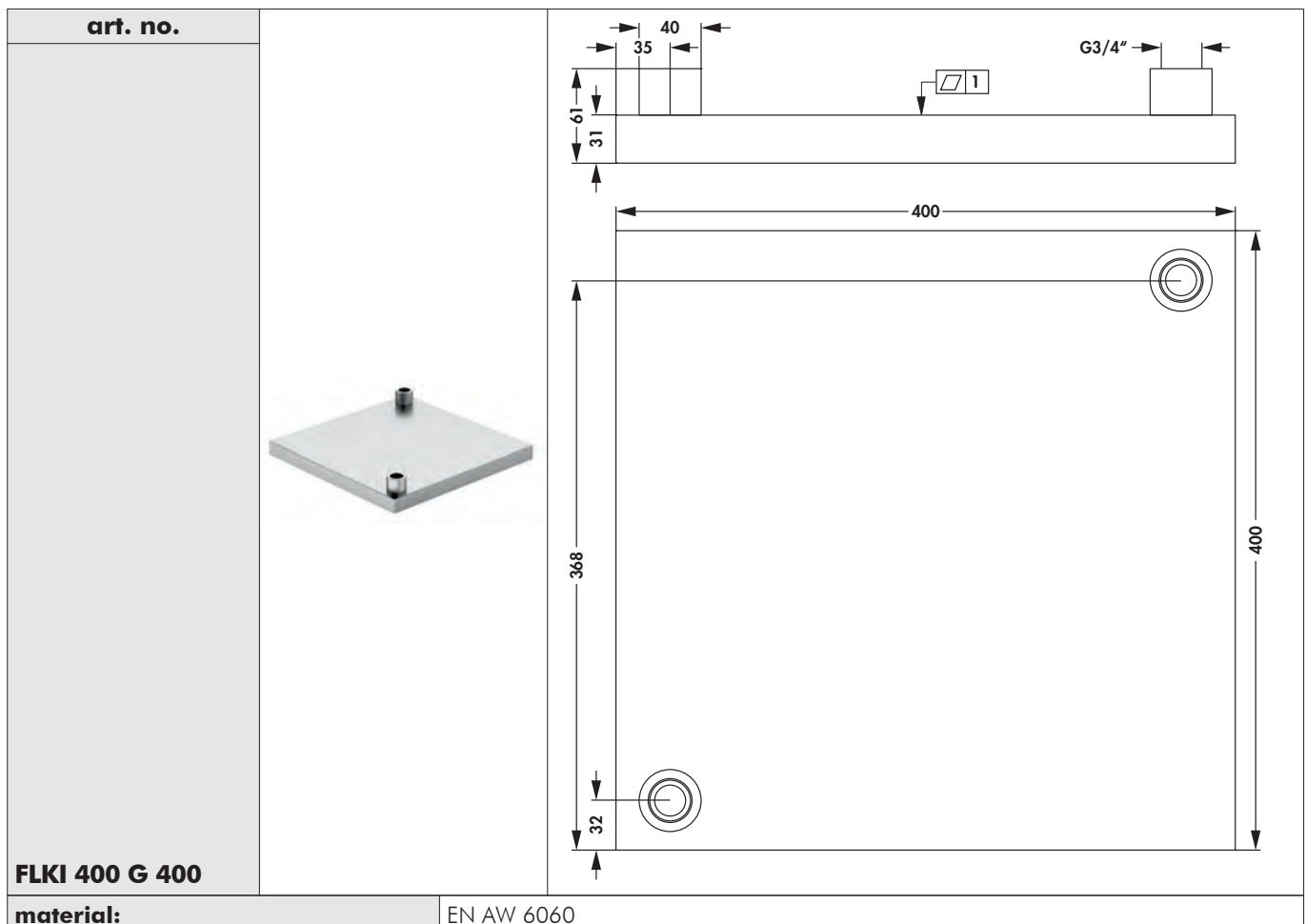

Recooling systems for liquid coolers

- recooling system for all types of liquid coolers
- cools up to 2,600 watts thermal power loss
- consists of pump and recooling
- pump as normally aspirating, single-stage centrifugal pump with spiral housing in block construction
- recooling with liquid-conducting tube system with air lamella and electrically driven fan motor
- further information free of charge under: **FLK R1-Info**
- notes: anticorrosive agents are required when water is used as coolant (eg. water/glykol - 60/40)
- the hose systems used (NOT in scope of delivery) must be resistant to anticorrosive agents (eg. material EPDM according to DIN 73411, ISO 4081)

To avoid corrosion in the water cooler the cooling fluid has to flow in a closed circuit and it has to contain 40-60% (preferred is 50%) anti-corrosive fluids for aluminium, if necessary with anti-freeze. For the choice and approval of the cooling fluid as well as for the possible consequences in the cooling circuit the user is the only liable person. Therefore we exclude any liability for damages caused by the choice or approval of the cooling fluids.

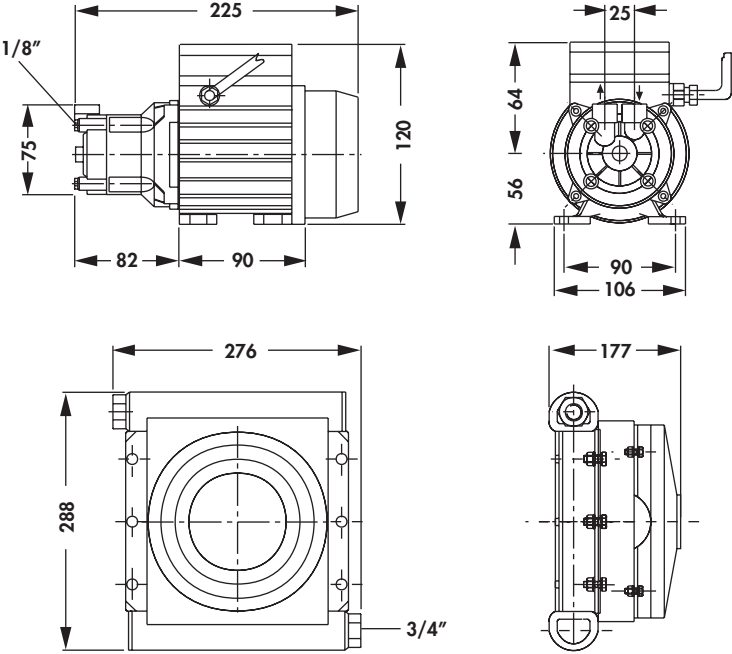
art. no.		
FLKR 1		
thermal cooling capacity:	max. 2.600 W	
pump:	single-phase 230 V AC, 120 W	
recooler:	single-phase 230 V AC, 120 W/ three-phase 400 V AC, 90 W	
type of delivery:	pump and recooling	

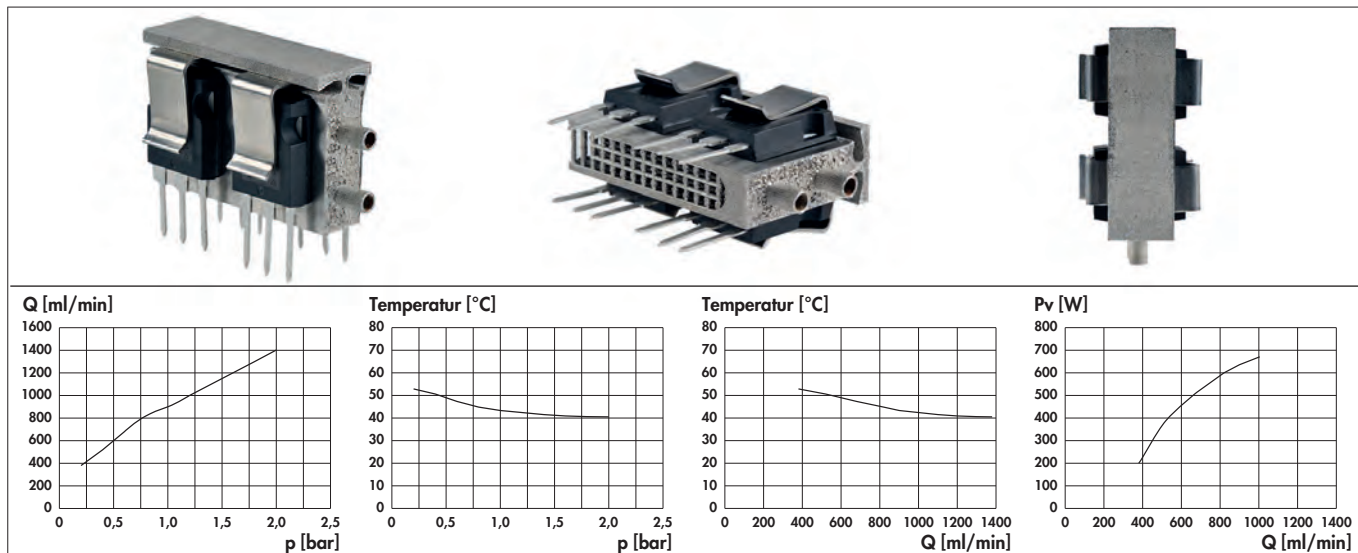

- technical data refer to a water inlet temperature of 23 °C
- stainless austenitic steel / 1.4404 stainless steel V4A
- water as a cooling medium without corrosion protection inhibitors
- suitable liquid pumps and hose systems on request
- other materials with higher thermal conductivity (nickel) on request
- version with soldering for PCB mounting on request
- customer-specific adaptations and designs

Liquid coolers for circuit board assembly; **produced in 3D printing with an AI-optimized heat exchange structure**; dissipation of large amounts of heat with little space requirement; **particularly suitable for power semiconductors in TO case, SIP Multiwatt and similar**; simple and safe component assembly using lock-in retaining springs for transistors from the THFU series; **separate cooling circuit on each mounting side**; minimized flow pressure losses through optimized heat exchange structure; **finely ground semiconductor mounting surfaces with very good flatness and low surface roughness**; maximum operating pressure up to 3 bar; **max. dissipated power loss with a difference in water temperature (IN = 33 °C, OUT = 43 °C) of 670W**; simple connection via plastic hoses from the pneumatics area; **dimensional adjustments to the given installation conditions**

art. no.				
FLKU 10 ...			<p>... ST</p>	<p>... ST</p>
		* ground flat		
please indicate:		... mounting method (optional) ST = with solder pin		
material:		stainless steel 1.4404		

Standard aluminium profiles

- length, drilling and surface finishes to customer's instructions
- other standard profiles on request

U-profiles

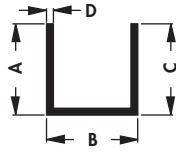

art. no.	A [mm]	B [mm]	C [mm]	D [mm]	art. no.	A [mm]	B [mm]	C [mm]	D [mm]
SU 02	20	40	20	2.5	SU 16	30	30	30	2.0
SU 03				2.0	SU 27	40	40	40	2.5
SU 05	30	20	30	SU 29	4.0				
SU 09	20		20	1.5	SU 32	30	30	30	3.0
tolerances:			EN 755						
material:			EN AW 6060						

flat profiles

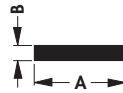

art. no.	A [mm]	B [mm]	art. no.	A [mm]	B [mm]
SFP 005	40	15	SFP 058	40	8
SFP 006	30	8	SFP 060	80	
SFP 007	40	5	SFP 067	30	15
SFP 016	70	15	SFP 074	70	10
SFP 028	40	10	SFP 076	60	30
SFP 029	30		SFP 079	90	100
SFP 037	55		SFP 090	120	15
SFP 046	25	5	SFP 100	100	
SFP 054	50	10	SFP 106	40	20
SFP 057	115	100	SFP 112	100	25
tolerances:			EN 755		
material:			EN AW 6060		

angled profile

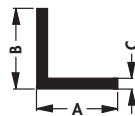

art. no.	A [mm]	B [mm]	C [mm]	art. no.	A [mm]	B [mm]	C [mm]
SWP 02	80	80	8	SWP 29	15	10	2
SWP 06		40	6	SWP 36	75	50	5
SWP 10	30	20	2	SWP 40	40	30	
SWP 15	40		4	SWP 55		40	
SWP 23	20	15	2	SWP 57	60	30	
SWP 25	50	30	5				
tolerances:			EN 755				
material:			EN AW 6060				

Standard aluminium profiles

quadrangular profile

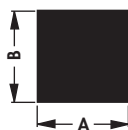

art. no.	A [mm]	B [mm]	art. no.	A [mm]	B [mm]
SVP 01	8	8	SVP 12	50	50
SVP 04	25	25	SVP 13	55	55
SVP 10	10	10			
tolerances:		EN 755			
material:		EN AW 6060			

T-profile

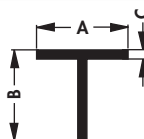

art. no.	A [mm]	B [mm]	C [mm]	art. no.	A [mm]	B [mm]	C [mm]
STP 4	60	60	6	STP 5	20	20	2
tolerances:			EN 755				
material:			EN AW 6060				

B

C

D

E

F

G

H

I

K

L

M

Special profiles

Whenever you cannot find the ideal solution for your problem from the wide range of standard extrusions on offer or a solution constitutes a compromise between the use of the space available and the weight, as long as the quantity is correct a special section is the answer.

Released from the dimensional restrictions of the standard profiles, special extrusions are tailored to your design requirements, and offer considerable benefits in terms of machining time and use of space.

Furthermore your calculation will be influenced positively by the optimised material use and shorter machining times.

You can determine the combination of the desired thermal properties and the design element yourself, by the use of a special profile.

We are not allowed to publish many of our customer-specific Profiles, because they are subject to „non disclosure agreements“.

Therefore we only show some examples for customer profiles in the industry.

All figures are illustrations. Changes reserved.

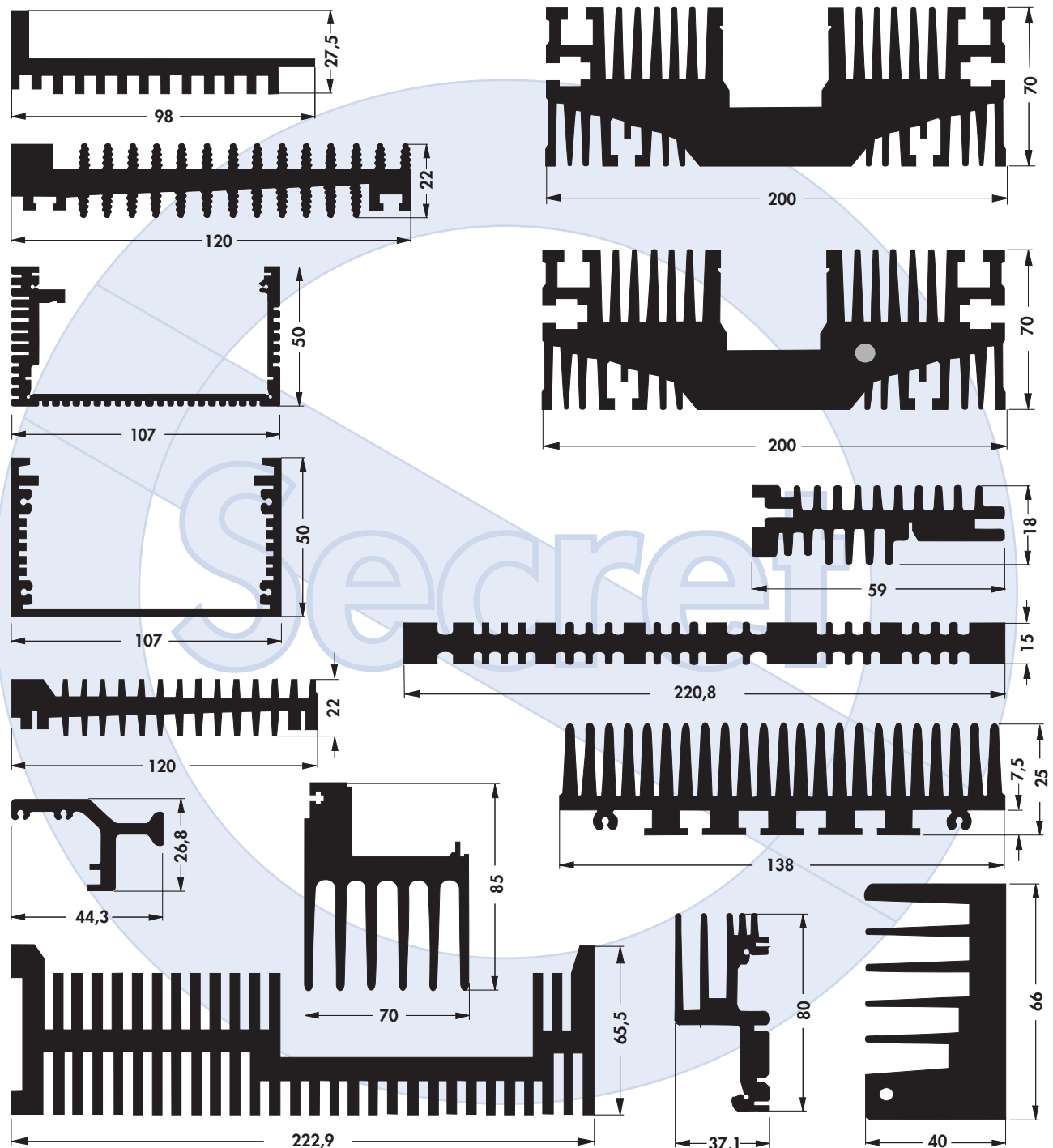

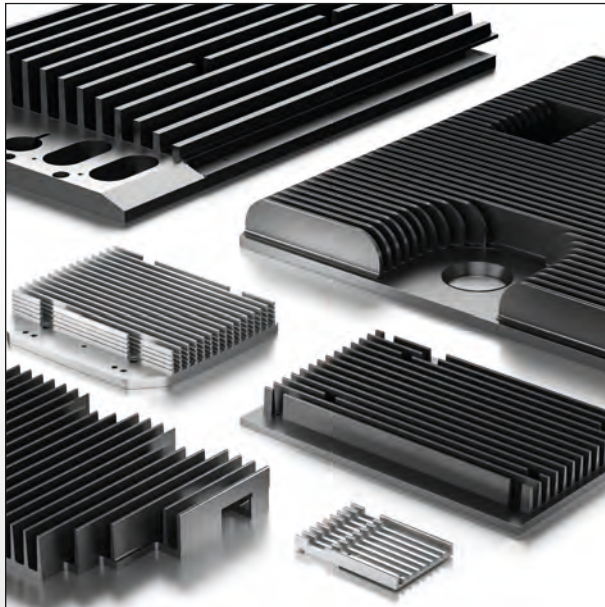

Customer specified CNC treatments of cooling profiles

- latest CNC machining centres for highest quality demands
- profile treatments for sizes up to 1600 mm
- future orientated stockkeeping of the aluminium profiles in fully automated honeycomb warehouses
- batch size optimized production flow
- special profiles, modifications and surfaces according to your special demand

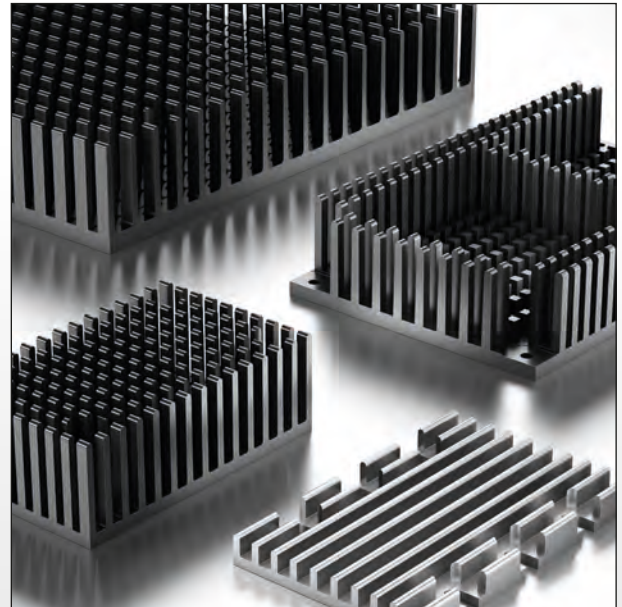

Streamlined omnidirectional fin geometrie

- free-standing cooling fingers for forced cooling
- incident flow of the heatsinks by means of fans from all sides (omnidirectional)
- no direction-oriented installation position
- fin spacings according to your demand
- special designs, treatments and versions according to customer's request



Extruded heatsinks with pressed-in fins

- for highest thermal dissipation losses
- channelled fin geometrie for increasing the surface
- thermotechnical optimized connection between fin and bottom plate
- deliverable in widths of 200 up to 750 mm
- customer specific versions and treatments



Precise milled flat surfaces

- very small depth of roughness and unevenness
- individually milled flat semi-conductor mounting surfaces for minimizing the heat-transmission resistances
- millings on the already anodized heatsinks
- protective foil avoid scratching of the high-quality mounting surface
- special designs according to customer's drawing



Surface labelling

- durable and high quality labeling by means of YAG-laser, silk screen-, pad and digital printing
- print layout preparation by means of in-house repro department
- precise in contrast, precise engraved fonts and contours by means of CNC-controlled treatment systems
- labeling of aluminium, Plexiglas and plastics

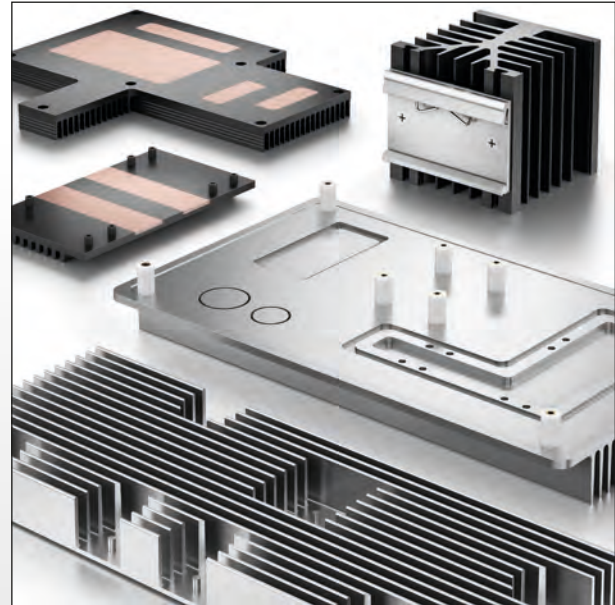

Additional equipments

- fractional semi-conductor mounting surfaces made of copper for heat dissipation
- pressed-in or screwed distance sleeves made of metal and plastics
- threaded bolts with internal and external thread
- support rail mountings made of metal or plastics according to DIN EN 50022

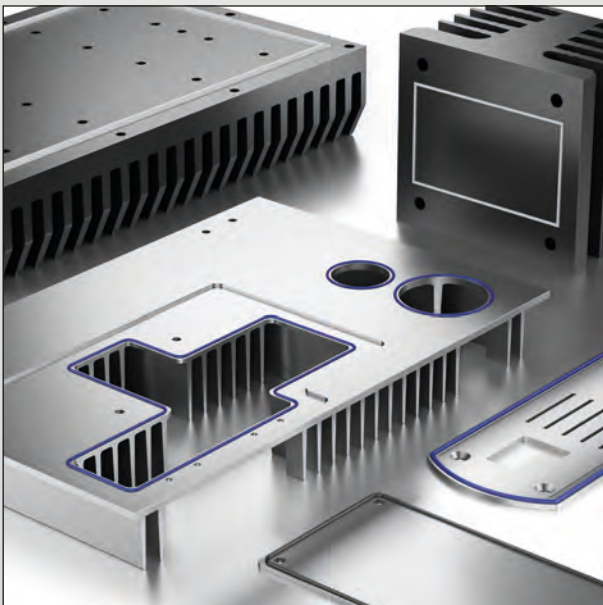

Heatsinks with integrated sealing

- foamed sealing applied on the profile as a permanent element of the heatsink
- also usable for front plates or milled parts
- groove filled or stacked
- permanently elastic and CFC-free
- adaption of the sealing properties to the specific application

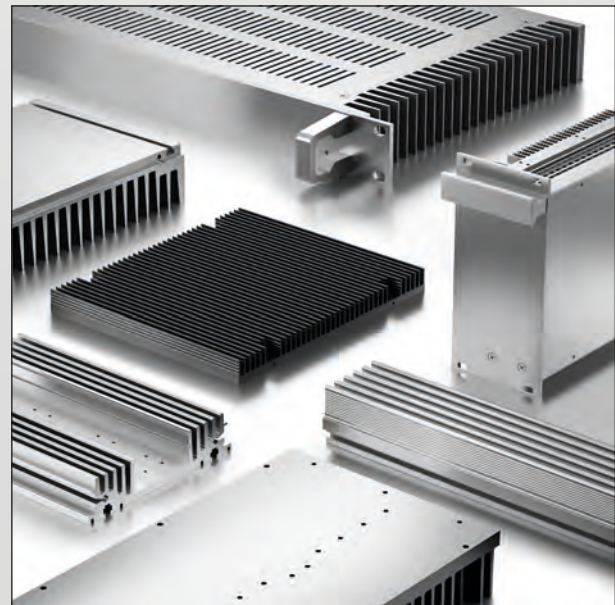

19" compliant CNC-treatment

- milled heatsink side or back panels for 19" cases, 19" plug in boxes, subracks and insert modules
- pressing in or welding of threaded bolts
- customer specified modifications, designs
- surfaces and printing upon request

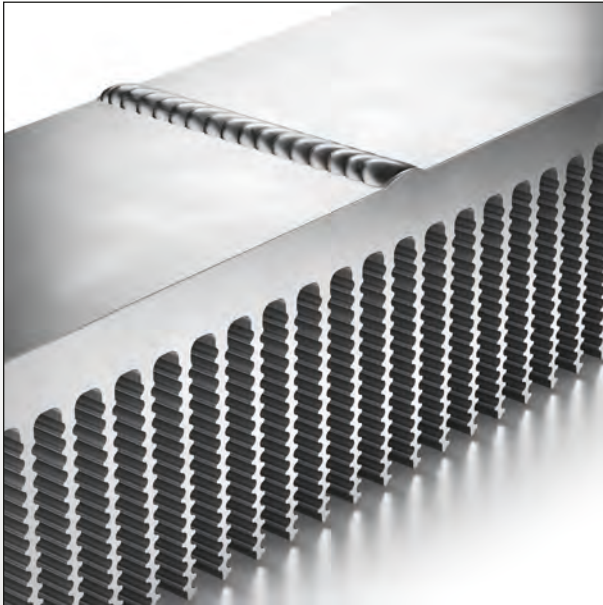

Welded high performance heatsinks

- optimal fin geometry with channelled structure for free convection
- production of heatsink widths outside of the press-technical production possibilities
- removing of the welding line by means of precise milled flat surfaces
- individual surface design

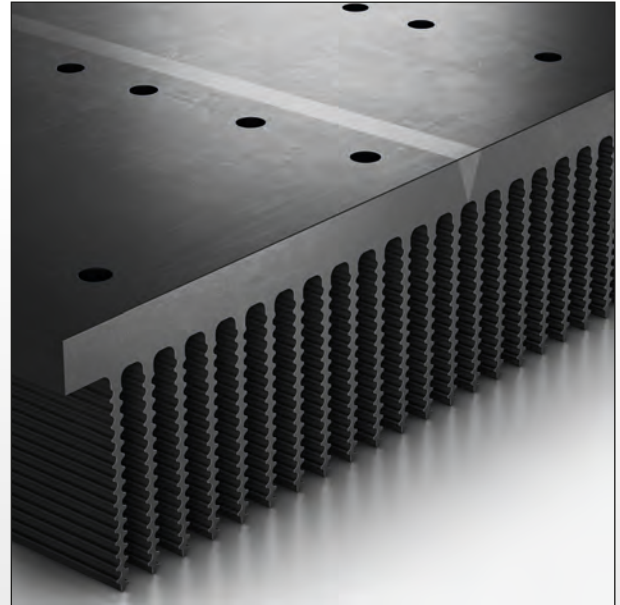

Welded heatsinks

- homogeneous connection of the materials by means of special welding methods
- welding on additional mounting levels which are situated diagonally to the pressing direction of the profiles
- production of prototypes
- application-based special designs and treatments according to your demand

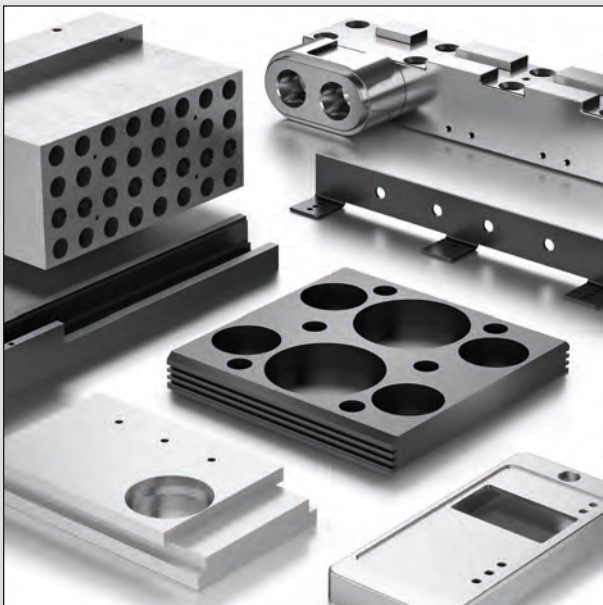

Construction- and milled parts made of aluminium according to customer specifications

- precise milled contours and surfaces
- inserting of holes and cut-outs, cutting or milling of threads
- turning in of wire thread inserts for high- and wear-resistant threads
- simple data exchange by means of up to date CAD-/CAM-systems

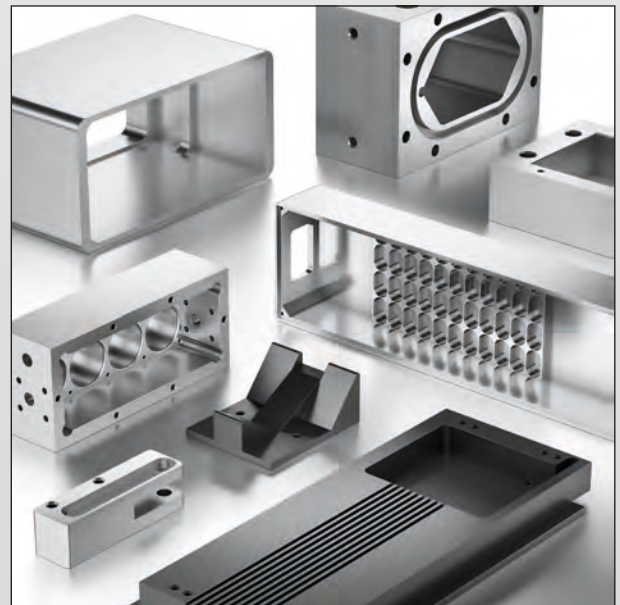

Cases and contour milled parts made of aluminium

- customer specific cases and construction parts
- precise mechanical treatments for highest quality demands
- all requested surface designs
- modifications and versions, special requirements, treatments and designs according to your drawing specification

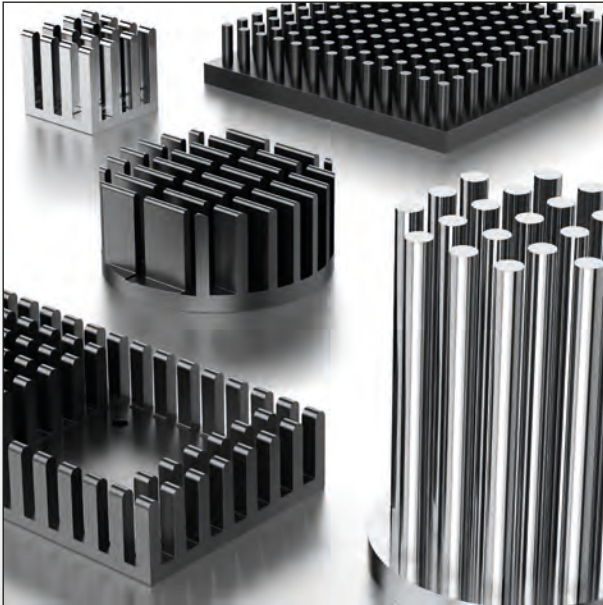

Round and pin heatsinks

- streamlined omnidirectional fin geometrie
- excellent thermal conductivity due to special aluminium alloys
- suitable for free and forced convection
- no direction bounded installation position
- flat semiconductor mounting surfaces
- contour also as milled parts according to your demands



Heatsinks for LEDs

- various heatsink geometries adjusted to all current LED-types and light-engines
- star shaped heatsinks for the use as a LED-lamp housing
- LED mounting by means of screws, thermal conductive adhesive foil or thermal conductive glue
- customer specified versions with application based „thermal management“

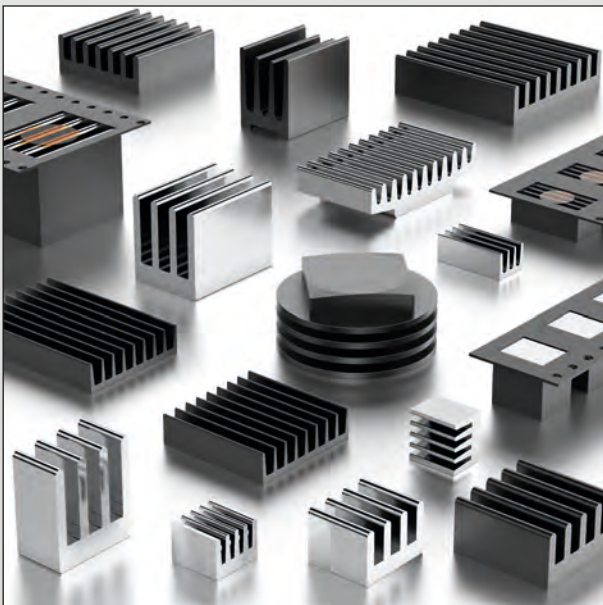

Heatsinks for all current PL, CC, DIL-IC and SMD transistor types

- effective heat dissipation at a low profile and low weight
- direct mounting of the component by means of a double-sided adhesive thermal foil or glue
- solderable versions of the surface
- special packaging such as tape & reel, magazine or tray upon request

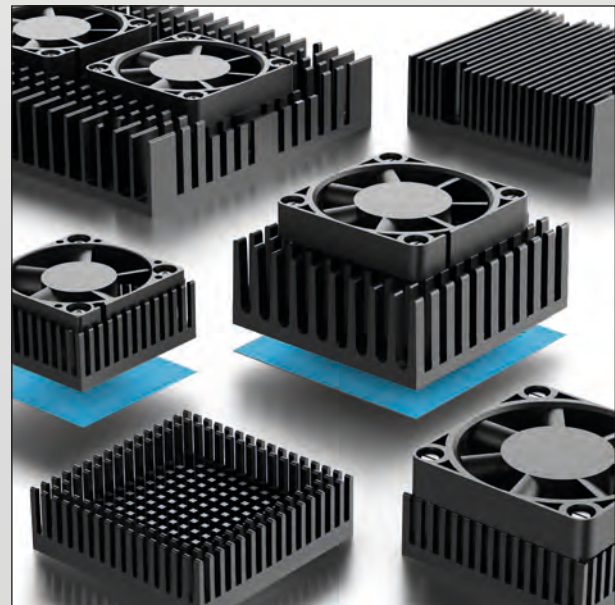

Heatsinks and coolers for processors

- passive and active product solutions
- effective heat dissipation due to optimal conception of fan and heatsink
- long lifetime and high operating safety due to high quality fans
- versions for screw, glue and clip mounting
- customer specific solutions and fans

art. no.	page	R_{th} [K/W]	dissipation loss [W]	way of fixation	socket	suitable for processor type
ICK PGA 6 x 6 x 14	B 12	20	6.4	therm. conductive foil/ therm. cond. adhesive	universal	universal
ICK PGA 8 x 8 x 12	B 12	14.8	8.1	therm. conductive foil/ therm. cond. adhesive	universal	universal
ICK PGA 9 x 9	B 12	14	3	therm. conductive foil/ therm. cond. adhesive	universal	universal
ICK PGA 11 x 11 x 8	B 12	16	7.5	therm. conductive foil/ therm. cond. adhesive	universal	universal
ICK PGA 11 x 11 x 12	B 13	12.3	3.9	therm. conductive foil/ therm. cond. adhesive	universal	universal
ICK PGA 11 x 11	B 13	10.9	4.5	therm. conductive foil/ therm. cond. adhesive	universal	universal
ICK PGA 14 x 14	B 13	10	4.9	therm. conductive foil/ therm. cond. adhesive	universal	universal
ICK PGA 14 x 14 x 10	B 13	10.5	11.2	therm. conductive foil/ therm. cond. adhesive	universal	universal
ICK PGA 14 x 14 x 14	B 13	9.6	12.5	therm. conductive foil/ therm. cond. adhesive	universal	universal
ICK PGA 14 x 14 x 12	B 14	9.8	5.3	therm. conductive foil/ therm. cond. adhesive	universal	universal
ICK PGA 15 x 15	B 14	9.4	5.9	therm. conductive foil/ therm. cond. adhesive	universal	universal
ICK PGA 16 x 16 x 8	B 14	14	4.9	therm. conductive foil/ therm. cond. adhesive	universal	universal
ICK PGA 16 x 16 x 10	B 14	10.5	12.9	therm. conductive foil/ therm. cond. adhesive	universal	universal
ICK PGA 16 x 16 x 12	B 14	9.3	6.2	therm. conductive foil/ therm. cond. adhesive	universal	universal
ICK PGA 17 x 17 x 8	B 15	13.2	5.2	therm. conductive foil/ therm. cond. adhesive	universal	universal
ICK PGA 17 x 17	B 15	8.6	6.9	therm. conductive foil/ therm. cond. adhesive	universal	universal
ICK PGA 17 x 17 x 12	B 15	9	6.5	therm. conductive foil/ therm. cond. adhesive	universal	universal
ICK PGA 18 x 18	B 15	8.4	7.2	therm. conductive foil/ therm. cond. adhesive	universal	universal
ICK PGA 19 x 19 x 12	B 15	9	6.9	therm. conductive foil/ therm. cond. adhesive	universal	universal
ICK PGA 19 x 19	B 16	8.6	7.6	therm. conductive foil/ therm. cond. adhesive	universal	universal
ICK PGA 20 x 20 x 10	B 16	8.5	15.1	therm. conductive foil/ therm. cond. adhesive	universal	universal
ICK PGA 20 x 20 x 8	B 16	12	6.3	therm. conductive foil/ therm. cond. adhesive	universal	universal
ICK PGA 20 x 20	B 16	7.6	8.3	therm. conductive foil/ therm. cond. adhesive	universal	universal
ICK PGA 20 x 20 K	B 16	7.6	8.3	fixing clamp	socket 7/ socket 370	IDT W2A/ AMD® K6-III/ AMD® K6-2/ MMX/ IDT C6/ Intel® Pentium®
ICK PGA 20 x 20 x 12	B 17	8	8.1	therm. conductive foil/ therm. cond. adhesive	universal	universal
ICK PGA 21 x 21	B 17	7	8.6	therm. conductive foil/ therm. cond. adhesive	universal	universal
ICK PGA 22 x 22	B 17	6.2	8.9	therm. conductive foil/ therm. cond. adhesive	universal	universal

- very good thermal efficiency
- aerodynamic imnidirectional fin geometry
- simple mounting by means fo fixing clamp, thermal conductive adhesive film or thermal conductive glue
- customer specified designs, surfaces and modifications upon request

Heatsinks for IC processor

art. no.	page	R_{th} [K/W]	dissipation loss [W]	way of fixation	socket	suitable for processor type
ICK PGA 25 x 25	B 17	5	11.1	therm. conductive foil/ therm. cond. adhesive	universal	universal
ICK BGA 10 x 10	B 18	32	1.8	therm. conductive foil/ therm. cond. adhesive	universal	universal
ICK BGA 10 x 10 x 10	B 18	28.5	1.9	therm. conductive foil/ therm. cond. adhesive	universal	universal
ICK BGA 11 x 11 x 6	B 18	31	1.9	therm. conductive foil/ therm. cond. adhesive	universal	universal
ICK BGA 11 x 11 x 10	B 18	27.5	2.2	therm. conductive foil/ therm. cond. adhesive	universal	universal
ICK BGA 11 x 11 x 14	B 19	25.5	2.3	therm. conductive foil/ therm. cond. adhesive	universal	universal
ICK BGA 12 x 12 x 18	B 19	24.5	2.3	therm. conductive foil/ therm. cond. adhesive	universal	universal
ICK BGA 14 x 14	B 19	30	2.1	therm. conductive foil/ therm. cond. adhesive	universal	universal
ICK BGA 14 x 14 x 10	B 19	27.4	2.3	therm. conductive foil/ therm. cond. adhesive	universal	universal
ICK BGA 14 x 14 x 14	B 19	25.9	2.3	therm. conductive foil/ therm. cond. adhesive	universal	universal
ICK BGA 15 x 15 x 6	B 20	29.5	2	therm. conductive foil/ therm. cond. adhesive	universal	universal
ICK BGA 15 x 15 x 10	B 20	27	2.2	therm. conductive foil/ therm. cond. adhesive	universal	universal
ICK BGA 15 x 15 x 14	B 20	25.5	2.3	therm. conductive foil/ therm. cond. adhesive	universal	universal
ICK BGA 19 x 19 x 6	B 20	27	2	therm. conductive foil/ therm. cond. adhesive	universal	universal
ICK BGA 19 x 19 x 10	B 20	26	2.3	therm. conductive foil/ therm. cond. adhesive	universal	universal
ICK BGA 19 x 19 x 14	B 20	21	2.8	therm. conductive foil/ therm. cond. adhesive	universal	universal
ICK BGA 21 x 21	B 21	24.3	2.5	therm. conductive foil/ therm. cond. adhesive	universal	universal
ICK BGA 21 x 21 x 10	B 21	23	2.6	therm. conductive foil/ therm. cond. adhesive	universal	universal
ICK BGA 21 x 21 x 14	B 21	20	3	therm. conductive foil/ therm. cond. adhesive	universal	universal
ICK BGA 23 x 23	B 21	22.5	2.8	therm. conductive foil/ therm. cond. adhesive	universal	universal
ICK BGA 23 x 23 x 10	B 21	21.5	2.9	therm. conductive foil/ therm. cond. adhesive	universal	universal
ICK BGA 25 x 25 x 6	B 21	21.25	2.8	therm. conductive foil/ therm. cond. adhesive	universal	universal
ICK BGA 25 x 25 x 10	B 22	20	3	therm. conductive foil/ therm. cond. adhesive	universal	universal
ICK BGA 25 x 25 x 14	B 22	17	3.5	therm. conductive foil/ therm. cond. adhesive	universal	universal
ICK BGA 27 x 27	B 22	20	3.1	therm. conductive foil/ therm. cond. adhesive	universal	universal
ICK BGA 27 x 27 x 10	B 22	18.5	3.3	therm. conductive foil/ therm. cond. adhesive	universal	universal
ICK BGA 27 x 27 x 14	B 22	13.5	9.5	therm. conductive foil/ therm. cond. adhesive	universal	universal
ICK BGA 27 x 27 x 22	B 23	10.5	9.5	therm. conductive foil/ therm. cond. adhesive	universal	universal
ICK BGA 29 x 29 x 6	B 23	19.5	3	therm. conductive foil/ therm. cond. adhesive	universal	universal

- very good thermal efficiency
- aerodynamic imnidirectional fin geometry
- simple mounting by means fo fixing clamp, thermal conductive adhesive film or thermal conductive glue
- customer specified designs, surfaces and modifications upon request

art. no.	page	R_{th} [K/W]	dissipation loss [W]	way of fixation	socket	suitable for processor type
ICK BGA 29 x 29 x 10	B 23	18	3.3	therm. conductive foil/ therm. cond. adhesive	universal	universal
ICK BGA 29 x 29 x 14	B 23	17	3.5	therm. conductive foil/ therm. cond. adhesive	universal	universal
ICK BGA 31 x 31	B 23	18.6	3.4	therm. conductive foil/ therm. cond. adhesive	universal	universal
ICK BGA 31 x 31 x 10	B 24	17	3.7	therm. conductive foil/ therm. cond. adhesive	universal	universal
ICK BGA 33 x 33 x 6	B 24	17.5	3.4	therm. conductive foil/ therm. cond. adhesive	universal	universal
ICK BGA 33 x 33 x 10	B 24	16.5	3.6	therm. conductive foil/ therm. cond. adhesive	universal	universal
ICK BGA 33 x 33 x 14	B 24	15	4	therm. conductive foil/ therm. cond. adhesive	universal	universal
ICK BGA 35 x 35	B 24	16.5	3.7	therm. conductive foil/ therm. cond. adhesive	universal	universal
ICK BGA 35 x 35 x 10	B 25	15.7	3.8	therm. conductive foil/ therm. cond. adhesive	universal	universal
ICK BGA 37 x 37 x 6	B 25	15.7	9.5	therm. conductive foil/ therm. cond. adhesive	universal	universal
ICK BGA 37 x 37 x 10	B 25	14	10.5	therm. conductive foil/ therm. cond. adhesive	universal	universal
ICK BGA 40 x 40	B 25	14.6	4.3	therm. conductive foil/ therm. cond. adhesive	universal	universal
ICK BGA 40 x 40 x 10	B 25	13.8	4.4	therm. conductive foil/ therm. cond. adhesive	universal	universal
ICK BGA 42,5 x 45	B 26	13.6	4.2	therm. conductive foil/ therm. cond. adhesive	universal	universal
ICK S 10 x 10 x 6,5	B 27	25	2.5	therm. conductive foil/ therm. cond. adhesive	universal	universal
ICK S 10 x 10 x 10	B 27	23.75	2.6	therm. conductive foil/ therm. cond. adhesive	universal	universal
ICK S 10 x 10 x 12,5	B 27	22.5	2.8	therm. conductive foil/ therm. cond. adhesive	universal	universal
ICK S 10 x 10 x 18,5	B 28	21.75	3	therm. conductive foil/ therm. cond. adhesive	universal	universal
ICK S 14 x 14 x 6,5	B 28	9	5	therm. conductive foil/ therm. cond. adhesive	universal	universal
ICK S 14 x 14 x 10	B 28	8.8	5.1	therm. conductive foil/ therm. cond. adhesive	universal	universal
ICK S 14 x 14 x 12,5	B 28	8.1	5.4	therm. conductive foil/ therm. cond. adhesive	universal	universal
ICK S 14 x 14 x 18,5	B 28	7.9	5.6	therm. conductive foil/ therm. cond. adhesive	universal	universal
ICK S 17 x 17 x 15	B 29	8.36	5.95	therm. conductive foil/ therm. cond. adhesive	universal	universal
ICK S 17 x 17 x 20	B 29	7.89	6.3	therm. conductive foil/ therm. cond. adhesive	universal	universal
ICK S 18 x 18 x 6,5	B 29	7	7.7	therm. conductive foil/ therm. cond. adhesive	universal	universal
ICK S 18 x 18 x 10	B 29	6.8	8	therm. conductive foil/ therm. cond. adhesive	universal	universal
ICK S 22 x 22 x 6,5	B 29	6.4	13.3	therm. conductive foil/ therm. cond. adhesive	universal	universal
ICK S 22 x 22 x 10	B 30	5.9	8.5	therm. conductive foil/ therm. cond. adhesive	universal	universal
ICK S 22 x 22 x 18,5	B 30	5	10	therm. conductive foil/ therm. cond. adhesive	universal	universal

- very good thermal efficiency
- aerodynamic imnidirectional fin geometry
- simple mounting by means fo fixing clamp, thermal conductive adhesive film or thermal conductive glue
- customer specified designs, surfaces and modifications upon request

art. no.	page	R_{th} [K/W]	dissipation loss [W]	way of fixation	socket	suitable for processor type
ICK S 25 x 25 x 6,5	B 30	5.8	12.9	therm. conductive foil/ therm. cond. adhesive	universal	universal
ICK S 25 x 25 x 12,5	B 30	5.3	14.1	therm. conductive foil/ therm. cond. adhesive	universal	universal
ICK S 25 x 25 x 18,5	B 30	5.2	14.4	therm. conductive foil/ therm. cond. adhesive	universal	universal
ICK S 29 x 29 x 10	B 31	5.7	13.1	therm. conductive foil/ therm. cond. adhesive	universal	universal
ICK S 29 x 29 x 20	B 31	3.7	20.2	therm. conductive foil/ therm. cond. adhesive	universal	universal
ICK S 29 x 29 x 30	B 31	2.9	21	therm. conductive foil/ therm. cond. adhesive	universal	universal
ICK S 32 x 32 x 10	B 31	5.4	13.8	therm. conductive foil/ therm. cond. adhesive	universal	universal
ICK S 32 x 32 x 20	B 31	3.7	20.4	therm. conductive foil/ therm. cond. adhesive	universal	universal
ICK S 36 x 36 x 10	B 32	4.7	16	therm. conductive foil/ therm. cond. adhesive	universal	universal
ICK S 36 x 36 x 15	B 32	3.9	19.2	therm. conductive foil/ therm. cond. adhesive	universal	universal
ICK S 36 x 36 x 20	B 32	3.2	22	therm. conductive foil/ therm. cond. adhesive	universal	universal
ICK S 36 x 36 x 28.5	B 32	2.7	25	therm. conductive foil/ therm. cond. adhesive	universal	universal
ICK S 36 x 36 x 30	B 32	2.5	23.4	therm. conductive foil/ therm. cond. adhesive	universal	universal
ICK S 40 x 40 x 7,5	B 33	4.85	15.5	therm. conductive foil/ therm. cond. adhesive	universal	universal
ICK S 40 x 40 x 10	B 33	4.6	16.3	therm. conductive foil/ therm. cond. adhesive	universal	universal
ICK S 40 x 40 x 20	B 33	3.5	21.4	therm. conductive foil/ therm. cond. adhesive	universal	universal
ICK S 40 x 40 x 25	B 33	3.1	23.7	therm. conductive foil/ therm. cond. adhesive	universal	universal
ICK S 45 x 45 x 10	B 33	4.7	16	therm. conductive foil/ therm. cond. adhesive	universal	universal
ICK S 45 x 45 x 20	B 34	4.4	17	therm. conductive foil/ therm. cond. adhesive	universal	universal
ICK S 50 x 50 x 10	B 34	2.7	20	therm. conductive foil/ therm. cond. adhesive	universal	universal
ICK S 50 x 50 x 20	B 34	2.7	27.7	therm. conductive foil/ therm. cond. adhesive	universal	universal
ICK S 50 x 50 x 25	B 34	2.4	31.2	therm. conductive foil/ therm. cond. adhesive	universal	universal
ICK S 50 x 50 x 40	B 34	6.05	13.5	therm. conductive foil/ therm. cond. adhesive	universal	universal
ICK S 50 x 50 x 50	B 35	4.05	14.32	therm. conductive foil/ therm. cond. adhesive	universal	universal
ICK S 98 x 98 x 30	B 35	2.4	35	therm. conductive foil/ therm. cond. adhesive	universal	universal
ICK S 98 x 98 x 45	B 35	3.5	42	therm. conductive foil/ therm. cond. adhesive	universal	universal
ICK S D 12 x 12 x 7,5	B 36	48	2.1	therm. conductive foil/ therm. cond. adhesive	universal	universal
ICK S D 18 x 12 x 7,5	B 36	9	5.4	therm. conductive foil/ therm. cond. adhesive	universal	universal
ICK S D 24 x 18 x 7,5	B 36	8.5	5.85	therm. conductive foil/ therm. cond. adhesive	universal	universal

- very good thermal efficiency
- aerodynamic imnidirectional fin geometry
- simple mounting by means fo fixing clamp, thermal conductive adhesive film or thermal conductive glue
- customer specified designs, surfaces and modifications upon request

art. no.	page	R_{th} [K/W]	dissipation loss [W]	way of fixation	socket	suitable for processor type
ICK S D 98 x 98 x 10	B 36	4.88	10.25	therm. conductive foil/ therm. cond. adhesive	universal	universal
ICK S R 28,5 x 6,5	B 37	17.3	3.47	therm. conductive foil/ therm. cond. adhesive	universal	universal
ICK S R 28,5 x 10	B 37	13.9	4.32	therm. conductive foil/ therm. cond. adhesive	universal	universal
ICK S R 28,5 x 12,5	B 37	10.3	5.83	therm. conductive foil/ therm. cond. adhesive	universal	universal
ICK S R 28,5 x 18,5	B 38	10.1	5.94	therm. conductive foil/ therm. cond. adhesive	universal	universal
ICK S R 32,5 x 10	B 38	11.9	5.04	therm. conductive foil/ therm. cond. adhesive	universal	universal
ICK S R 32,5 x 20	B 38	10	6	therm. conductive foil/ therm. cond. adhesive	universal	universal
ICK S R 32,5 x 30	B 38	8.8	6.82	therm. conductive foil/ therm. cond. adhesive	universal	universal
ICK S R 32,5 x 40	B 38	7.6	7.89	therm. conductive foil/ therm. cond. adhesive	universal	universal
ICK S R 32,5 x 50	B 39	6.6	9.09	therm. conductive foil/ therm. cond. adhesive	universal	universal
ICK S R 36,5 x 20	B 39	7.2	8.33	therm. conductive foil/ therm. cond. adhesive	universal	universal
ICK S R 40 x 10	B 39	7.1	8.45	therm. conductive foil/ therm. cond. adhesive	universal	universal
ICK S R 40 x 20	B 39	6.05	9.92	therm. conductive foil/ therm. cond. adhesive	universal	universal
ICK S R A 40 x 20	B 39	7.6	7.89	therm. conductive foil/ therm. cond. adhesive	universal	universal
ICK S R 40 x 30	B 40	6.1	9.84	therm. conductive foil/ therm. cond. adhesive	universal	universal
ICK S R 40 x 50	B 40	4.5	13.33	therm. conductive foil/ therm. cond. adhesive	universal	universal
ICK S R 45 x 30	B 40	6	10	therm. conductive foil/ therm. cond. adhesive	universal	universal
ICK S R 45 x 45	B 40	4.4	13.64	therm. conductive foil/ therm. cond. adhesive	universal	universal
ICK S R 50 x 10	B 40	6	10	therm. conductive foil/ therm. cond. adhesive	universal	universal
ICK S R 50 x 20	B 41	7	8.57	therm. conductive foil/ therm. cond. adhesive	universal	universal
ICK S R 50 x 30	B 41	6.1	9.84	therm. conductive foil/ therm. cond. adhesive	universal	universal
ICK S R 50 x 45	B 41	5.1	11.76	therm. conductive foil/ therm. cond. adhesive	universal	universal
ICK S R 54 x 20	B 41	6.1	9.84	therm. conductive foil/ therm. cond. adhesive	universal	universal
ICK S R 54 x 30	B 41	5.05	11.88	therm. conductive foil/ therm. cond. adhesive	universal	universal
ICK S R 54 x 45	B 42	4.1	14.63	therm. conductive foil/ therm. cond. adhesive	universal	universal
ICK S R 70 x 30	B 42	4	15	therm. conductive foil/ therm. cond. adhesive	universal	universal
ICK S R 70 x 50	B 42	3.5	17.14	therm. conductive foil/ therm. cond. adhesive	universal	universal
ICK S R 85 x 30	B 42	3.7	16.22	therm. conductive foil/ therm. cond. adhesive	universal	universal
ICK S R 85 x 45	B 42	3.4	17.65	therm. conductive foil/ therm. cond. adhesive	universal	universal

- very good thermal efficiency
- aerodynamic imnidirectional fin geometry
- simple mounting by means fo fixing clamp, thermal conductive adhesive film or thermal conductive glue
- customer specified designs, surfaces and modifications upon request

Heatsinks for IC processor

art. no.	page	R_{th} [K/W]	dissipation loss [W]	way of fixation	socket	suitable for processor type
ICK S R 98 x 30	B 43	3.7	16.22	therm. conductive foil/ therm. cond. adhesive	universal	universal
ICK S R 98 x 50	B 43	2.95	20.34	therm. conductive foil/ therm. cond. adhesive	universal	universal
ICK S R 100 x 50	B 43	2.3	26	therm. conductive foil/ therm. cond. adhesive	universal	universal
ICK S R 100 x 70	B 43	2	30	therm. conductive foil/ therm. cond. adhesive	universal	universal
ICK S R 120 x 50	B 44	1.9	31.6	therm. conductive foil/ therm. cond. adhesive	universal	universal
ICK S R 120 x 70	B 44	1.8	33.3	therm. conductive foil/ therm. cond. adhesive	universal	universal
ICK S R 140 x 50	B 44	1.85	32.4	therm. conductive foil/ therm. cond. adhesive	universal	universal
ICK S R 140 x 70	B 44	1.7	35.3	therm. conductive foil/ therm. cond. adhesive	universal	universal
ICK S R 160 x 70	B 45	1.6	37.5	therm. conductive foil/ therm. cond. adhesive	universal	universal
ICK LED R 23,5 x 14	B 46	18.58	6.5	therm. conductive foil/ therm. cond. adhesive	universal	universal
ICK LED R 23,5 x 14 G	B 46	19.16	6.3	therm. conductive foil/ therm. cond. adhesive	universal	universal
ICK LED R 27 x 10	B 46	17.69	6.7	therm. conductive foil/ therm. cond. adhesive	universal	universal
ICK LED R 27 x 10 G	B 46	18.24	6.6	therm. conductive foil/ therm. cond. adhesive	universal	universal
ICK LED R 28 x 15	B 46	15.24	7.8	therm. conductive foil/ therm. cond. adhesive	universal	universal
ICK LED R 28 x 15 G	B 47	15.72	7.6	therm. conductive foil/ therm. cond. adhesive	universal	universal
ICK LED R 29 x 11,5	B 47	17.26	8.2	therm. conductive foil/ therm. cond. adhesive	universal	universal
ICK LED R 29 x 11,5 G	B 47	17.8	8	therm. conductive foil/ therm. cond. adhesive	universal	universal
ICK LED R 32 x 14	B 47	15.23	7.8	therm. conductive foil/ therm. cond. adhesive	universal	universal
ICK LED R 32 x 14 G	B 47	15.23	7.6	therm. conductive foil/ therm. cond. adhesive	universal	universal
ICK LED R 33 x 10	B 47	17.6	6.8	therm. conductive foil/ therm. cond. adhesive	universal	universal
ICK LED R 33 x 10 G	B 47	18.15	6.6	therm. conductive foil/ therm. cond. adhesive	universal	universal
ICK LED R 33 x 16,5	B 48	13.87	8.5	therm. conductive foil/ therm. cond. adhesive	universal	universal
ICK LED R 33 x 16,5 G	B 48	14.3	8.3	therm. conductive foil/ therm. cond. adhesive	universal	universal
ICK LED R 35 x 10	B 48	16.9	9.35	therm. conductive foil/ therm. cond. adhesive	universal	universal
ICK LED R 35 x 10 G	B 48	17.5	9.2	therm. conductive foil/ therm. cond. adhesive	universal	universal
ICK LED R 36 x 12	B 48	12.88	10	therm. conductive foil/ therm. cond. adhesive	universal	universal
ICK LED R 36 x 12 G	B 48	13.28	8.9	therm. conductive foil/ therm. cond. adhesive	universal	universal
ICK LED R 40 x 10	B 48	12.28	9.45	therm. conductive foil/ therm. cond. adhesive	universal	universal
ICK LED R 40 x 10 G	B 49	12.66	9.3	therm. conductive foil/ therm. cond. adhesive	universal	universal

- very good thermal efficiency
- aerodynamic imnidirectional fin geometry
- simple mounting by means fo fixing clamp, thermal conductive adhesive film or thermal conductive glue
- customer specified designs, surfaces and modifications upon request

art. no.	page	R_{th} [K/W]	dissipation loss [W]	way of fixation	socket	suitable for processor type
ICK LED R 40 x 27	B 49	9.41	12.1	therm. conductive foil/ therm. cond. adhesive	universal	universal
ICK LED R 40 x 27 G	B 49	9.71	11.9	therm. conductive foil/ therm. cond. adhesive	universal	universal
ICK LED R 45,7 x 16,5	B 49	10.46	11.05	therm. conductive foil/ therm. cond. adhesive	universal	universal
ICK LED R 45,7 x 16,5 G	B 49	10.49	10.8	therm. conductive foil/ therm. cond. adhesive	universal	universal
ICK LED R 50 x 10	B 49	10.57	10.5	therm. conductive foil/ therm. cond. adhesive	universal	universal
ICK LED R 50 x 10 G	B 50	10.9	10.3	therm. conductive foil/ therm. cond. adhesive	universal	universal
ICK LED R 50,8 x 16,5	B 50	10.17	11.1	therm. conductive foil/ therm. cond. adhesive	universal	universal
ICK LED R 50,8 x 16,5 G	B 50	10.49	10.9	therm. conductive foil/ therm. cond. adhesive	universal	universal
ICK LED R 54 x 20	B 50	9.48	12.1	therm. conductive foil/ therm. cond. adhesive	universal	universal
ICK LED R 54 x 20 G	B 50	9.78	11.9	therm. conductive foil/ therm. cond. adhesive	universal	universal
ICK LED R 66 x 40	B 51	3.2	21	therm. conductive foil/ therm. cond. adhesive	universal	universal
ICK LED R 75 x 10	B 51	5.2	12.1	therm. conductive foil/ therm. cond. adhesive	universal	universal
ICK LED R 84 x 40	B 51	2.5	14.5	therm. conductive foil/ therm. cond. adhesive	universal	universal
ICK LED R 100 x 40	B 51	2	27	therm. conductive foil/ therm. cond. adhesive	universal	universal
ICK LED R 160 x 40	B 52	1.4	42	therm. conductive foil/ therm. cond. adhesive	universal	universal
ICK LED R 200 x 40	B 52	1	51	therm. conductive foil/ therm. cond. adhesive	universal	universal
SK LED 1	B 61	15				
SK LED 3	B 61	7				
SK LED 4	B 62	2				
ICK PPC 51	B 70	8.1	14	screw fastening		Power PC
ICK PEN 3 XE	B 70	2	31.3	screw fastening	Slot 2	Intel® Pentium® III- Xeon™ Slot II Format
ICK PEN 3 XE 1	B 70	1.8	33.6	screw fastening	Slot 2	Intel® Pentium® III- Xeon™ Slot II Format
ICK EM 22	B 71	4.4	18.1	screw fastening		μQ7 Board
ICK EM 25	B 71	3.9	20.4	screw fastening		Q7 Board
ICK VB 10	B 71	7.7	10.3	screw fastening		Verdin iMX8M
ICK VB 15	B 71	6.6	12.1	screw fastening		Verdin iMX8M
ICK SM 25	B 72	5.9	10.2	screw fastening		SMARC Short Mod- ule
ICK PEN 38 F	B 73	4	15.1	therm. conductive foil	socket 7/ socket 370	AMD® K6-III/ IDT W2A/ MMX/ IDT C6/ Intel® Pentium®/ AMD® K6-2
ICK PEN 38 W	B 73	4	15.1	therm. cond. adhesive	socket 7/ socket 370	AMD® K6-III/ IDT W2A/ MMX/ IDT C6/ Intel® Pentium®/ AMD® K6-2

- very good thermal efficiency
- aerodynamic imnidirectional fin geometry
- simple mounting by means fo fixing clamp, thermal conductive adhesive film or thermal conductive glue
- customer specified designs, surfaces and modifications upon request

Heatsinks for IC processor

art. no.	page	R_{th} [K/W]	dissipation loss [W]	way of fixation	socket	suitable for processor type
ICK PEN 45 W	B 73	3.5	21	therm. cond. adhesive	socket 7/ socket 370	AMD® K6-III/ IDT W2A/ MMX/ IDT C6/ Intel® Pentium®/ AMD® K6-2
ICK PRO 40 W	B 73	2.7	22	therm. cond. adhesive	socket 8	Intel® Pentium® PRO

- very good thermal efficiency
- aerodynamic omnidirectional fin geometry
- simple mounting by means of fixing clamp, thermal conductive adhesive film or thermal conductive glue
- customer specified designs, surfaces and modifications upon request

art. no.	page	R_{th} [K/W]	dissipation loss [W]	way of fixation	socket	suitable for processor type
LA LED 40 x 30	B 63	1.4	35	therm. conductive foil/ therm. cond. adhesive	universal	universal
LA LED 50 x 20	B 63	1.25	40	therm. conductive foil/ therm. cond. adhesive	universal	universal
LA LED 50 x 45	B 63	0.9	50	therm. conductive foil/ therm. cond. adhesive	universal	universal
LA ICK 15 x 15 F 05	B 74	2.3	22.2	therm. conductive foil	universal	universal
LA ICK 15 x 15 F 12	B 74	2.3	22.2	therm. conductive foil	universal	universal
LA ICK 17 x 17 F 12	B 74	1.6	35.8	therm. conductive foil	universal	universal
LA ICK 17 x 17 F 12 A	B 74	1.6	35.8	therm. conductive foil	universal	universal
LA ICK 17 x 17 W 05	B 74	1.6	35.8	therm. cond. adhesive	universal	universal
LA ICK 17 x 17 W 12	B 74	1.6	35.8	therm. cond. adhesive	universal	universal
LA ICK 18 x 18 F 12	B 74	1.5	41.7	therm. conductive foil	universal	universal
LA ICK 18 x 18 W 12	B 74	1.5	41.7	therm. cond. adhesive	universal	universal
LA ICK 21 x 21 F 05	B 74	1.4	46.3	therm. conductive foil	universal	universal
LA ICK 21 x 21 F 12	B 74	1.4	46.3	therm. conductive foil	universal	universal
LA ICK 21 x 21 W 05	B 74	1.4	46.3	therm. cond. adhesive	universal	universal
LA ICK 21 x 21 W 12	B 74	1.4	46.3	therm. cond. adhesive	universal	universal
LA ICK PEN 8 F 05	B 75	2.5	23.4	therm. conductive foil	socket 7/ socket 370	AMD® K6-III/ IDT W2A/ Cyrix MII and similar/ MMX/ IDT C6/ Intel® Pentium®/ AMD® K6-2
LA ICK PEN 8 W 05	B 75	2.5	23.4	therm. cond. adhesive	socket 7/ socket 370	AMD® K6-III/ IDT W2A/ Cyrix MII and similar/ MMX/ IDT C6/ Intel® Pentium®/ AMD® K6-2
LA ICK PEN 16 W 12	B 75	1.2	51.1	therm. cond. adhesive	socket 7/ socket 370	AMD® K6-III/ IDT W2A/ Cyrix MII and similar/ MMX/ IDT C6/ Intel® Pentium®/ AMD® K6-2
LA ICK PEN 16 W 12 A	B 75	1.2	51.1	therm. cond. adhesive	socket 7/ socket 370	AMD® K6-III/ IDT W2A/ Cyrix MII and similar/ MMX/ IDT C6/ Intel® Pentium®/ AMD® K6-2
LA ICK PEN 18 W 12	B 75	1.6	38.6	therm. cond. adhesive	socket 7/ socket 370	AMD® K6-III/ IDT W2A/ Cyrix MII and similar/ MMX/ IDT C6/ Intel® Pentium®/ AMD® K6-2

- high-quality industrial design
- compact design with high mechanical stability
- fan with doubled ball bearing axis
- optimal thermotechnical design of fan and heatsink

art. no.	page	R_{th} [K/W]	dissipation loss [W]	way of fixation	socket	suitable for processor type
LA ICK PEN 38 W 12	B 75	1.1	53.6	therm. cond. adhesive	socket 7/ socket 370	AMD® K6-III/ IDT W2A/ Cyrix MII and similar/ MMX/ IDT C6/ Intel® Pentium®/ AMD® K6-2
LA ICK PRO 25 F 12	B 75	0.97	60	therm. conductive foil	socket 8	Intel® Pentium® PRO
LA ICK PEN 2 K 12	B 76	1.2	58		Slot A/ Slot 1	Intel® Pentium® II/ AMD® Athlon®
LA ICK PEN 3 XE	B 76	0.8	61.8	screw fastening	Slot 2	Intel® Pentium® III- Xeon™

Heatsinks

- excellent thermal efficiency achieved by flow-favourable omnidirectional fin geometry and black anodised surface
- easy mounting using fixing clamp, thermally conductive adhesive foil or thermally conductive glue

Fan coolers

- special high-grade industrial type
- compact design with high mechanical stability
- fan motor axle with double ball bearings ensures high reliability and long product life
- low current consumption and thus low self-heating
- effective heat dissipation achieved by optimum design of fan motor and heatsink
- fan motors with other operating voltages on request
- fan motors also available with pulse output and alarm device circuit

Technical introduction

- the thermal resistances and the power dissipation were determined with an ambient temperature of 25 °C and an IC case-temperature of 85 °C
- with higher IC case-temperature, the power to be dissipated increases proportionally

Fixing methods

- K** = fixing clamp
- F** = double sided thermally conductive adhesive foil
- W** = thermally conductive glue
- SB** = screw fixing



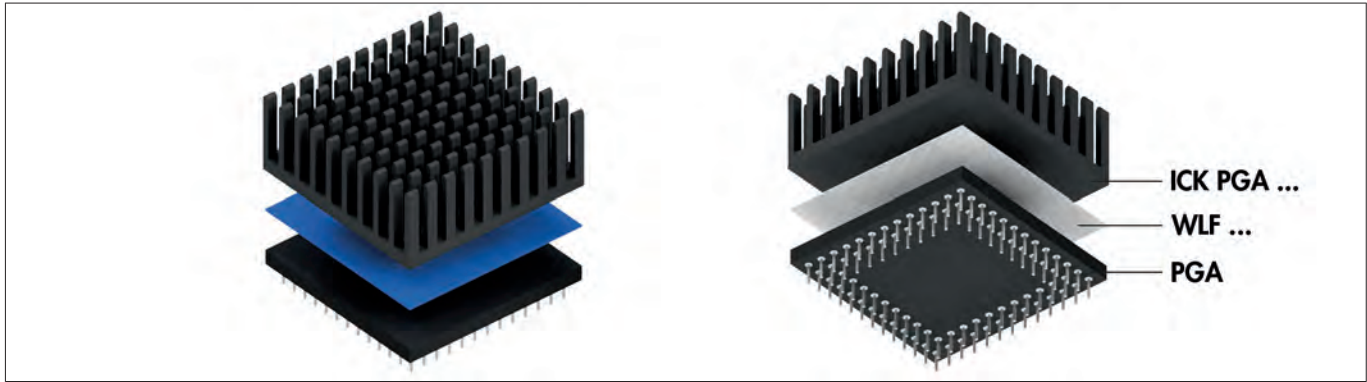

Technical data for fans with pulse output → B 77

- pulse output for control of the alarm device circuit
- puls form is like rectangle with the triple frequency of rotation speed
- with blocked rotor the output signal can be L (0.8 V) or H (Vcc-1V)
- the pulse output must not be connected with GND or Vcc without a mutiplier (>10K)
- to prevent short circuits, do not isolate the used puls output

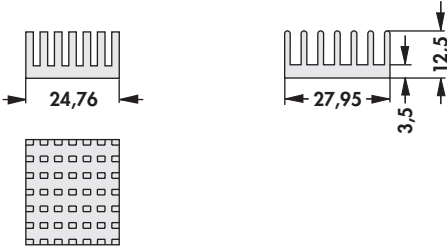
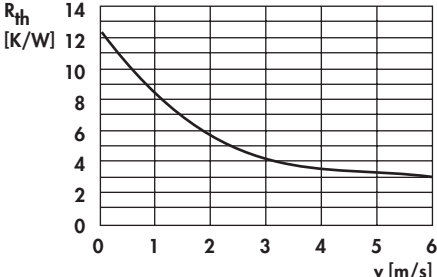
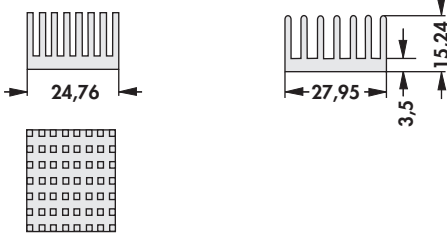

- especially suitable for **P** in **Grid A** arrays
- heat sink dimensions suitable for the respective PGA type
- can be stuck directly onto the PGA component
- double-sided adhesive thermal conductive foil **WLF ...** → 39 - 42

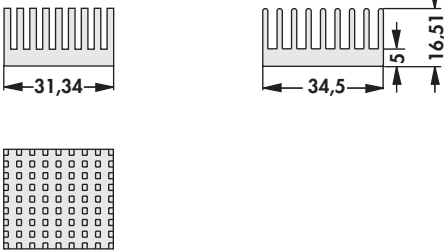
<p>art. no.</p> <p>ICK PGA 6 x 6 x 14 ... WLF ... 14 x 14</p>		
<p>art. no.</p> <p>ICK PGA 8 x 8 x 12 WLF ... 23 x 23</p>		
<p>art. no.</p> <p>ICK PGA 9 x 9 WLF ... 24 x 24</p>		
<p>art. no.</p> <p>ICK PGA 11 x 11 x 8 WLF ... 24 x 27</p>		
<p>surface:</p>		<p>black anodised</p>

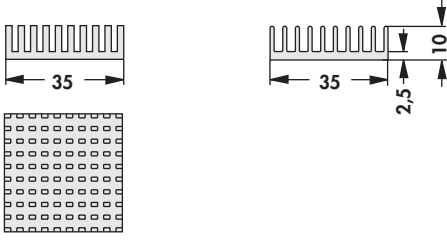
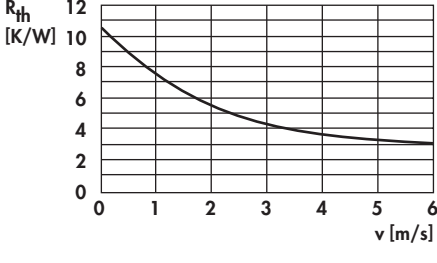
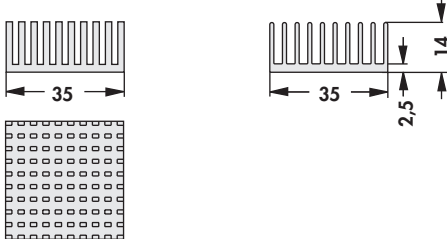
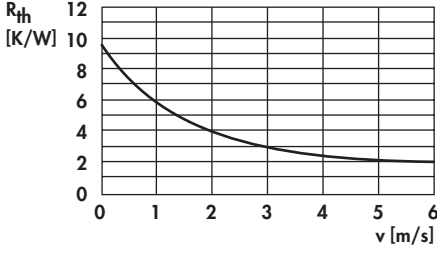
<p>art. no.</p> <p>ICK PGA 11 x 11 x 12 WLF ... 24 x 27</p>		
<p>art. no.</p> <p>ICK PGA 11 x 11 WLF ... 24 x 27</p>		
<p>art. no.</p> <p>ICK PGA 14 x 14 WLF ... 31 x 34</p>		
<p>art. no.</p> <p>ICK PGA 14 x 14 x 10 WLF ... 35 x 35</p>		
<p>art. no.</p> <p>ICK PGA 14 x 14 x 14 WLF ... 35 x 35</p>		
<p>surface:</p>		<p>black anodised</p>

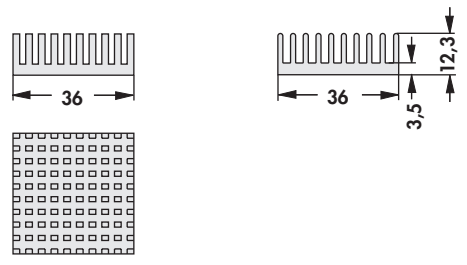
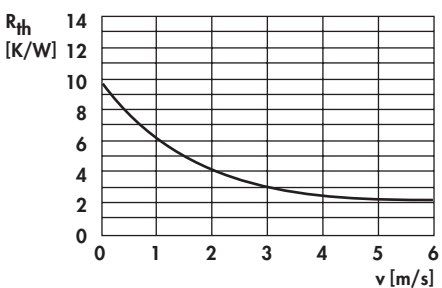
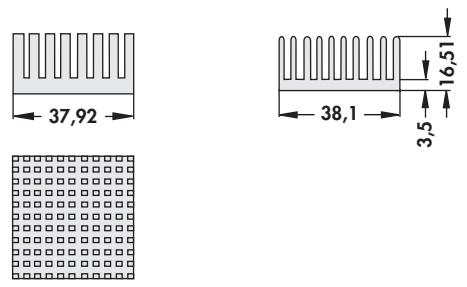
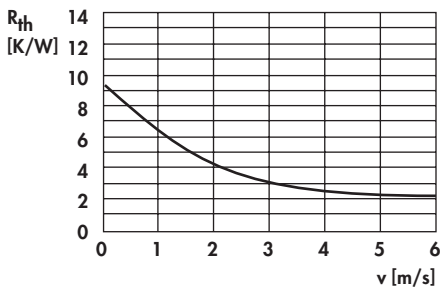
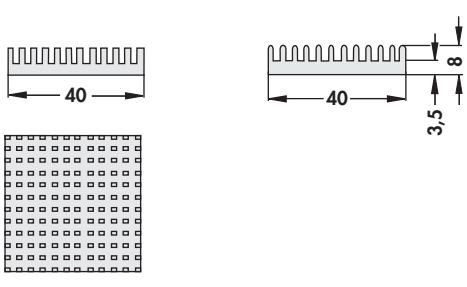
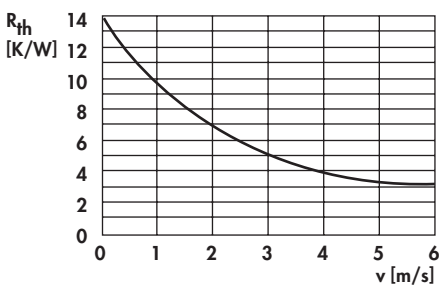
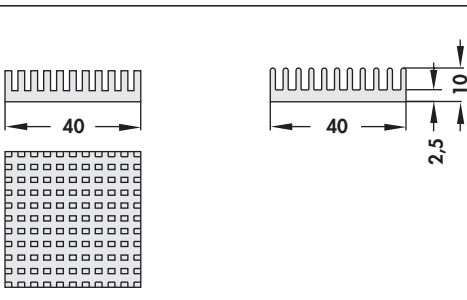
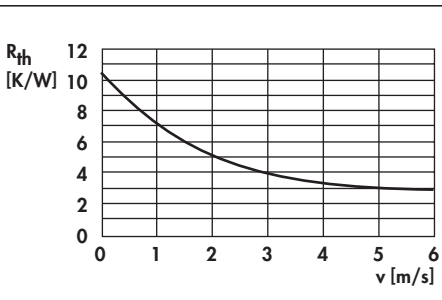
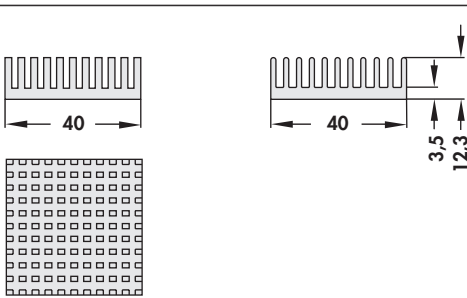
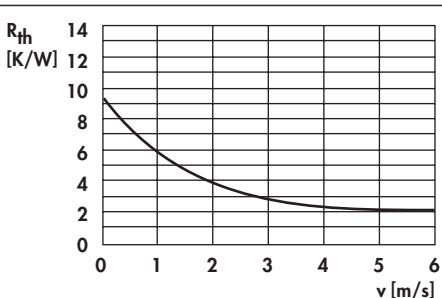
<p>art. no.</p> <p>ICK PGA 14 x 14 x 12 WLF ... 36 x 36</p>		
<p>art. no.</p> <p>ICK PGA 15 x 15 WLF ... 37 x 37</p>		
<p>art. no.</p> <p>ICK PGA 16 x 16 x 8 WLF ... 40 x 40</p>		
<p>art. no.</p> <p>ICK PGA 16 x 16 x 10 WLF ... 40 x 40</p>		
<p>art. no.</p> <p>ICK PGA 16 x 16 x 12 WLF ... 40 x 40</p>		
<p>surface:</p>		<p>black anodised</p>

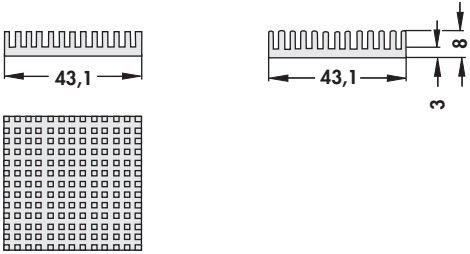
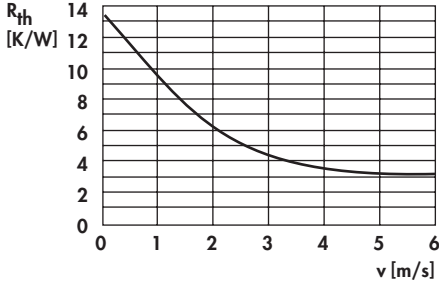
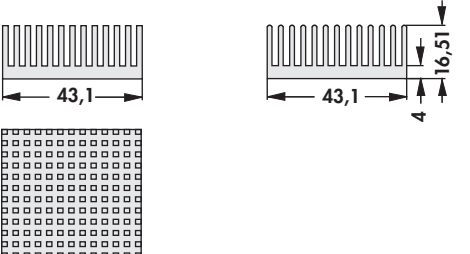
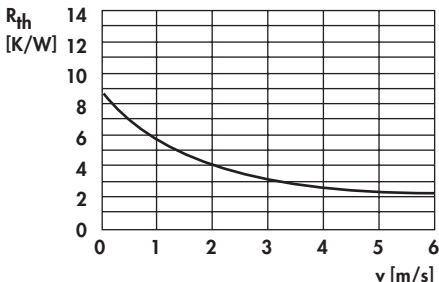
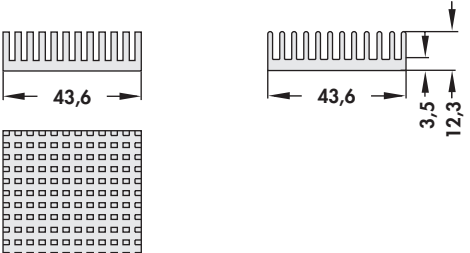
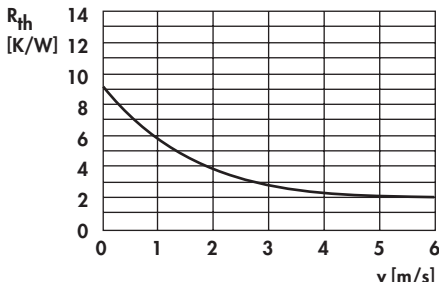
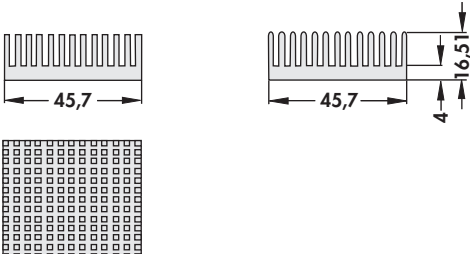
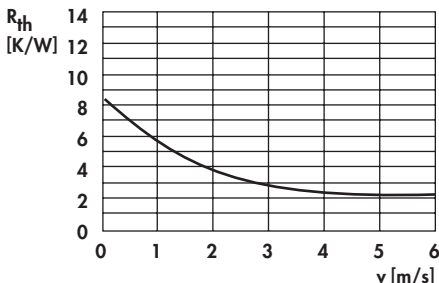
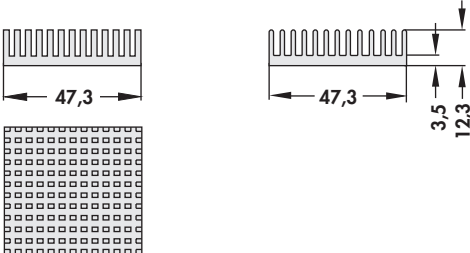
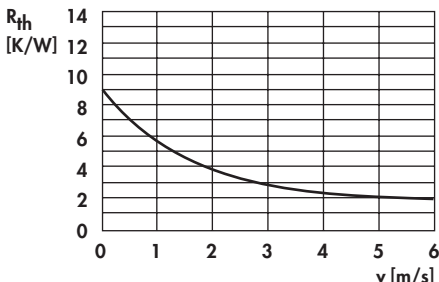
<p>art. no.</p> <p>ICK PGA 17 x 17 x 8 WLF ... 43 x 43</p>		
<p>art. no.</p> <p>ICK PGA 17 x 17 WLF ... 43 x 43</p>		
<p>art. no.</p> <p>ICK PGA 17 x 17 x 12 WLF ... 43 x 43</p>		
<p>art. no.</p> <p>ICK PGA 18 x 18 WLF ... 45 x 45</p>		
<p>art. no.</p> <p>ICK PGA 19 x 19 x 12 WLF ... 47 x 47</p>		
<p>surface: black anodised</p>		

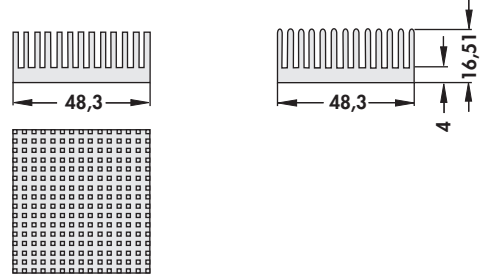
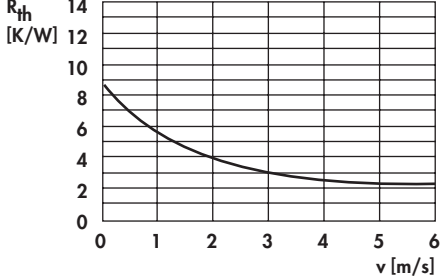
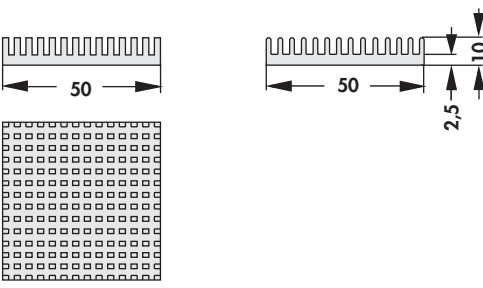
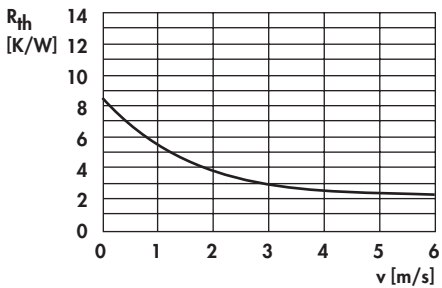
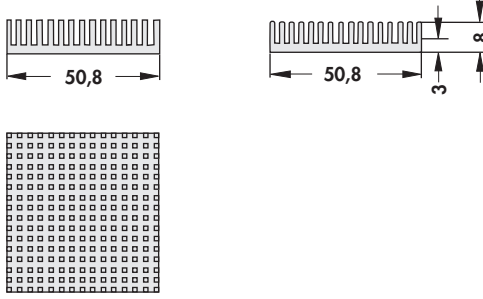
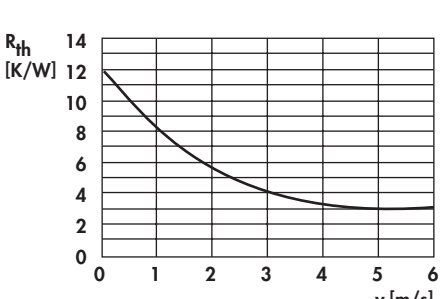
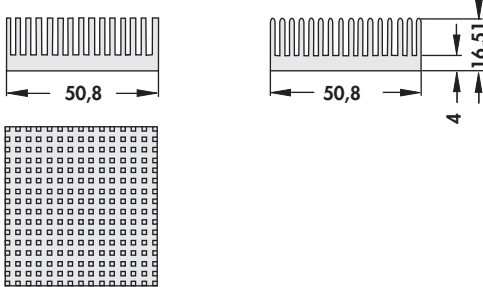
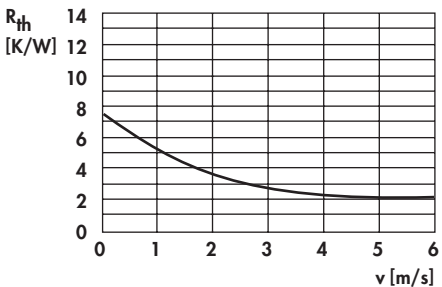
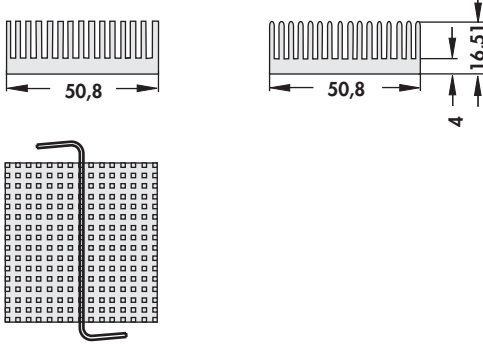
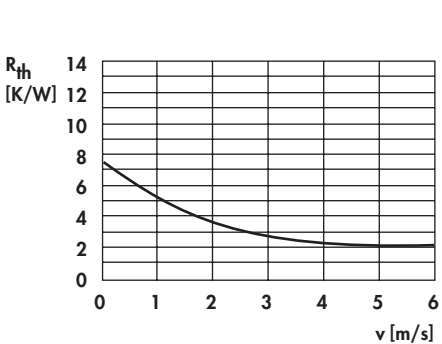
<p>art. no.</p> <p>ICK PGA 19 x 19 WLF ... 48 x 48</p>		
<p>art. no.</p> <p>ICK PGA 20 x 20 x 10 WLF ... 48 x 48</p>		
<p>art. no.</p> <p>ICK PGA 20 x 20 x 8 WLF ... 50 x 50</p>		
<p>art. no.</p> <p>ICK PGA 20 x 20 WLF ... 50 x 50</p>		
<p>art. no.</p> <p>ICK PGA 20 x 20 K WLF ... 50 x 50</p>		
<p>with fixing clamp for socket 7 and socket 370</p>		
<p>surface:</p>	<p>black anodised</p>	

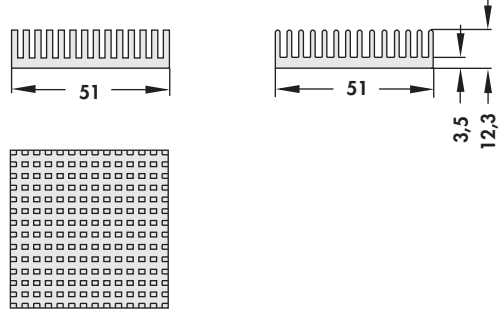
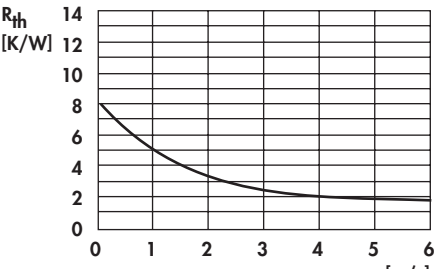
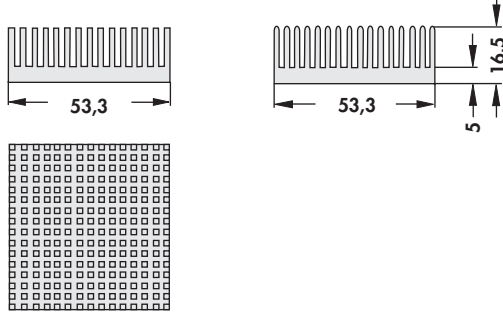
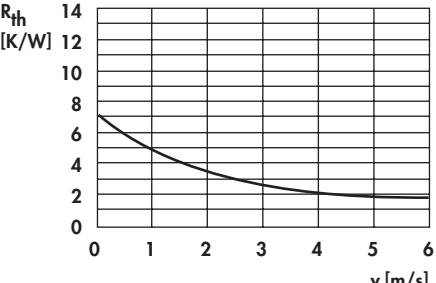
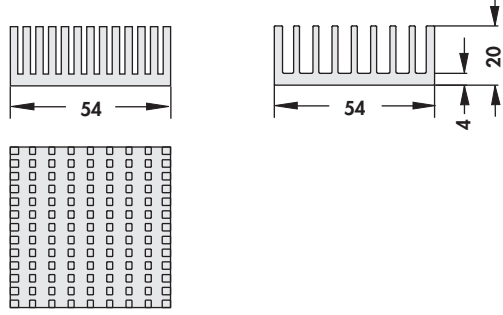
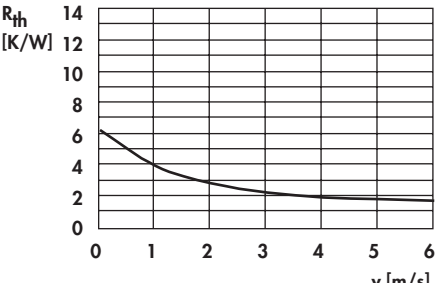
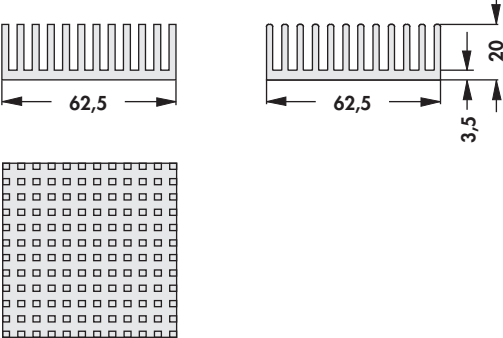
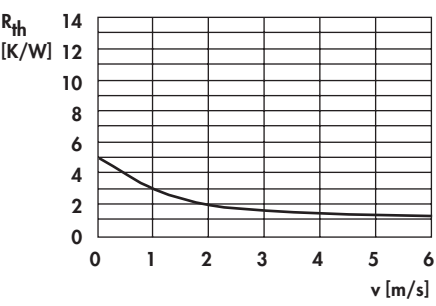
<p>art. no.</p> <p>ICK PGA 20 x 20 x 12 WLF ... 50 x 50</p>		
<p>art. no.</p> <p>ICK PGA 21 x 21 WLF ... 53 x 53</p>		
<p>art. no.</p> <p>ICK PGA 22 x 22 WLF ... 54 x 54</p>		
<p>art. no.</p> <p>ICK PGA 25 x 25 WLF ... 62 x 62</p>		
<p>surface:</p>		<p>black anodised</p>

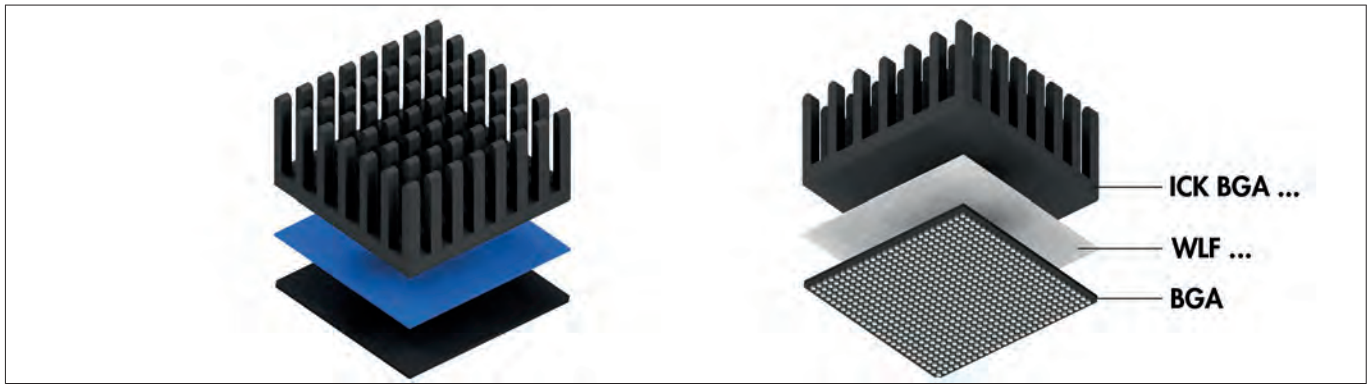

- particularly suited for **B**all **G**rid **A**rrays
- heatsink dimensions match the respective BGA-type
- can be glued directly on the BGA component
- double-sided adhesive thermal conductive foil **WLF ...** → E 39

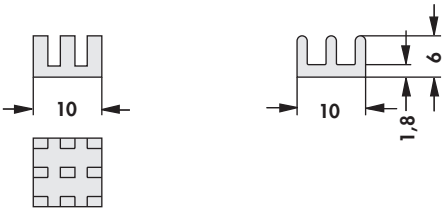
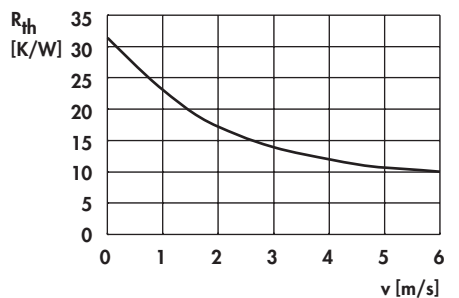
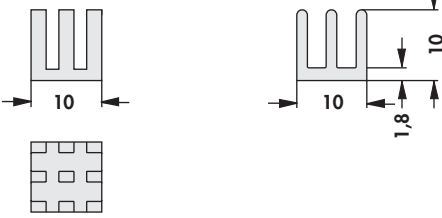
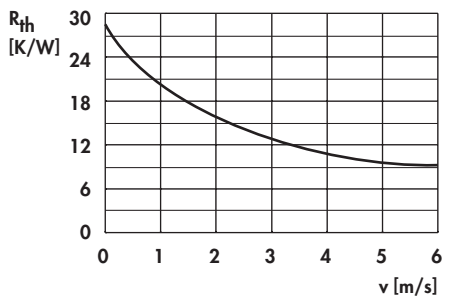
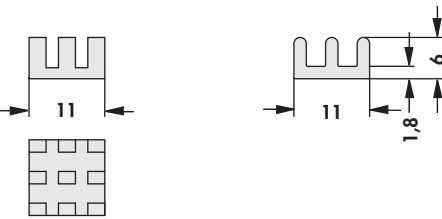
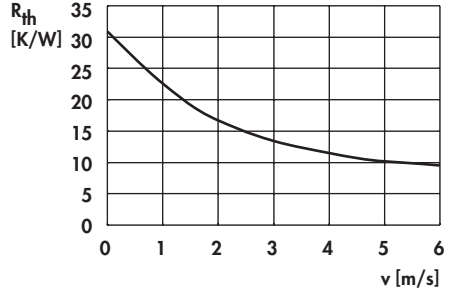
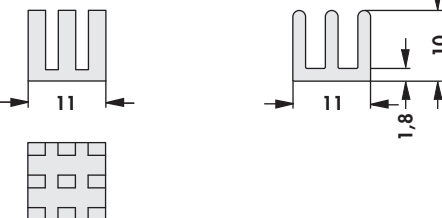
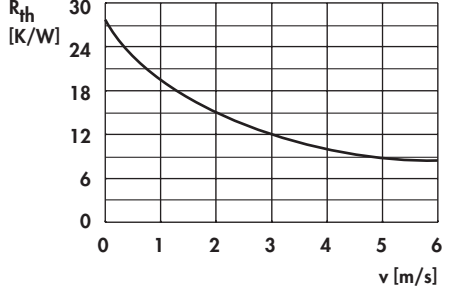
<p>art. no.</p> <p>ICK BGA 10 x 10 WLF ... 10 x 10</p>		
<p>art. no.</p> <p>ICK BGA 10 x 10 x 10 WLF ... 10 x 10</p>		
<p>art. no.</p> <p>ICK BGA 11 x 11 x 6 WLF ... 11 x 11</p>		
<p>art. no.</p> <p>ICK BGA 11 x 11 x 10 WLF ... 11 x 11</p>		
<p>surface:</p>		<p>black anodised</p>

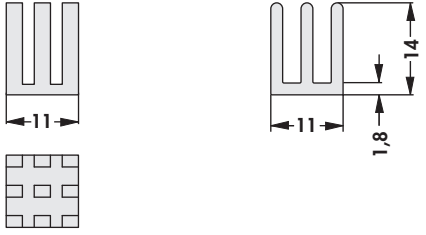
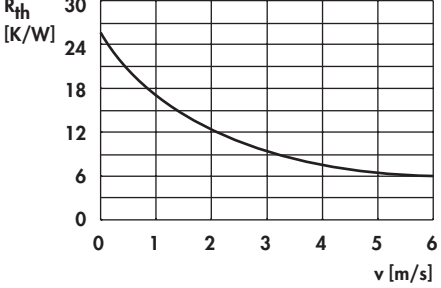
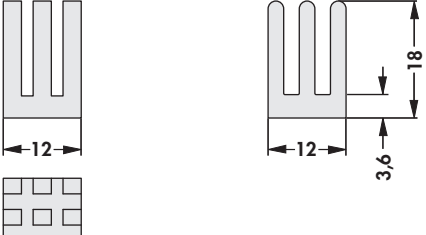
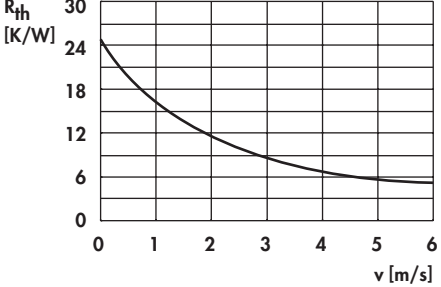
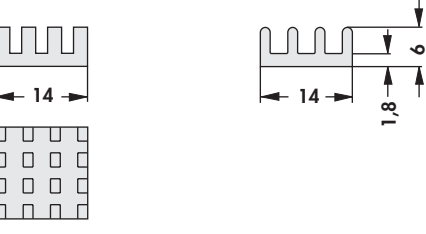
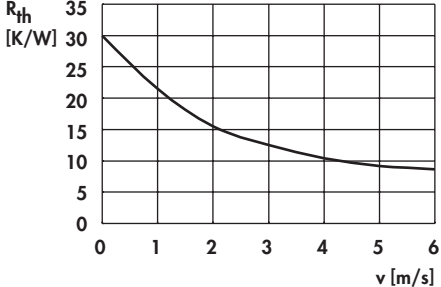
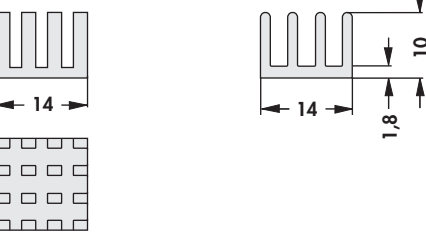
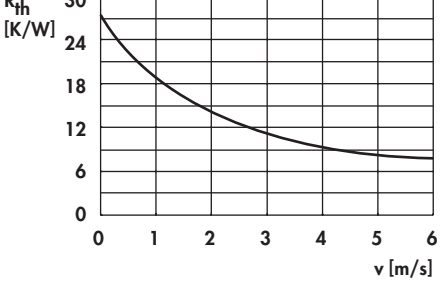
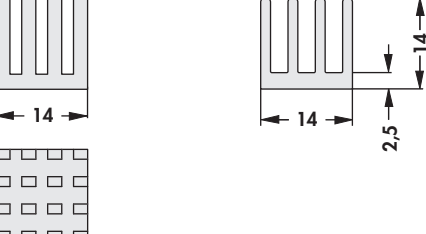
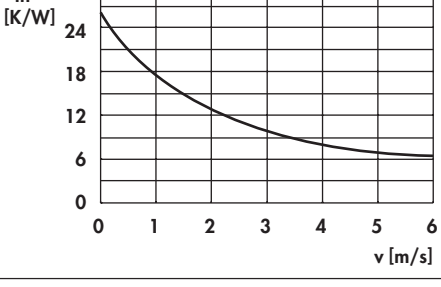
art. no. ICK BGA 11 x 11 x 14 WLF ... 11 x 11		
art. no. ICK BGA 12 x 12 x 18 WLF ... 12 x 12		
art. no. ICK BGA 14 x 14 WLF ... 14 x 14		
art. no. ICK BGA 14 x 14 x 10 WLF ... 14 x 14		
art. no. ICK BGA 14 x 14 x 14 WLF ... 14 x 14		
surface:		black anodised

<p>art. no.</p> <p>ICK BGA 15 x 15 x 6 WLF ... 15 x 15</p>		
<p>art. no.</p> <p>ICK BGA 15 x 15 x 10 WLF ... 15 x 15</p>		
<p>art. no.</p> <p>ICK BGA 15 x 15 x 14 WLF ... 15 x 15</p>		
<p>art. no.</p> <p>ICK BGA 19 x 19 x 6 WLF ... 19 x 19</p>		
<p>art. no.</p> <p>ICK BGA 19 x 19 x 10 WLF ... 19 x 19</p>		
<p>art. no.</p> <p>ICK BGA 19 x 19 x 14 WLF ... 19 x 19</p>		
<p>surface:</p>		<p>black anodised</p>

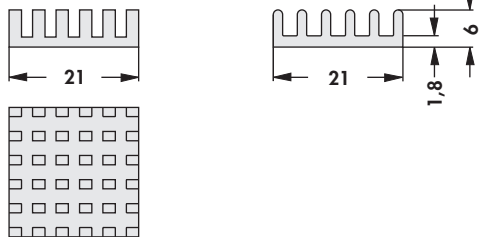
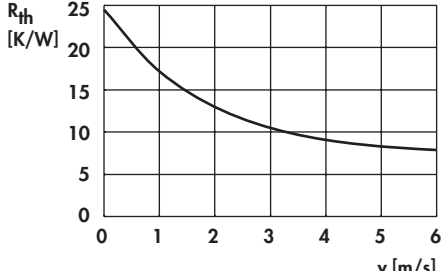
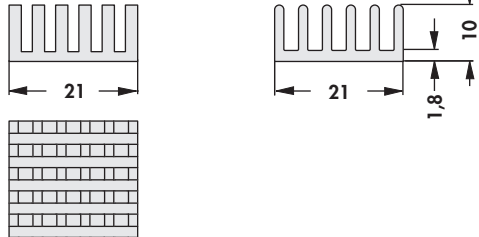
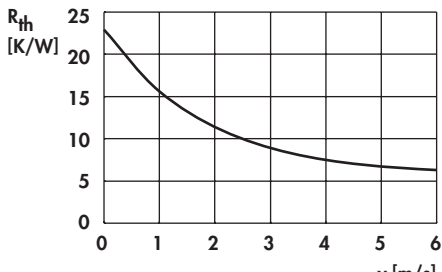
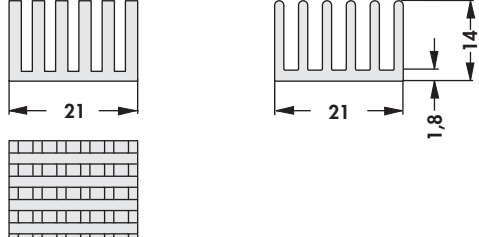
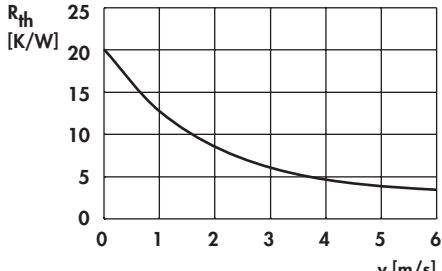
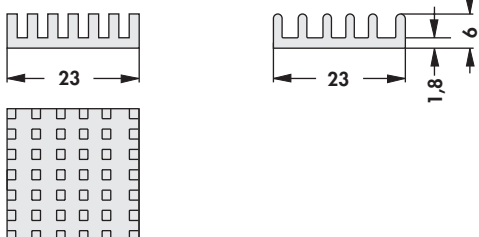
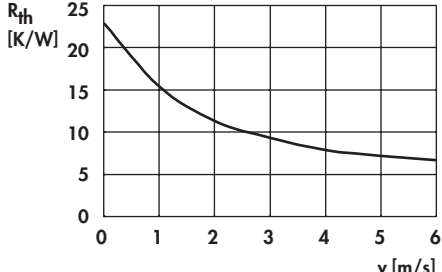
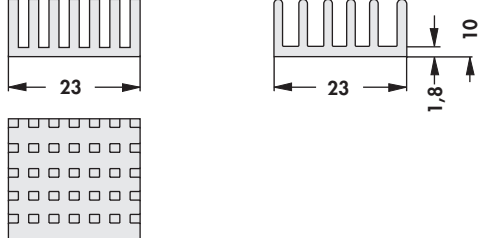
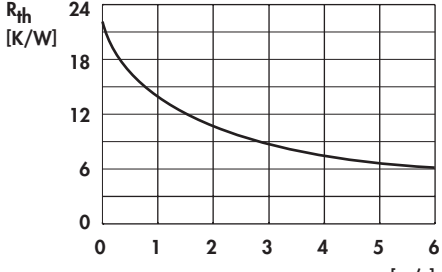
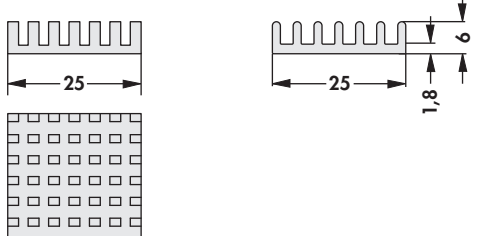
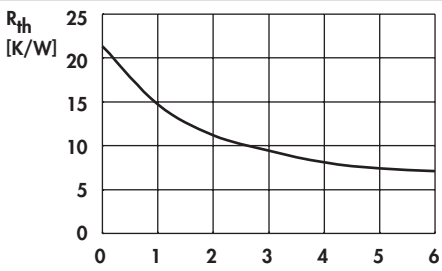
art. no. ICK BGA 21 x 21 WLF ... 21 x 21		
art. no. ICK BGA 21 x 21 x 10 WLF ... 21 x 21		
art. no. ICK BGA 21 x 21 x 14 WLF ... 21 x 21		
art. no. ICK BGA 23 x 23 WLF ... 23 x 23		
art. no. ICK BGA 23 x 23 x 10 WLF ... 23 x 23		
art. no. ICK BGA 25 x 25 x 6 WLF ... 25 x 25		
surface:		black anodised

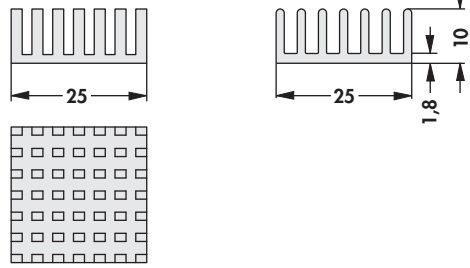
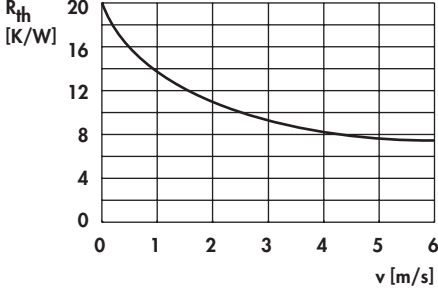
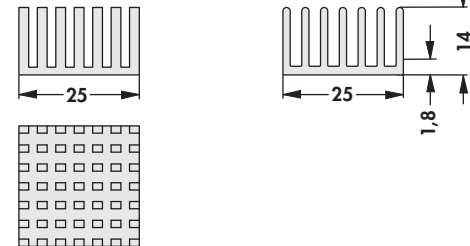
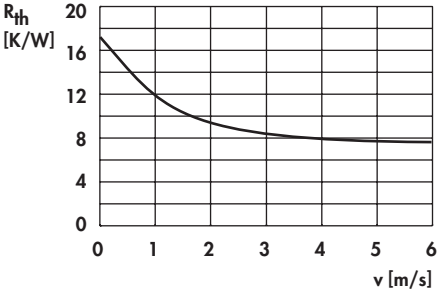
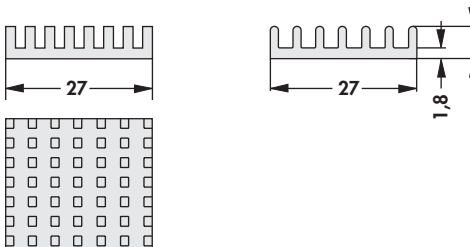
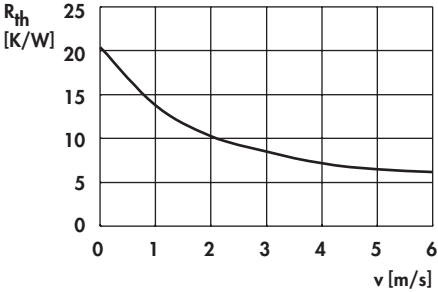
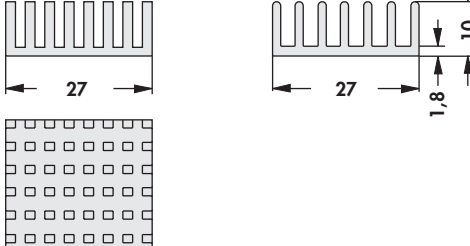
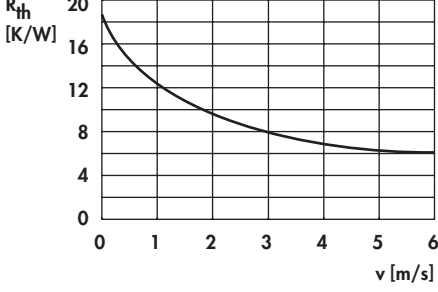
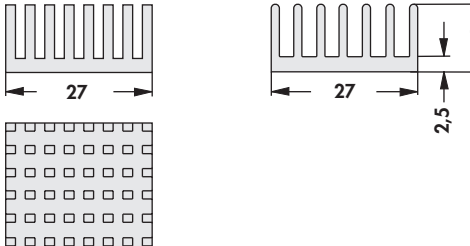
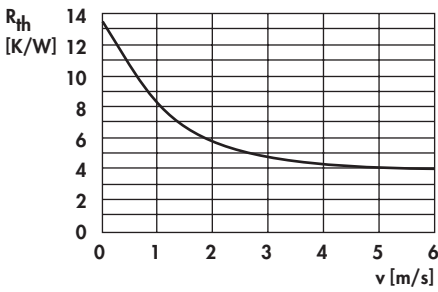
<p>art. no.</p> <p>ICK BGA 25 x 25 x 10 WLF ... 25 x 25</p>		
<p>art. no.</p> <p>ICK BGA 25 x 25 x 14 WLF ... 25 x 25</p>		
<p>art. no.</p> <p>ICK BGA 27 x 27 WLF ... 27 x 27</p>		
<p>art. no.</p> <p>ICK BGA 27 x 27 x 10 WLF ... 27 x 27</p>		
<p>art. no.</p> <p>ICK BGA 27 x 27 x 14 WLF ... 27 x 27</p>		
<p>surface:</p>		<p>black anodised</p>

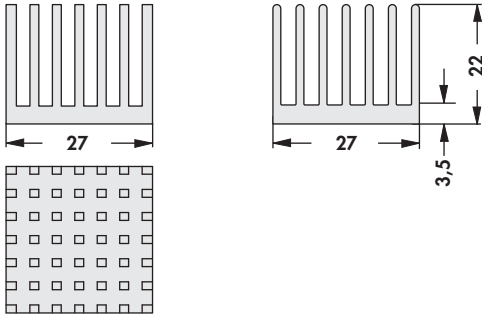
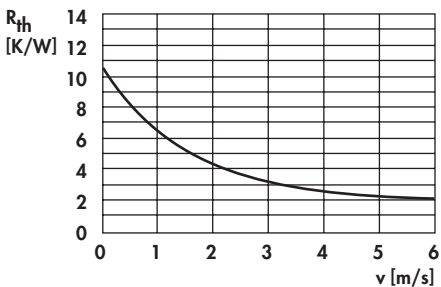
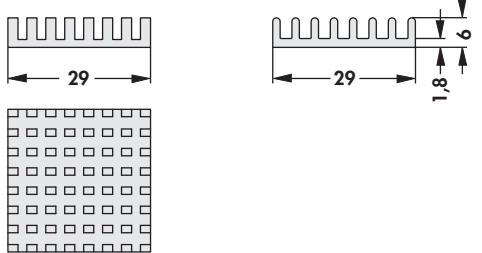
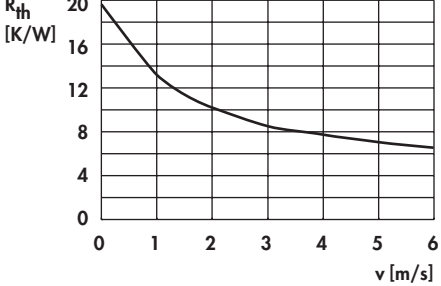
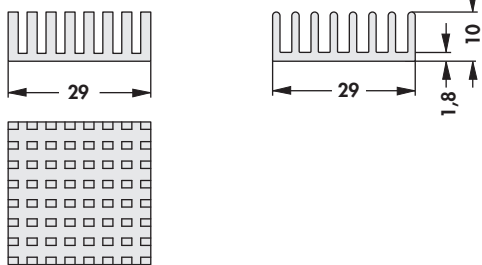
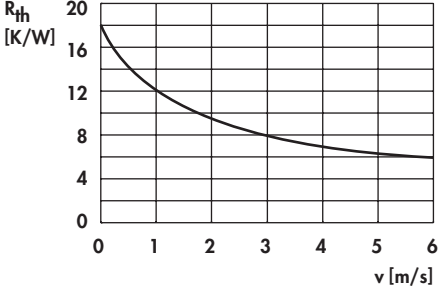
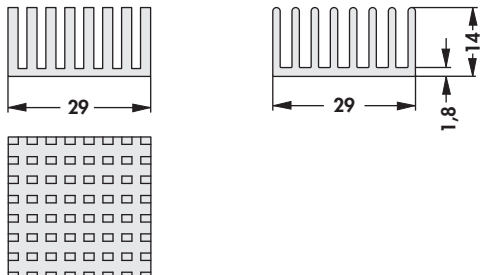
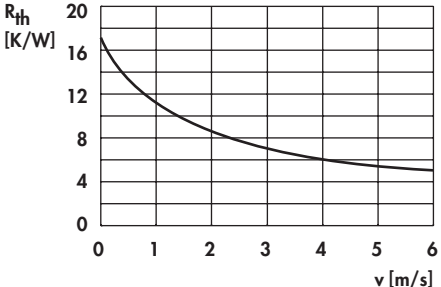
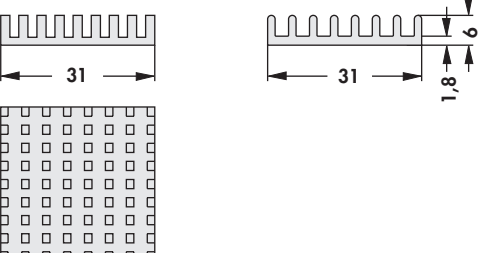
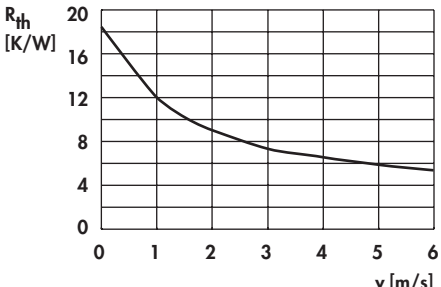
<p>art. no.</p> <p>ICK BGA 27 x 27 x 22 WLF ... 27 x 27</p>		
<p>art. no.</p> <p>ICK BGA 29 x 29 x 6 WLF ... 29 x 29</p>		
<p>art. no.</p> <p>ICK BGA 29 x 29 x 10 WLF ... 29 x 29</p>		
<p>art. no.</p> <p>ICK BGA 29 x 29 x 14 WLF ... 29 x 29</p>		
<p>art. no.</p> <p>ICK BGA 31 x 31 WLF ... 31 x 31</p>		
<p>surface:</p>		<p>black anodised</p>

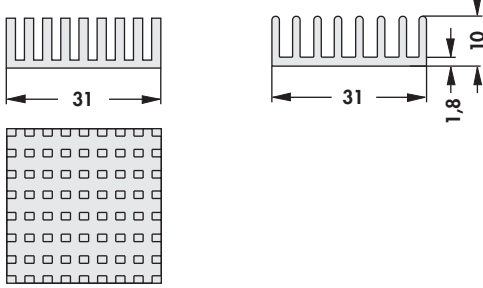
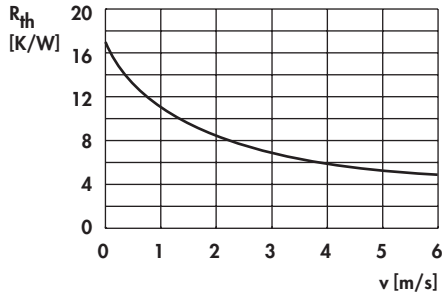
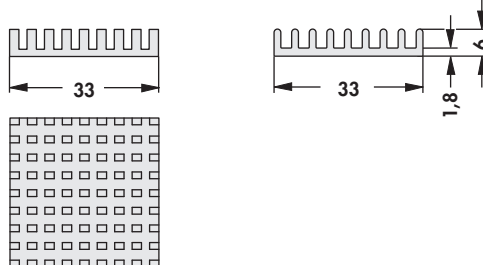
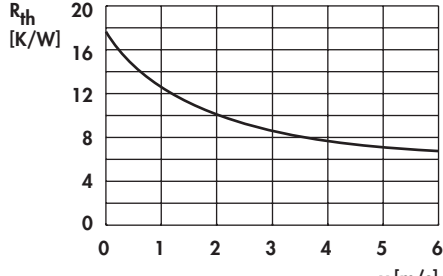
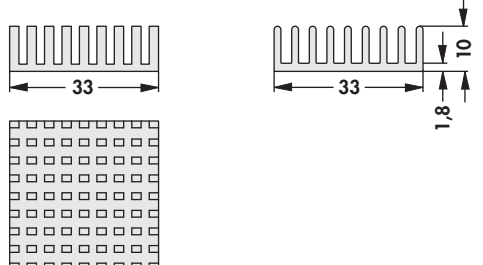
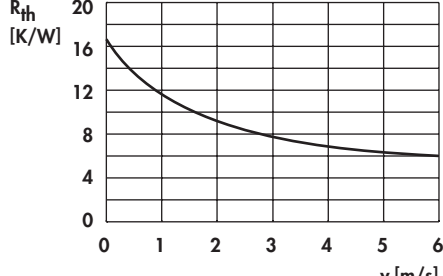
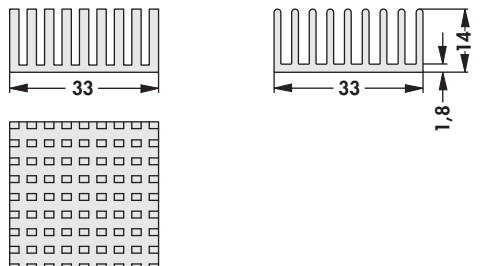
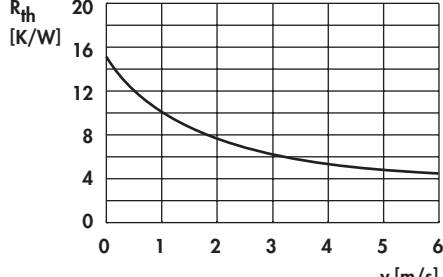
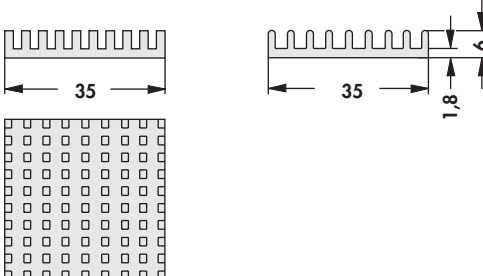
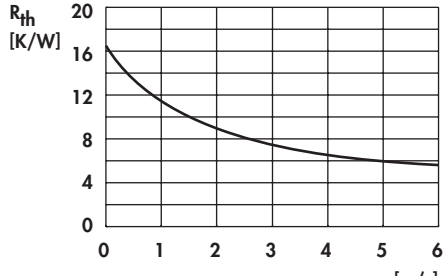
<p>art. no.</p> <p>ICK BGA 31 x 31 x 10 WLF ... 31 x 31</p>		
<p>art. no.</p> <p>ICK BGA 33 x 33 x 6 WLF ... 33 x 33</p>		
<p>art. no.</p> <p>ICK BGA 33 x 33 x 10 WLF ... 33 x 33</p>		
<p>art. no.</p> <p>ICK BGA 33 x 33 x 14 WLF ... 33 x 33</p>		
<p>art. no.</p> <p>ICK BGA 35 x 35 WLF ... 35 x 35</p>		
<p>surface:</p>		<p>black anodised</p>

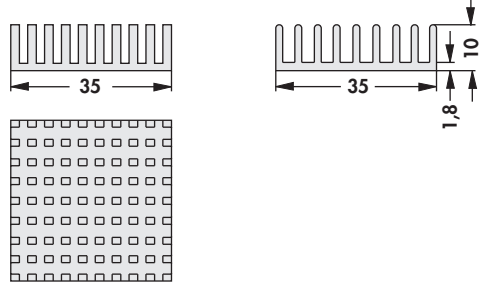
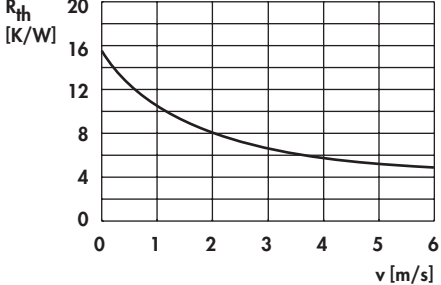
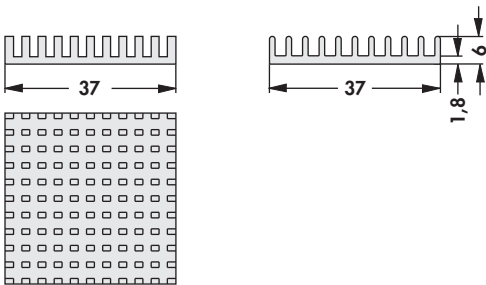
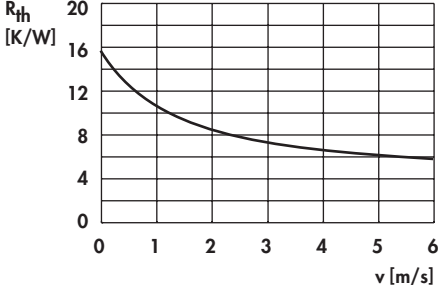
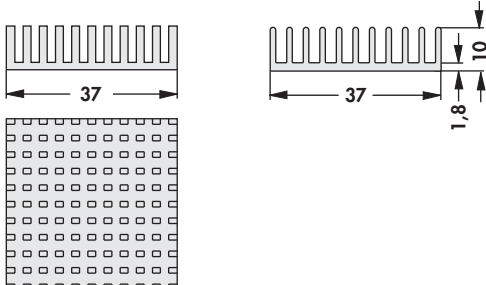
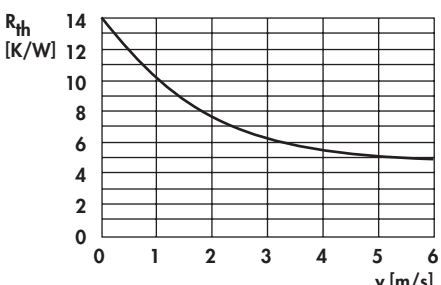
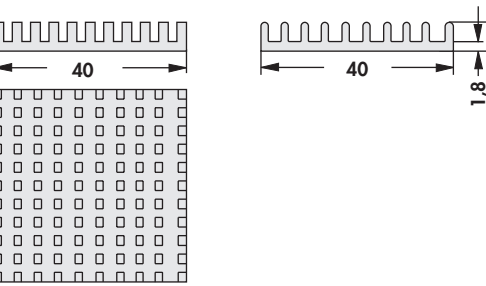
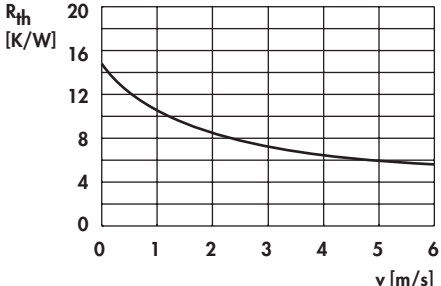
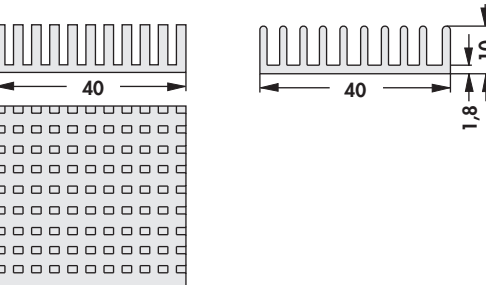
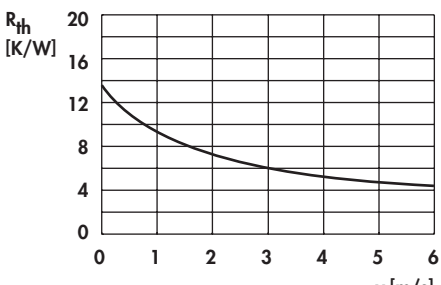
art. no. ICK BGA 35 x 35 x 10 WLF ... 35 x 35		
art. no. ICK BGA 37 x 37 x 6 WLF ... 37 x 37		
art. no. ICK BGA 37 x 37 x 10 WLF ... 37 x 37		
art. no. ICK BGA 40 x 40 WLF ... 40 x 40		
art. no. ICK BGA 40 x 40 x 10 WLF ... 40 x 40		
surface:		black anodised

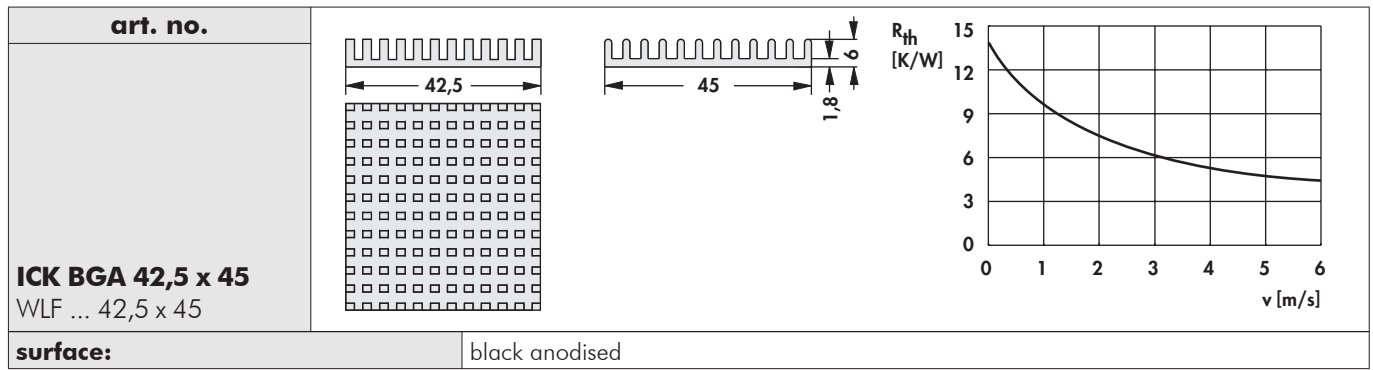

Pin heatsinks rectangle

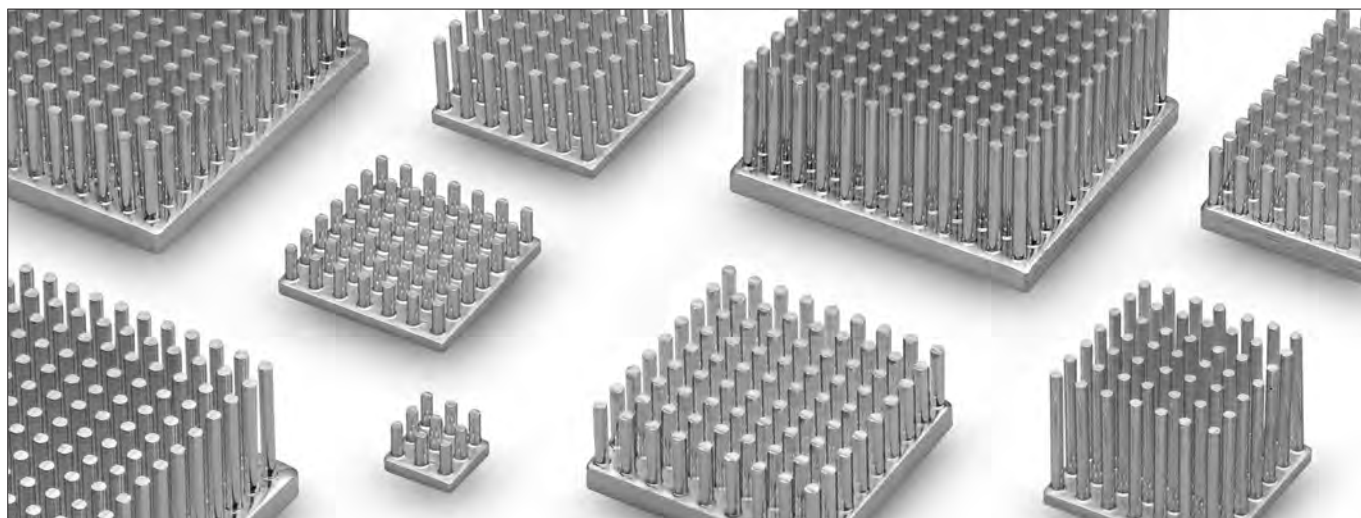

- arrangement and number of pins for optimum air flow
- suitable for forced and free convection
- excellent thermal conductivity by the alloy material (EN AW 1050 A; 220 W/mK) and homogeneous arrangement of materials
- constant heat dissipation in the base and the pins in the direction of heat flow
- low weight achieved by optimised geometry
- components fastened using glue, adhesive foil or clamps
- customer-specific modifications and special designs; other pin-lengths and surfaces on request

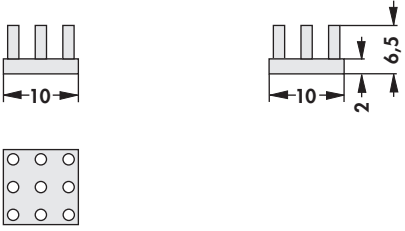
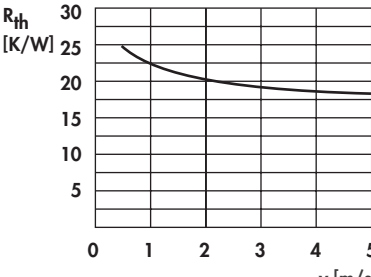
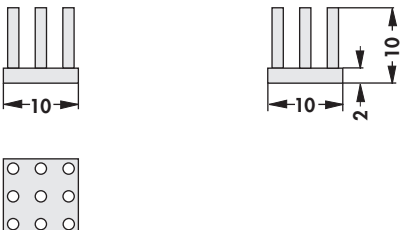
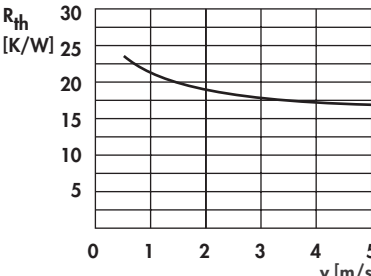
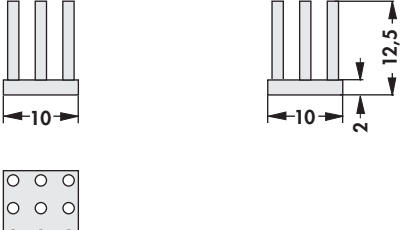
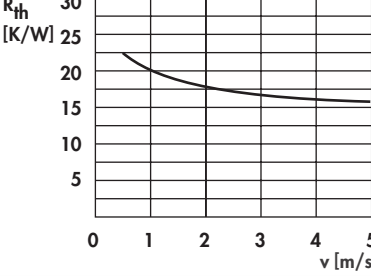
<p>art. no.</p> <p>ICK S 10 x 10 x 6,5 WLF ... 10 x 10 weight: 1g</p>		
<p>art. no.</p> <p>ICK S 10 x 10 x 10 WLF ... 10 x 10 weight: 1g</p>		
<p>art. no.</p> <p>ICK S 10 x 10 x 12,5 WLF ... 10 x 10 weight: 1.3g</p>		
<p>surface:</p>		<p>Al-natural</p>

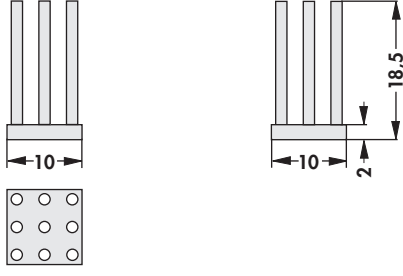
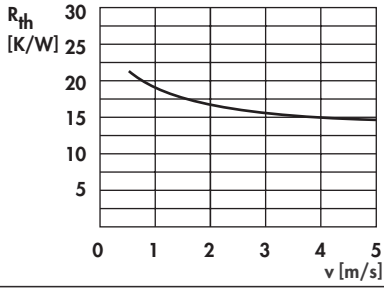
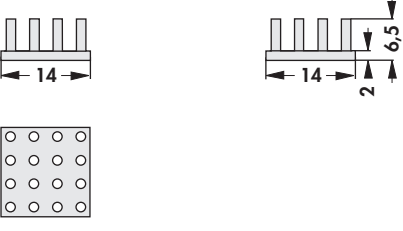
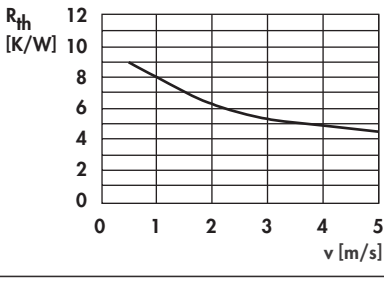
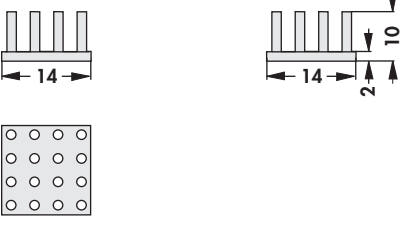
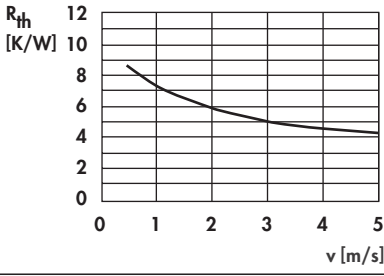
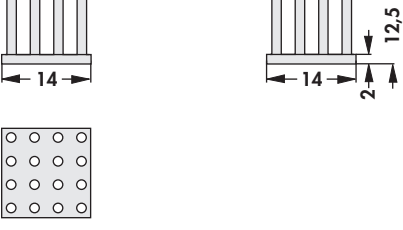
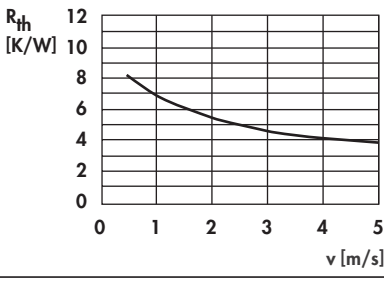
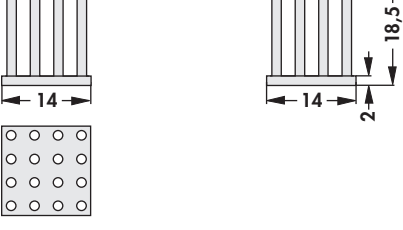
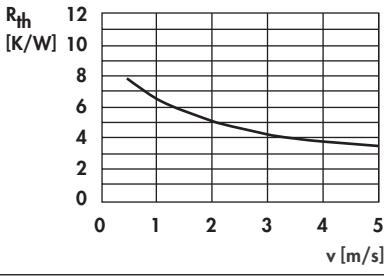
<p>art. no.</p> <p>ICK S 10 x 10 x 18,5 WLF ... 10 x 10 weight: 1.3g</p>		
<p>art. no.</p> <p>ICK S 14 x 14 x 6,5 WLF ... 14 x 14 weight: 1.5g</p>		
<p>art. no.</p> <p>ICK S 14 x 14 x 10 WLF ... 14 x 14 weight: 1.9g</p>		
<p>art. no.</p> <p>ICK S 14 x 14 x 12,5 WLF ... 14 x 14 weight: 2g</p>		
<p>art. no.</p> <p>ICK S 14 x 14 x 18,5 WLF ... 14 x 14 weight: 2.4g</p>		
<p>surface:</p>		<p>Al-natural</p>

Pin heatsinks

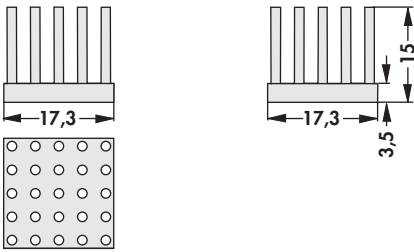
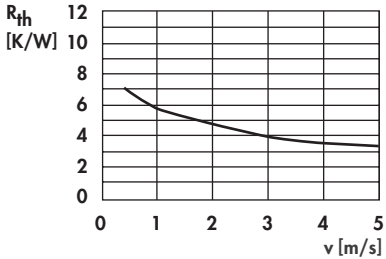
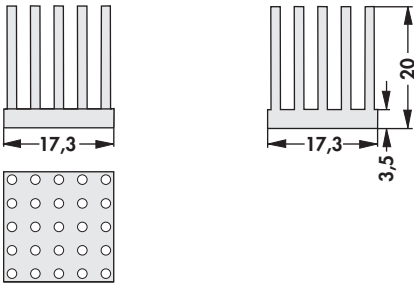
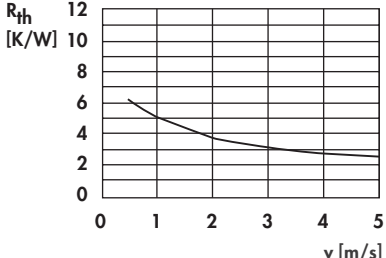
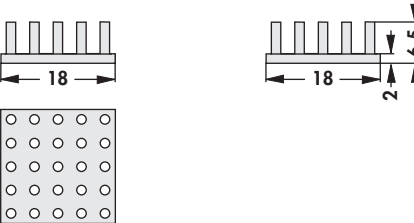
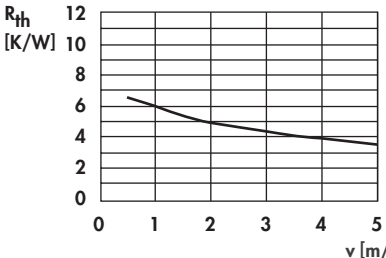
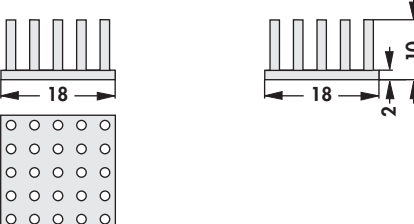
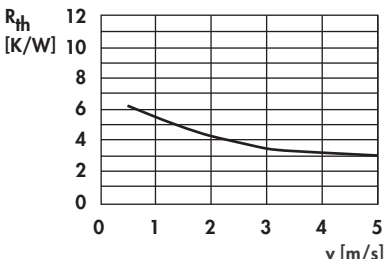
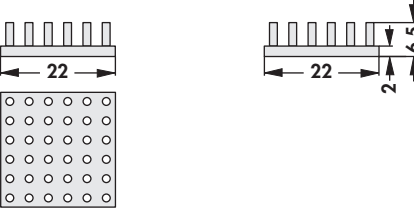
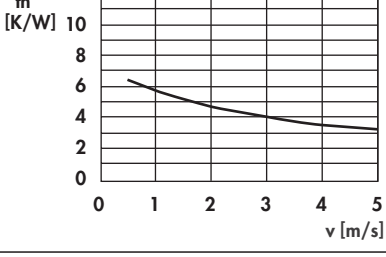
<p>art. no.</p> <p>ICK S 17 x 17 x 15 WLF ... 17 x 17 weight: 4.7g</p>		
<p>art. no.</p> <p>ICK S 17 x 17 x 20 WLF ... 17 x 17 weight: 5.6g</p>		
<p>art. no.</p> <p>ICK S 18 x 18 x 6,5 WLF ... 18 x 18 weight: 2.5g</p>		
<p>art. no.</p> <p>ICK S 18 x 18 x 10 WLF ... 18 x 18 weight: 3.1g</p>		
<p>art. no.</p> <p>ICK S 22 x 22 x 6,5 weight: 3.5g</p>		
<p>surface:</p>		<p>Al-natural</p>

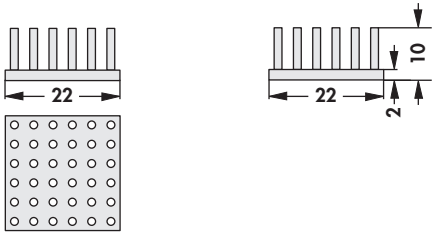
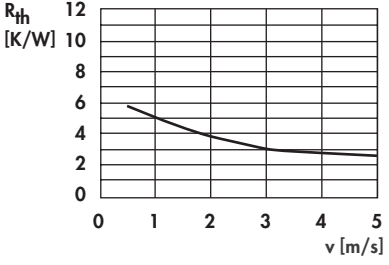
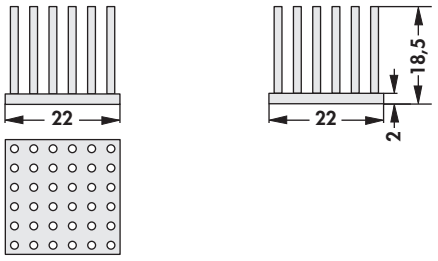
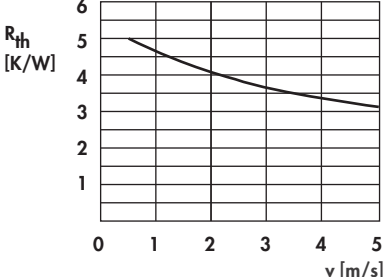
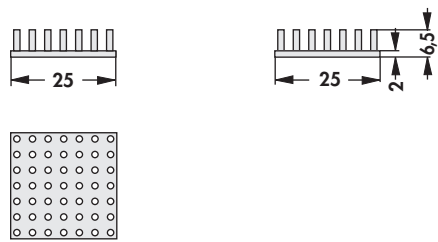
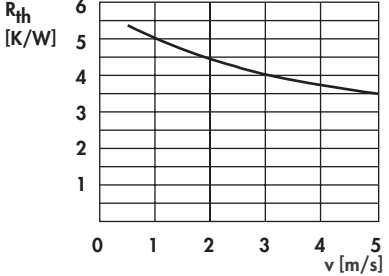
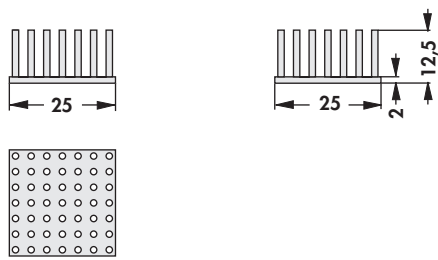
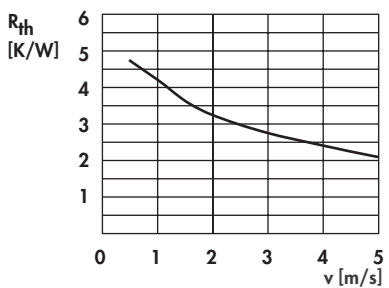
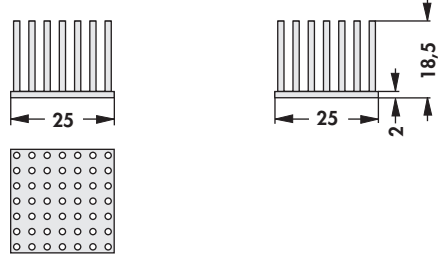
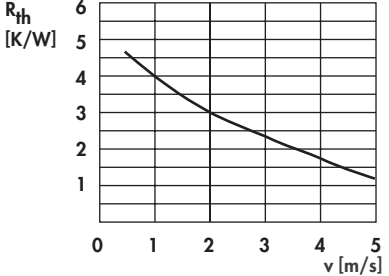
<p>art. no.</p> <p>ICK S 22 x 22 x 10 WLF ... 22 x 22 weight: 4g</p>		
<p>art. no.</p> <p>ICK S 22 x 22 x 18,5 WLF ... 22 x 22 weight: 5.4g</p>		
<p>art. no.</p> <p>ICK S 25 x 25 x 6,5 WLF ... 25 x 25 weight: 4g</p>		
<p>art. no.</p> <p>ICK S 25 x 25 x 12,5 WLF ... 25 x 25 weight: 6g</p>		
<p>art. no.</p> <p>ICK S 25 x 25 x 18,5 WLF ... 25 x 25 weight: 7g</p>		
<p>surface:</p>		<p>Al-natural</p>

Pin heatsinks

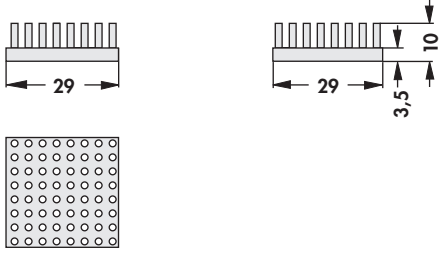
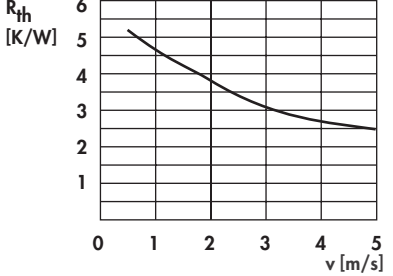
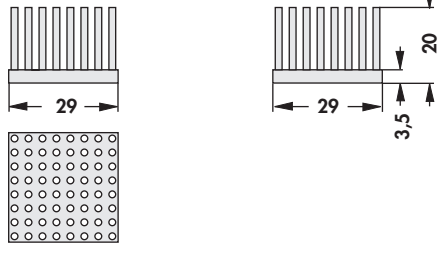
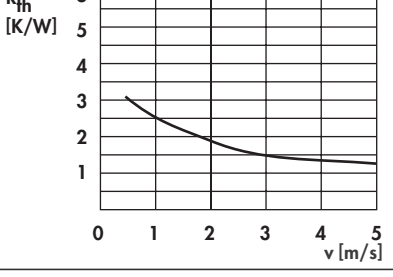
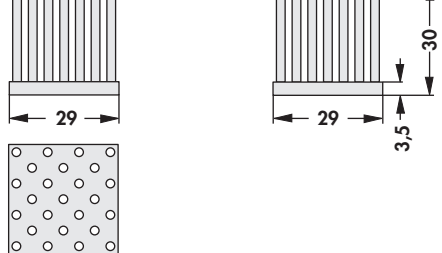
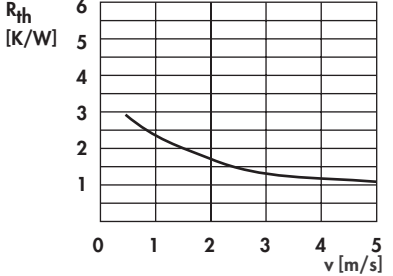
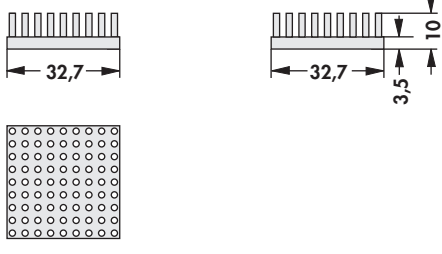
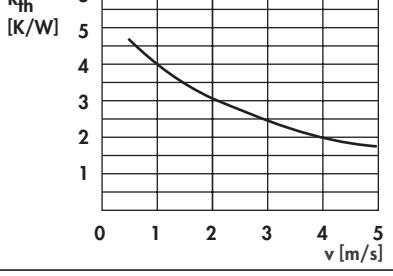
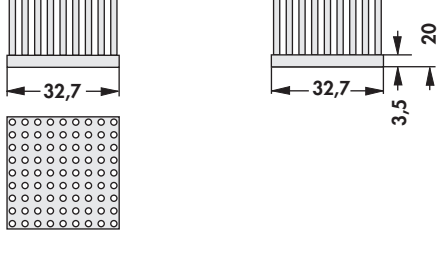
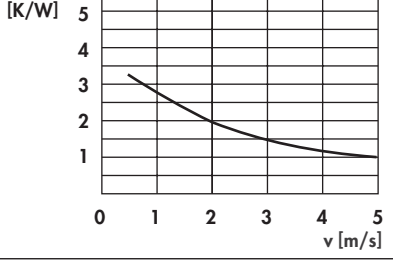
<p>art. no.</p> <p>ICK S 29 x 29 x 10 WLF ... 29 x 29 weight: 11g</p>		
<p>art. no.</p> <p>ICK S 29 x 29 x 20 WLF ... 29 x 29 weight: 15g</p>		
<p>art. no.</p> <p>ICK S 29 x 29 x 30 WLF ... 29 x 29 weight: 15.4g</p>		
<p>art. no.</p> <p>ICK S 32 x 32 x 10 WLF ... 32 x 32 weight: 14g</p>		
<p>art. no.</p> <p>ICK S 32 x 32 x 20 WLF ... 32 x 32 weight: 19g</p>		
<p>surface:</p>		<p>Al-natural</p>

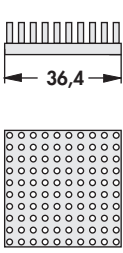
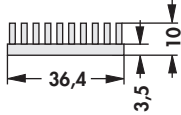
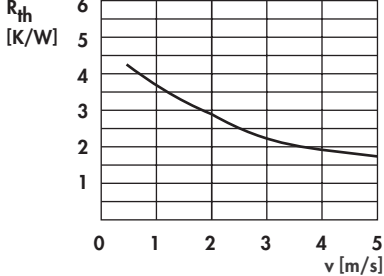
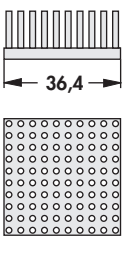
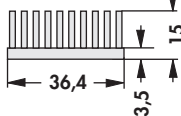
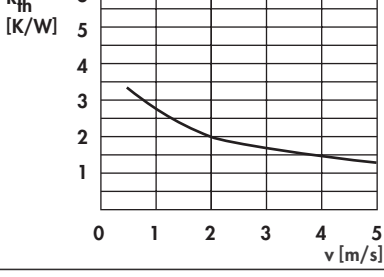
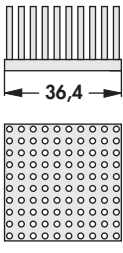
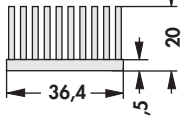
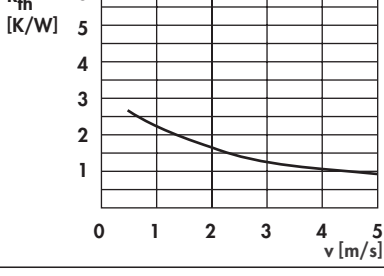
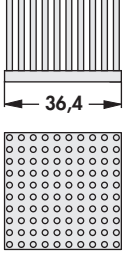
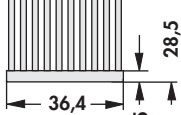
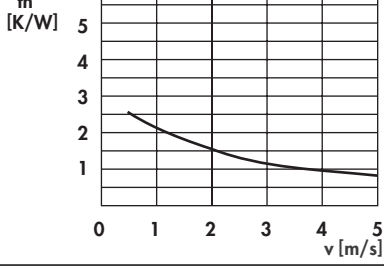
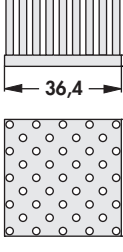
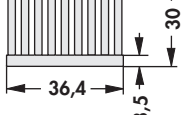
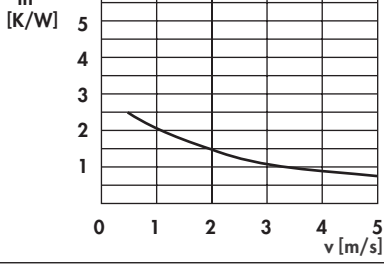
<p>art. no.</p> <p>ICK S 36 x 36 x 10 WLF ... 36 x 36 weight: 17g</p>			
<p>art. no.</p> <p>ICK S 36 x 36 x 15 WLF ... 36 x 36 weight: 20g</p>			
<p>art. no.</p> <p>ICK S 36 x 36 x 20 WLF ... 36 x 36 weight: 24g</p>			
<p>art. no.</p> <p>ICK S 36 x 36 x 28,5 weight: 30g</p>			
<p>art. no.</p> <p>ICK S 36 x 36 x 30 WLF ... 36 x 36 weight: 24.4g</p>			
<p>surface:</p>		<p>Al-natural</p>	

Pin heatsinks

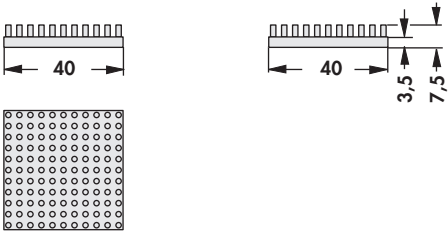
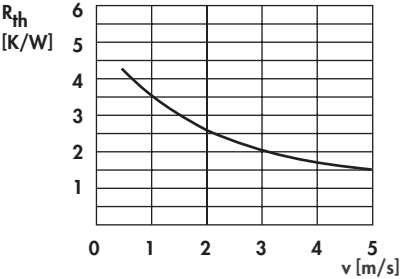
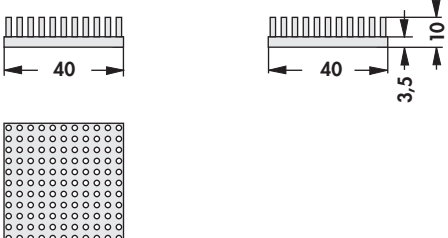
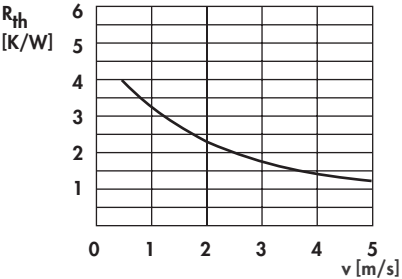
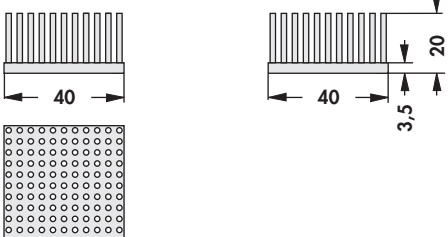
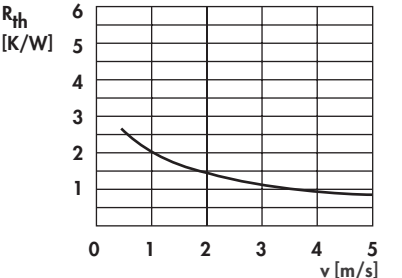
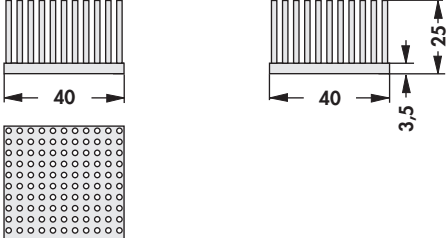
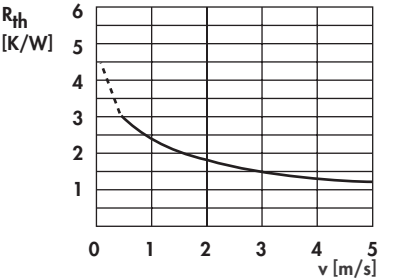
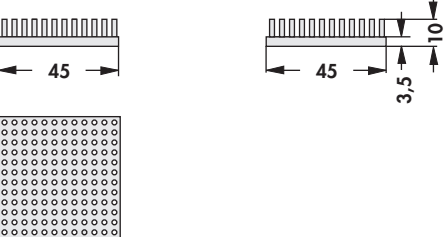
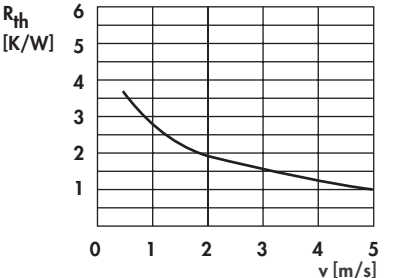
<p>art. no.</p> <p>ICK S 40 x 40 x 7,5 WLF ... 40 x 40 weight: 18g</p>		
<p>art. no.</p> <p>ICK S 40 x 40 x 10 WLF ... 40 x 40 weight: 21g</p>		
<p>art. no.</p> <p>ICK S 40 x 40 x 20 WLF ... 40 x 40 weight: 29g</p>		
<p>art. no.</p> <p>ICK S 40 x 40 x 25 WLF ... 40 x 40 weight: 37g</p>		
<p>art. no.</p> <p>ICK S 45 x 45 x 10 WLF ... 45 x 45 weight: 26g</p>		
<p>surface:</p>		<p>Al-natural</p>

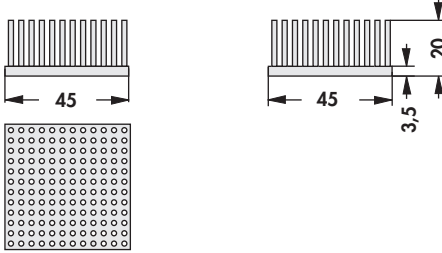
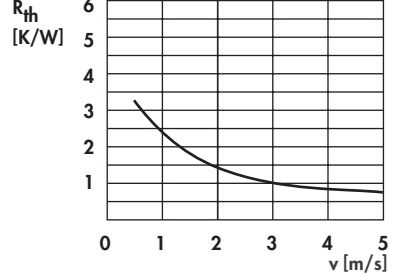
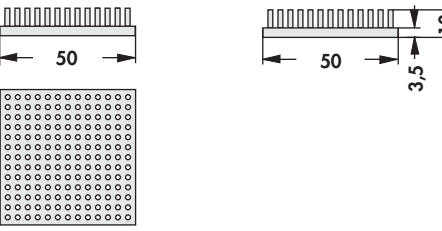
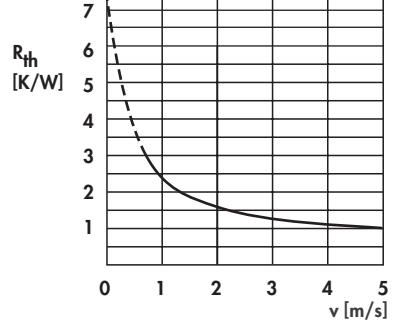
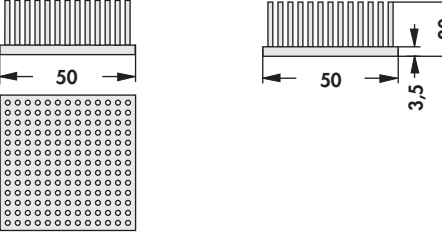
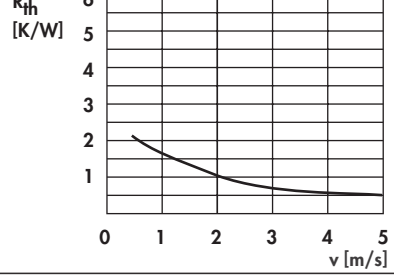
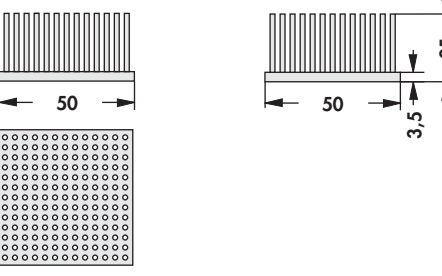
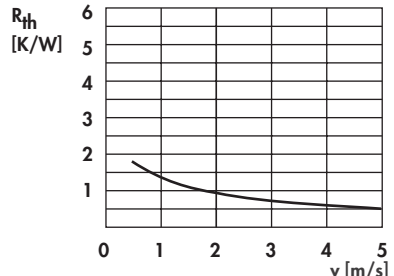
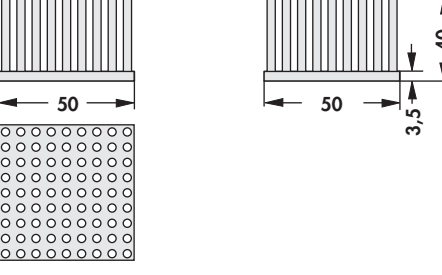
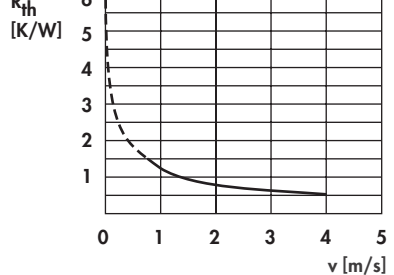

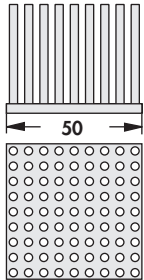
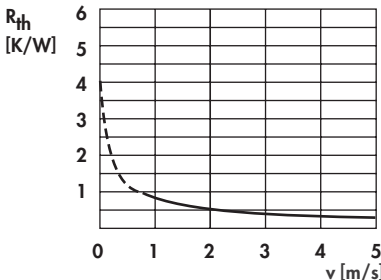
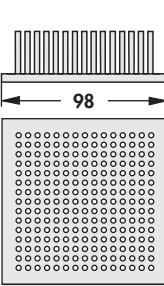
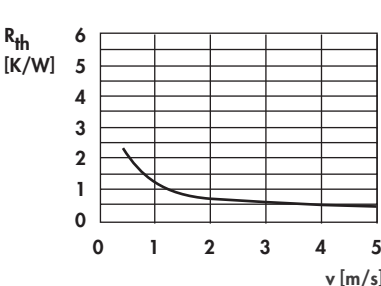
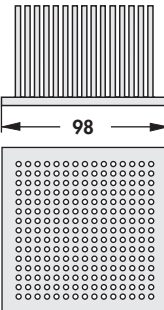
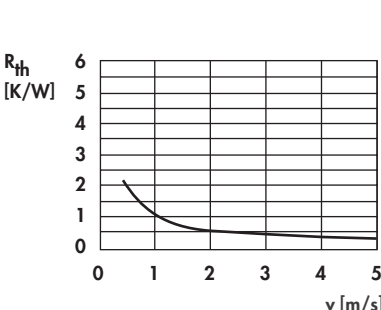

<p>art. no.</p> <p>ICK S 45 x 45 x 20 WLF ... 45 x 45 weight: 36g</p>		
<p>art. no.</p> <p>ICK S 50 x 50 x 10 WLF ... 50 x 50 weight: 31.2g</p>		
<p>art. no.</p> <p>ICK S 50 x 50 x 20 WLF ... 50 x 50 weight: 43g</p>		
<p>art. no.</p> <p>ICK S 50 x 50 x 25 WLF ... 50 x 50 weight: 49g</p>		
<p>art. no.</p> <p>ICK S 50 x 50 x 40 WLF ... 50 x 50 weight: 80g</p>		
<p>surface:</p>		<p>Al-natural</p>

Pin heatsinks

<p>art. no.</p> <p>ICK S 50 x 50 x 50 WLF ... 50 x 50 weight: 95g</p>		
<p>art. no.</p> <p>ICK S 98 x 98 x 30 WLF ... 98 x 98 weight: 237g</p>		
<p>art. no.</p> <p>ICK S 98 x 98 x 45 WLF ... 98 x 98 weight: 301.3g</p>		
<p>surface:</p>		<p>Al-natural</p>

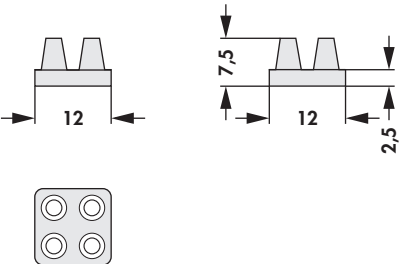
Pin heatsinks Dome

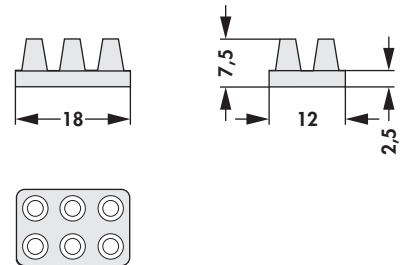
- double-sided adhesive thermal conductive foil **WLF ...** → E 39 - E 42

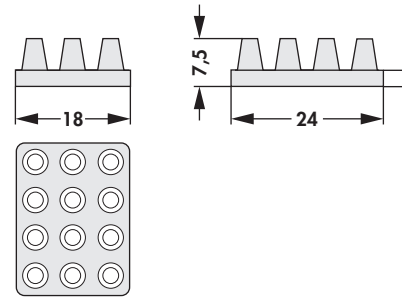
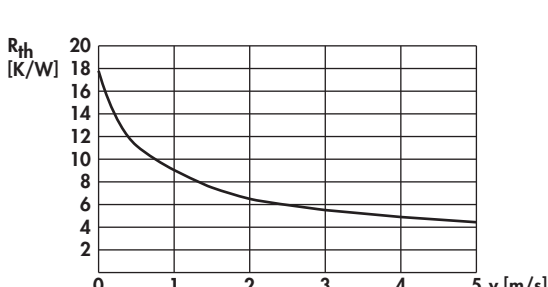
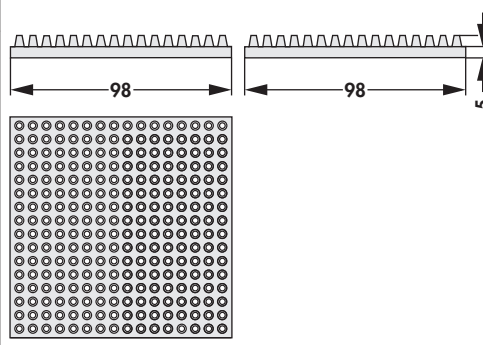
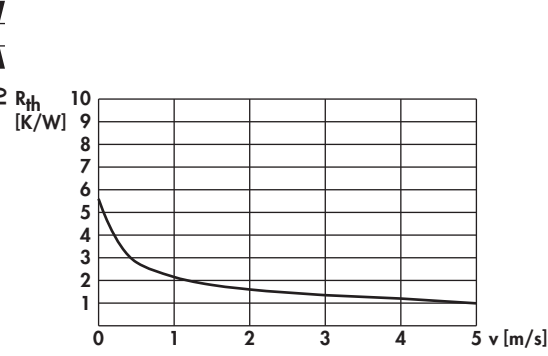
<p>art. no.</p> <p>ICK S D 12 x 12 x 7,5 WLF ... 12 x 12 weight: 1.8g</p>		
<p>art. no.</p> <p>ICK S D 18 x 12 x 7,5 WLF ... 12 x 18 weight: 2.7g</p>		
<p>art. no.</p> <p>ICK S D 24 x 18 x 7,5 WLF ... 18 x 24 weight: 4.4g</p>		
<p>art. no.</p> <p>ICK S D 98 x 98 x 10 WLF ... 98 x 98 weight: 154g</p> <p>surface:</p>		
<p>Al-natural</p>		





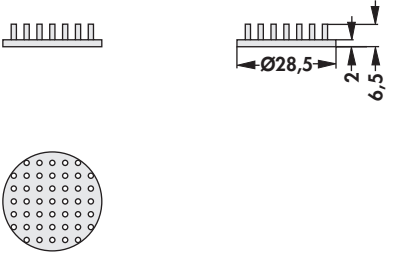
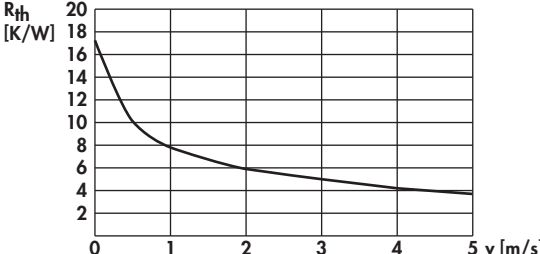
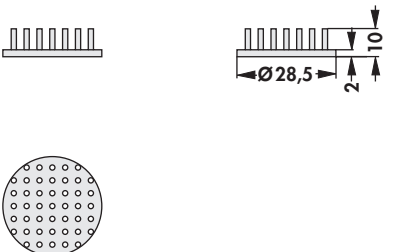
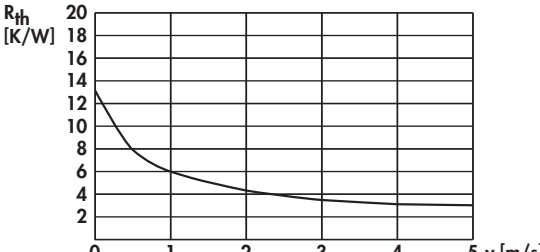
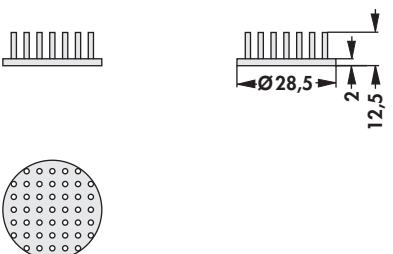
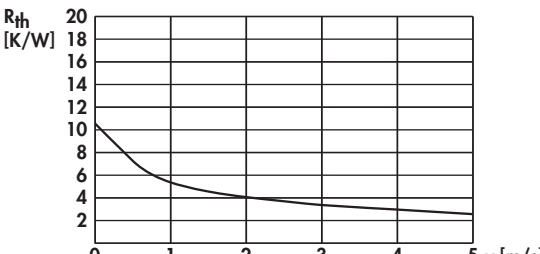

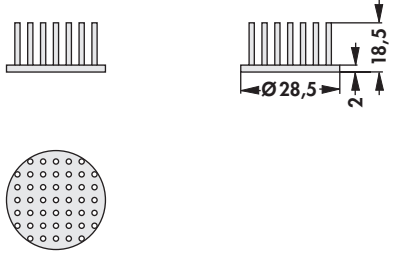
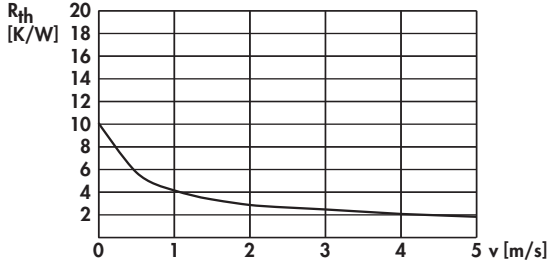
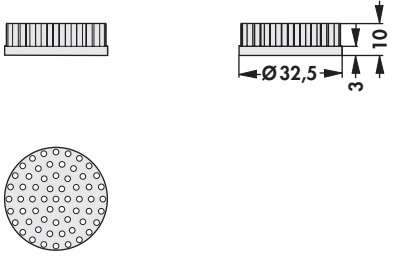
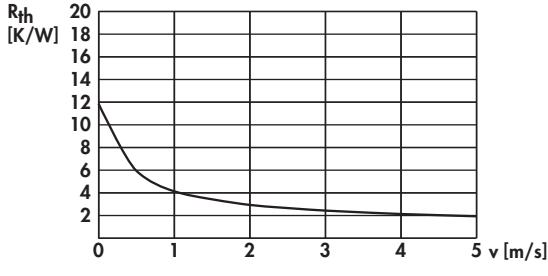
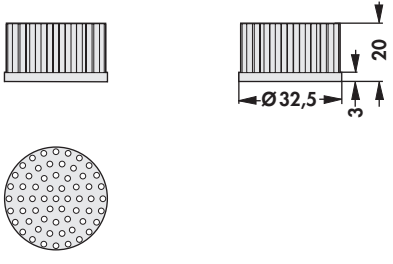
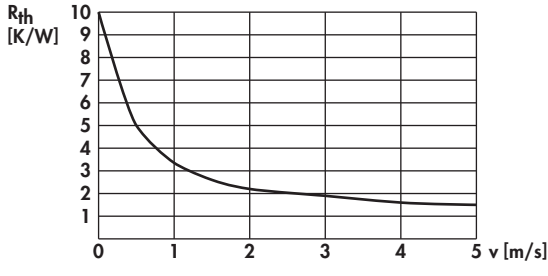
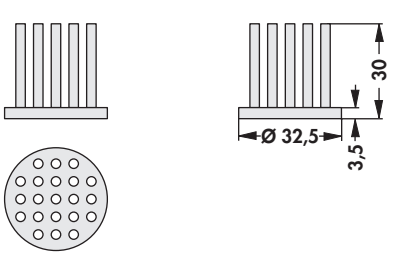
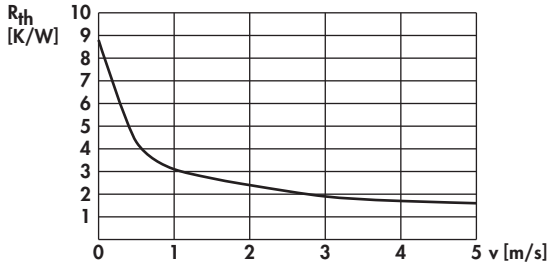
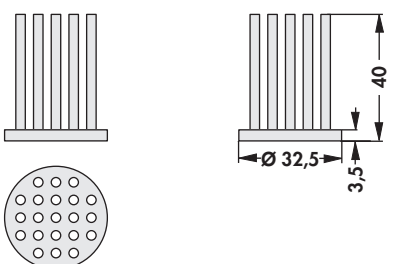
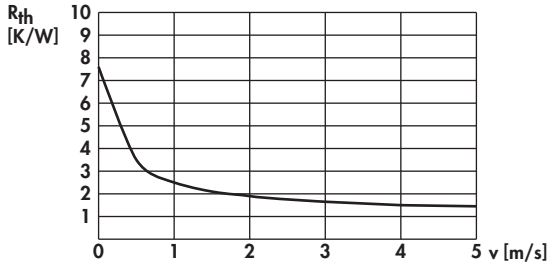
- arrangement and number of pins for optimum air flow
- suitable for forced and free convection
- excellent thermal conductivity by the alloy material (EN AW 1050 A; 220 W/mK) and homogeneous arrangement of materials
- constant heat dissipation in the base and the pins in the direction of heat flow
- low weight achieved by optimised geometry
- components fastened using glue, adhesive foil or clamps
- customer-specific modifications and special designs
- other pin-lengths and surfaces on request

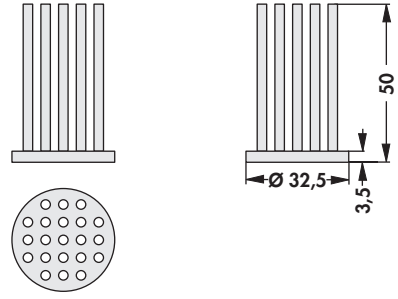
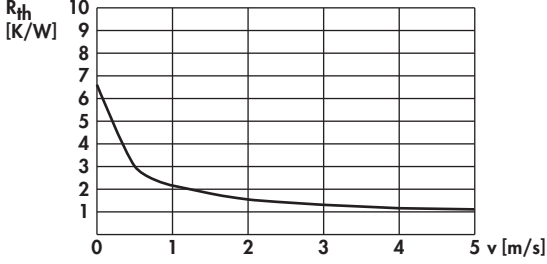
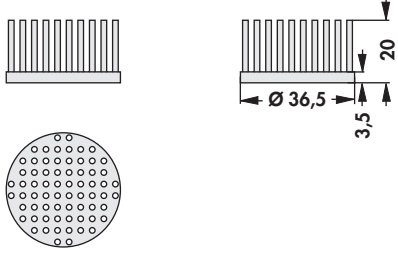
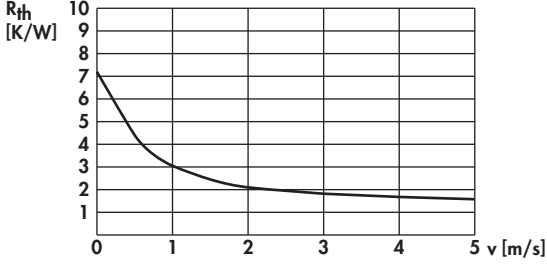
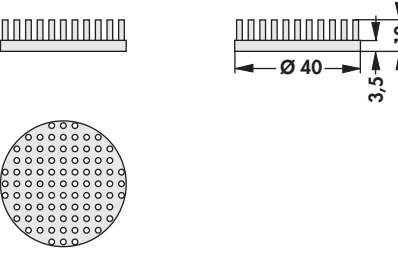

<p>art. no.</p> <p>ICK S R 28,5 x 6,5 WLF ... D 28,5 weight: 4.41g</p>		
<p>art. no.</p> <p>ICK S R 28,5 x 10 WLF ... D 28,5 weight: 5.16g</p>		
<p>art. no.</p> <p>ICK S R 28,5 x 12,5 WLF ... D 28,5 weight: 5.7g</p>		
<p>surface:</p>		<p>Al-natural</p>

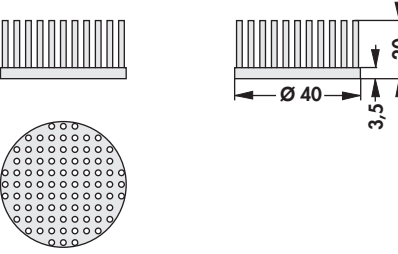
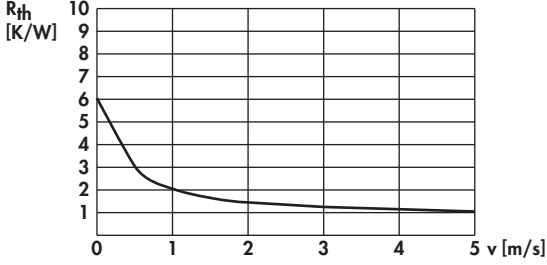
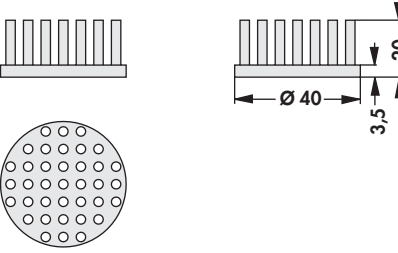
<p>art. no.</p> <p>ICK S R 28,5 x 18,5 WLF ... D 28,5 weight: 6.98g</p>		
<p>art. no.</p> <p>ICK S R 32,5 x 10 WLF ... D 32 weight: 9.7g</p>		
<p>art. no.</p> <p>ICK S R 32,5 x 20 WLF ... D 32 weight: 13.8g</p>		
<p>art. no.</p> <p>ICK S R 32,5 x 30 WLF ... D 32 weight: 20.6g</p>		
<p>art. no.</p> <p>ICK S R 32,5 x 40 WLF ... D 32 weight: 24.61g</p>		
<p>surface:</p>		<p>Al-natural</p>

Pin heatsinks round

<p>art. no.</p> <p>ICK S R 32,5 x 50 WLF ... D 32 weight: 28.62g</p>		
<p>art. no.</p> <p>ICK S R 36,5 x 20 WLF ... D 36,5 weight: 17.59g</p>		
<p>art. no.</p> <p>ICK S R 40 x 10 WLF ... D 40 weight: 15.85g</p>		
<p>art. no.</p> <p>ICK S R 40 x 20 WLF ... D 40 weight: 21.96g</p>		
<p>art. no.</p> <p>ICK S R A 40 x 20 WLF ... D 40 weight: 22.18g</p>		
<p>surface:</p>		<p>Al-natural</p>

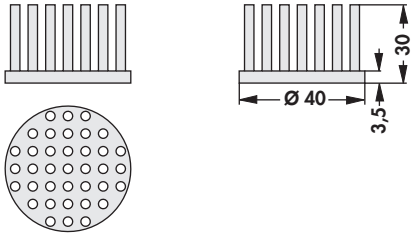
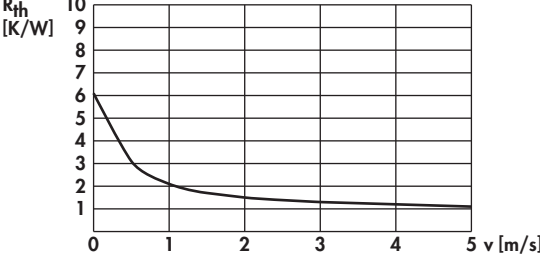
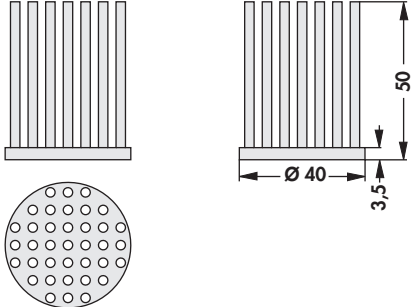
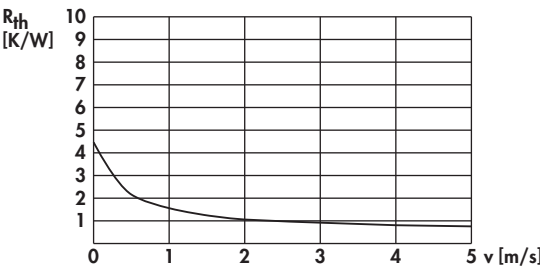
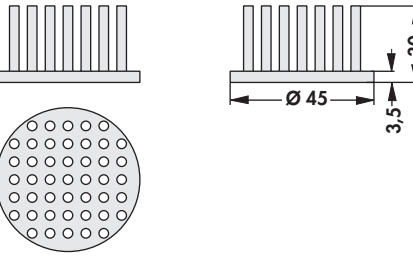
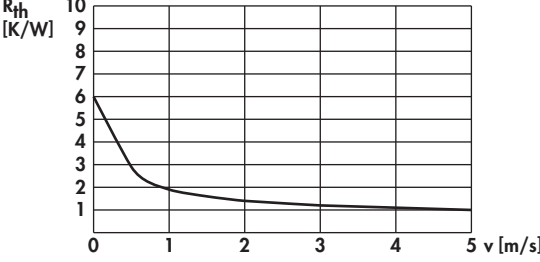
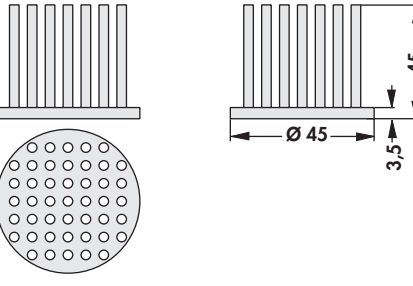
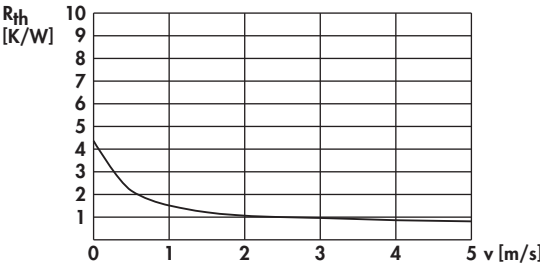
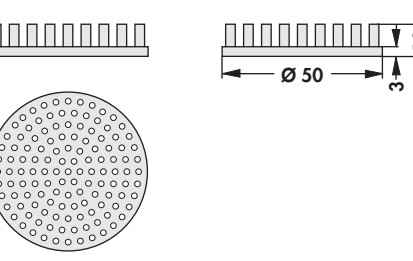
Pin heatsinks round

<p>art. no.</p> <p>ICK S R 40 x 30 WLF ... D 40 weight: 29.24g</p>		
<p>art. no.</p> <p>ICK S R 40 x 50 WLF ... D 40 weight: 48g</p>		
<p>art. no.</p> <p>ICK S R 45 x 30 WLF ... D 45 weight: 37.78g</p>		
<p>art. no.</p> <p>ICK S R 45 x 45 WLF ... D 45 weight: 50.67g</p>		
<p>art. no.</p> <p>ICK S R 50 x 10 WLF ... D 50 weight: 22g</p>		
<p>surface:</p>		<p>Al-natural</p>

Pin heatsinks round

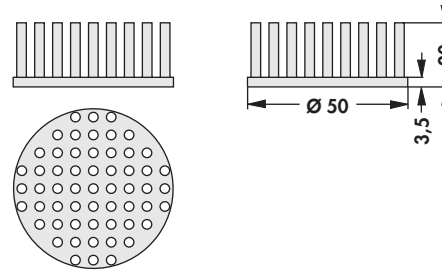
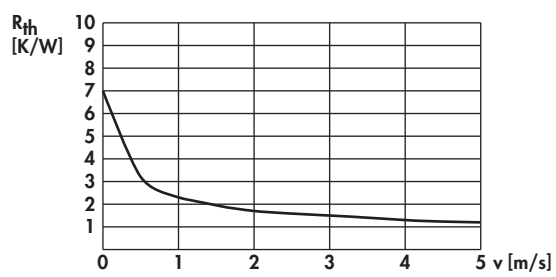
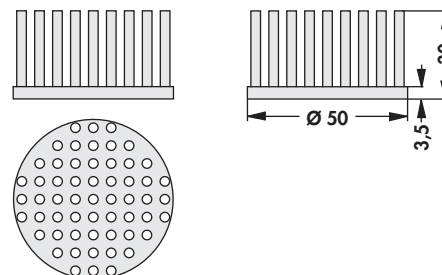
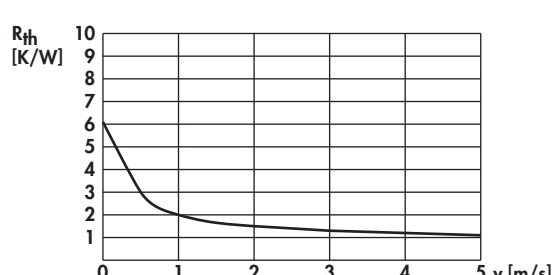
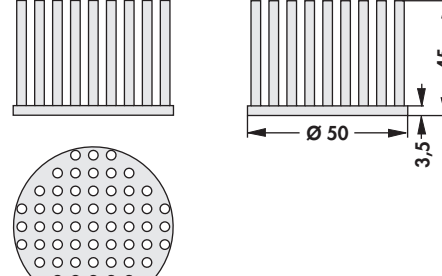
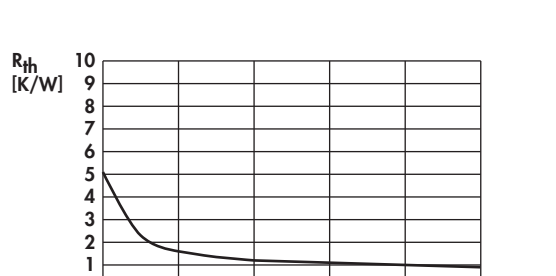
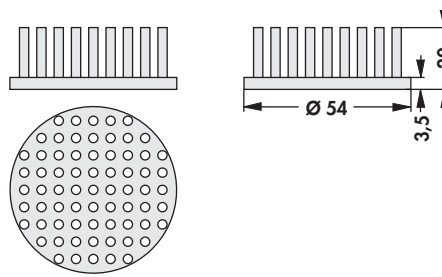
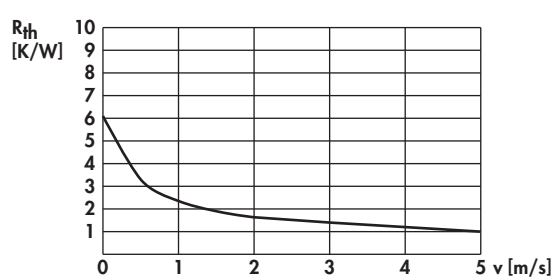
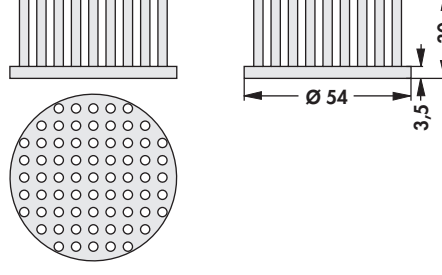
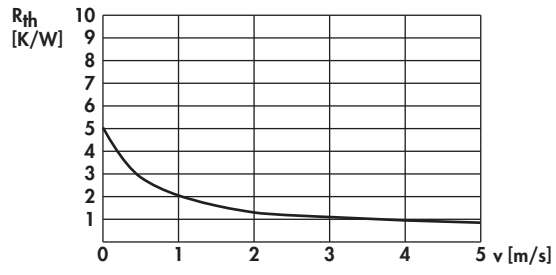
<p>art. no.</p> <p>ICK S R 50 x 20 WLF ... D 50 weight: 34.39g</p>		
<p>art. no.</p> <p>ICK S R 50 x 30 WLF ... D 50 weight: 45.28g</p>		
<p>art. no.</p> <p>ICK S R 50 x 45 WLF ... D 50 weight: 61.59g</p>		
<p>art. no.</p> <p>ICK S R 54 x 20 WLF ... D 54 weight: 40.94g</p>		
<p>art. no.</p> <p>ICK S R 54 x 30 WLF ... D 54 weight: 54.11g</p>		
<p>surface:</p>		<p>Al-natural</p>

Pin heatsinks round

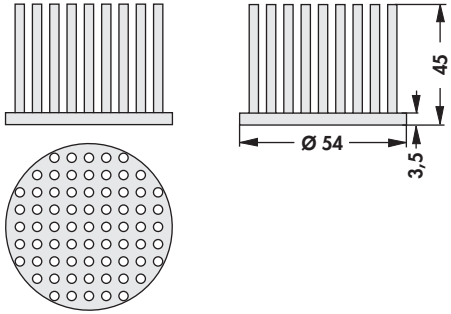
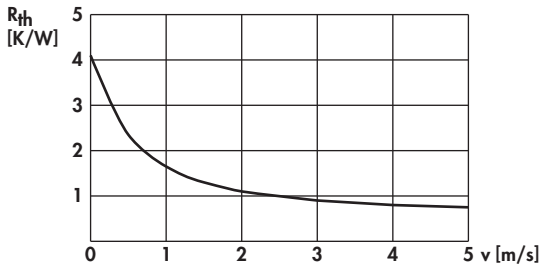
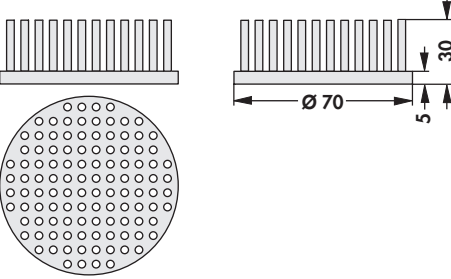
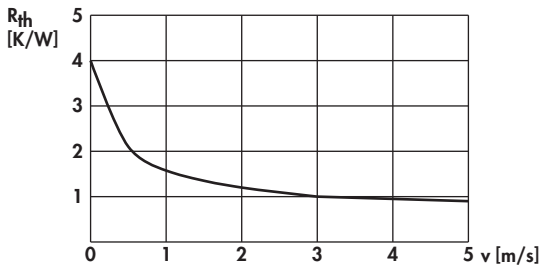
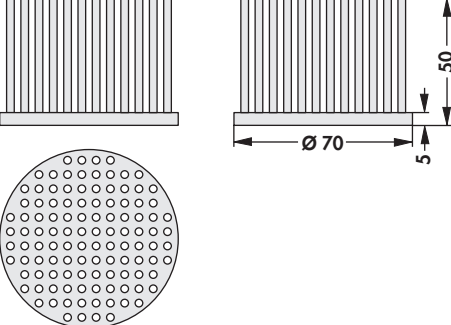
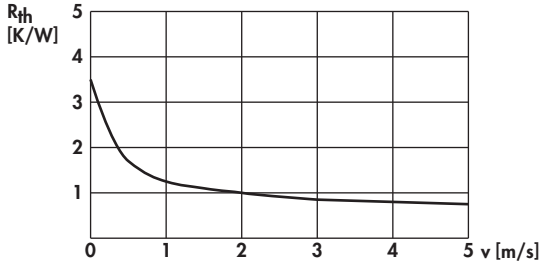
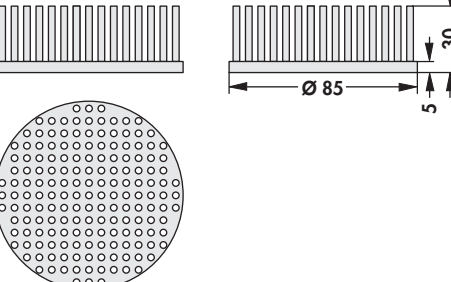
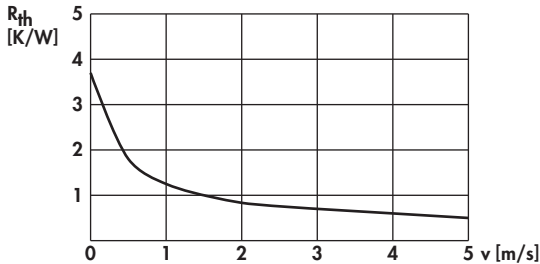
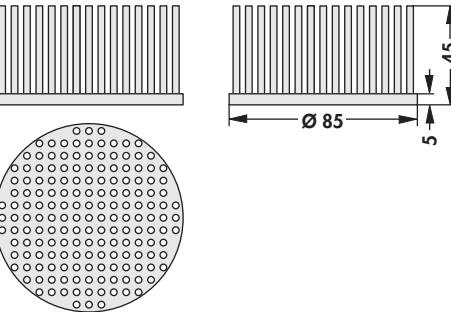
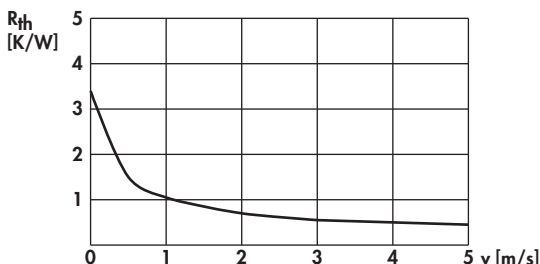
<p>art. no.</p> <p>ICK S R 54 x 45 WLF ... D 54 weight: 73.86g</p>		
<p>art. no.</p> <p>ICK S R 70 x 30 WLF ... D 70 weight: 92.8g</p>		
<p>art. no.</p> <p>ICK S R 70 x 50 WLF ... D 70 weight: 135.56g</p>		
<p>art. no.</p> <p>ICK S R 85 x 30 WLF ... D 85 weight: 157g</p>		
<p>art. no.</p> <p>ICK S R 85 x 45 WLF ... D 85 weight: 164g</p>		
<p>surface:</p>		<p>Al-natural</p>

Pin heatsinks round

art. no.

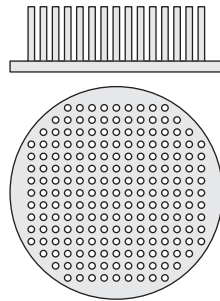
**ICK S R 98 x 30**

WLF ... D 98

weight: 117.5g

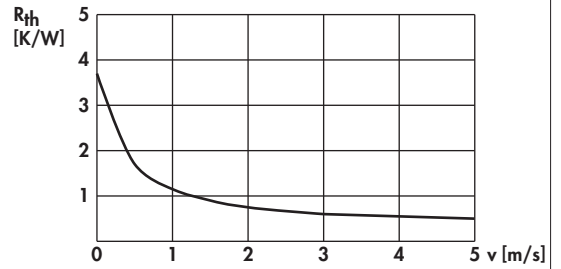

art. no.

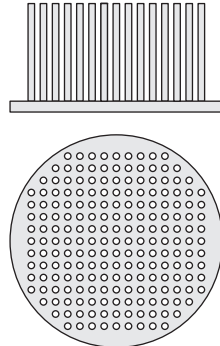
**ICK S R 98 x 50**

WLF ... D 98

weight: 194.23g

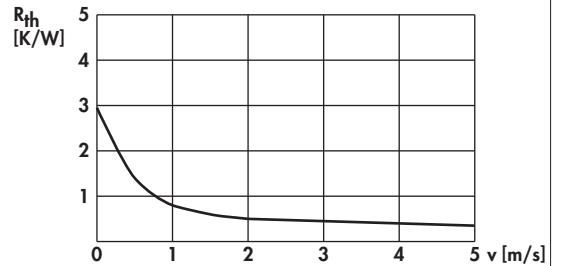

surface:

Al-natural

art. no.

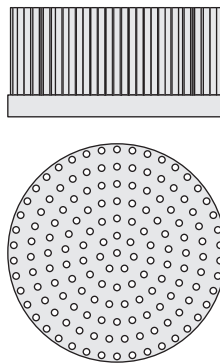
**ICK S R 100 x 50**

WLF ... D 100

weight: 320g

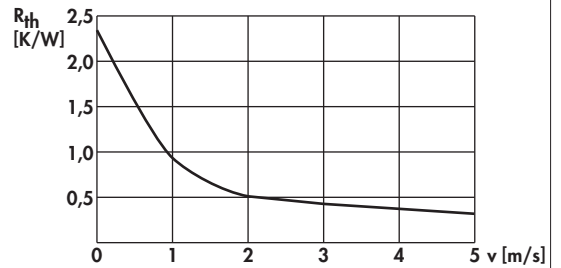

art. no.

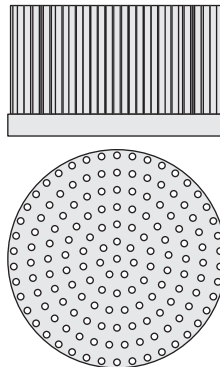
**ICK S R 100 x 70**

WLF ... D 100

weight: 381.5g

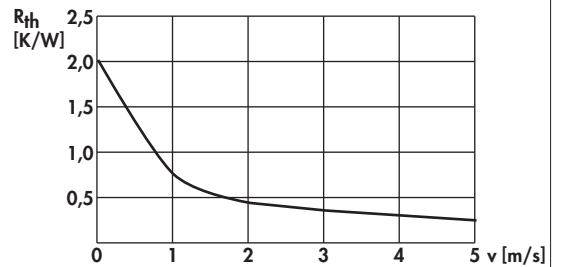

surface:

black anodised

Pin heatsinks round

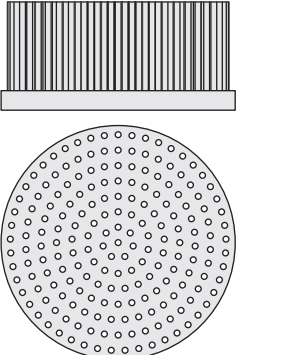
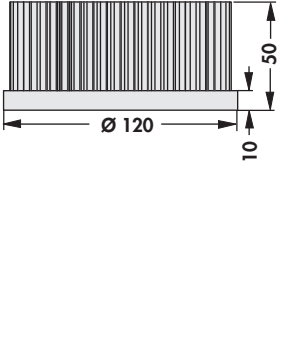
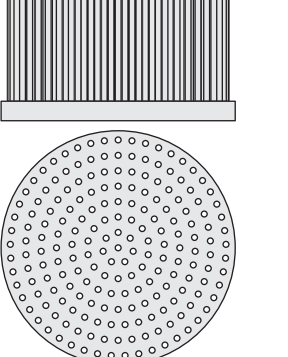
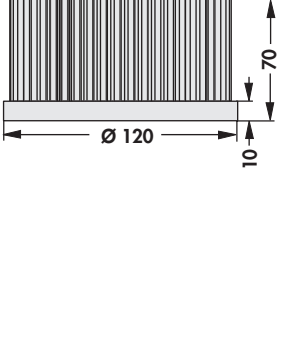
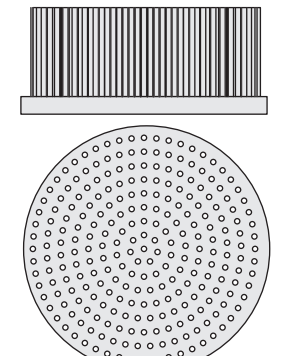
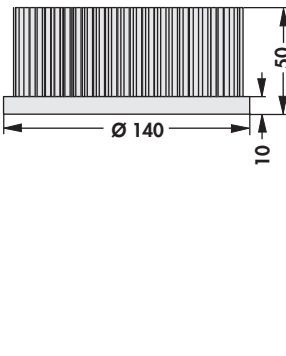
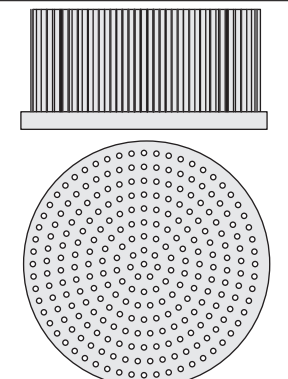
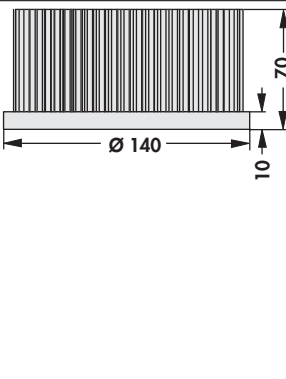
<p>art. no.</p> <p>ICK S R 120 x 50 WLF ... D 120 weight: 455.8g</p>		
<p>art. no.</p> <p>ICK S R 120 x 70 WLF ... D 120 weight: 530.9g</p>		
<p>art. no.</p> <p>ICK S R 140 x 50 WLF ... D 140 weight: 608.8g</p>		
<p>art. no.</p> <p>ICK S R 140 x 70 WLF ... D 140 weight: 705.3g</p>		
<p>surface:</p>		<p>black anodised</p>

Pin heatsinks round

art. no.

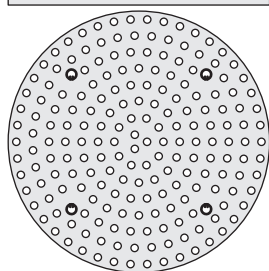
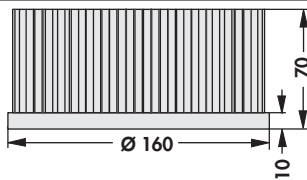
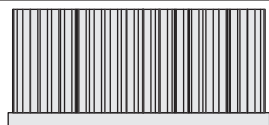
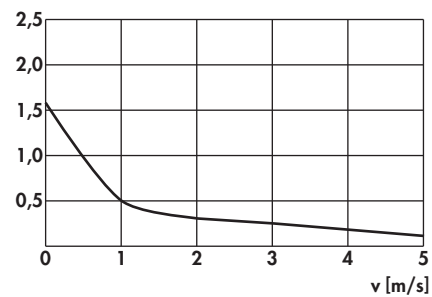
 R_{th}
[K/W]**ICK S R 160 x 70**

WLF ... D 160

weight: 1,055g

Mounting possibility for fans 92 x 92 mm





surface:

black anodised

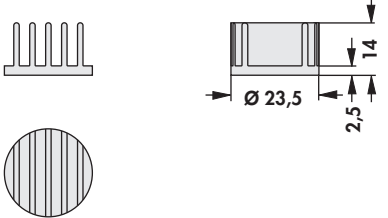
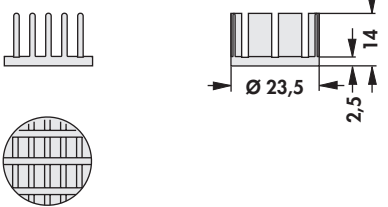
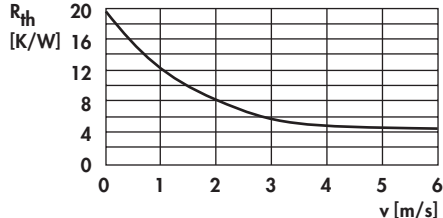
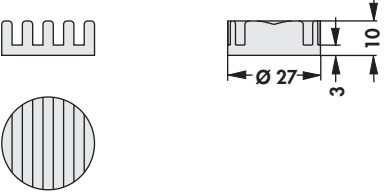
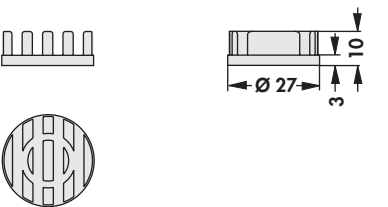
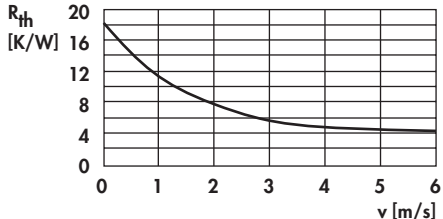
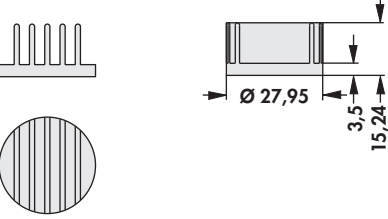

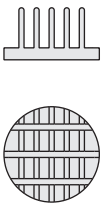
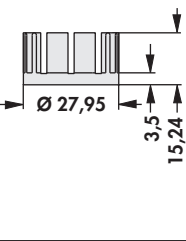
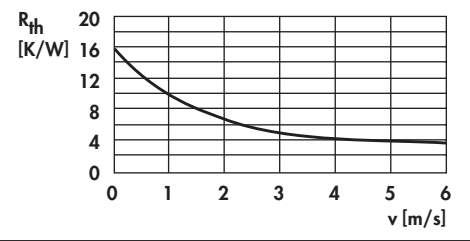
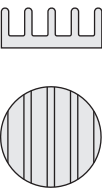
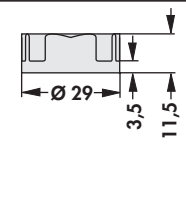
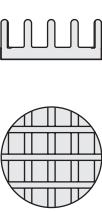
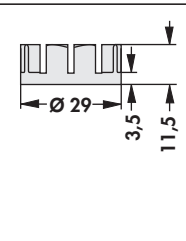
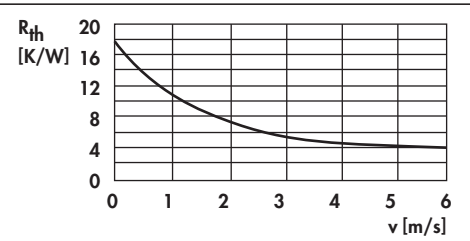
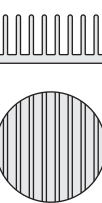
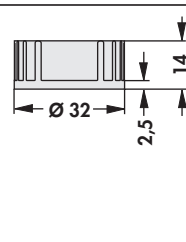
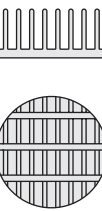
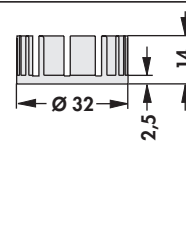
- suitable for free or forced convection
- heat sink dimensions are fitted to the respective LED type
- simple mounting by using thermally conductive adhesive foil, glue or screw mounting
- specific versions on customer's request
- double-sided adhesive thermal conductive foil **WLF ...** → E 39
- special design, surfaces and modification to customer specification on request

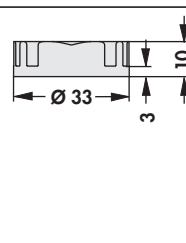
<p>art. no.</p> <p>ICK LED R 23,5 x 14 WLF ... D 23</p>		<p>$R_{th} = 18,58 \text{ K/W}$</p>
<p>art. no.</p> <p>ICK LED R 23,5 x 14 G WLF ... D 23</p>		
<p>art. no.</p> <p>ICK LED R 27 x 10 WLF ... D 27</p>		<p>$R_{th} = 17,69 \text{ K/W}$</p>
<p>art. no.</p> <p>ICK LED R 27 x 10 G WLF ... D 27</p>		
<p>art. no.</p> <p>ICK LED R 28 x 15 WLF ... D 28</p>		<p>$R_{th} = 15,24 \text{ K/W}$</p>
<p>surface:</p>		<p>black anodised</p>

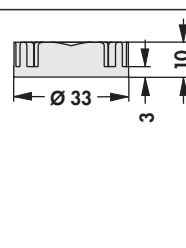
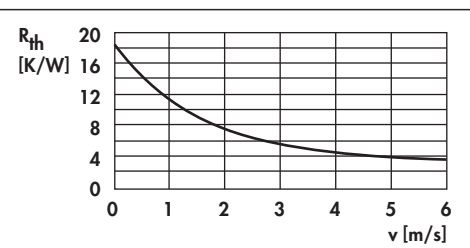
art. no. ICK LED R 28 x 15 G WLF ... D 28			
art. no. ICK LED R 29 x 11,5 WLF ... D 29			$R_{th} = 17,26 \text{ K/W}$
art. no. ICK LED R 29 x 11,5 G WLF ... D 29			
art. no. ICK LED R 32 x 14 WLF ... D 32			$R_{th} = 15,23 \text{ K/W}$
art. no. ICK LED R 32 x 14 G WLF ... D 32			
art. no. ICK LED R 33 x 10 WLF ... D 33			$R_{th} = 17,6 \text{ K/W}$
art. no. ICK LED R 33 x 10 G WLF ... D 33			
surface:		black anodised	

<p>art. no.</p> <p>ICK LED R 33 x 16,5 WLF ... D 33</p>		<p>$R_{th} = 13,87 \text{ K/W}$</p>
<p>art. no.</p> <p>ICK LED R 33 x 16,5 G WLF ... D 33</p>		
<p>art. no.</p> <p>ICK LED R 35 x 10 WLF ... D 35</p>		<p>$R_{th} = 16,9 \text{ K/W}$</p>
<p>art. no.</p> <p>ICK LED R 35 x 10 G WLF ... D 35</p>		
<p>art. no.</p> <p>ICK LED R 36 x 12 WLF ... D 36</p>		<p>$R_{th} = 12,88 \text{ K/W}$</p>
<p>art. no.</p> <p>ICK LED R 36 x 12 G WLF ... D 36</p>		
<p>art. no.</p> <p>ICK LED R 40 x 10 WLF ... D 40</p>		<p>$R_{th} = 12,28 \text{ K/W}$</p>
<p>surface:</p>		<p>black anodised</p>

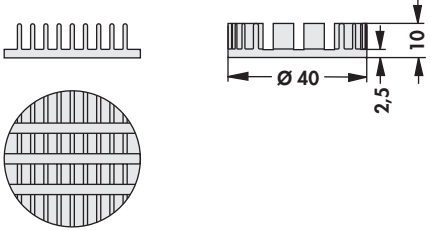
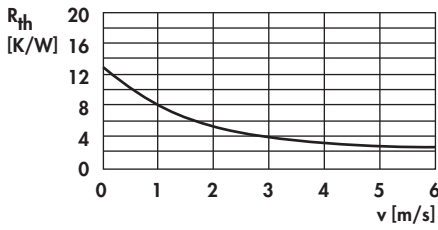
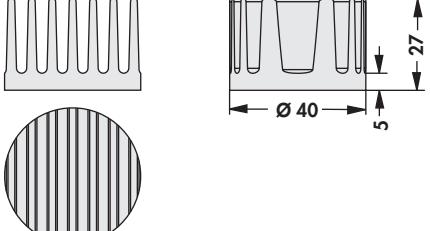
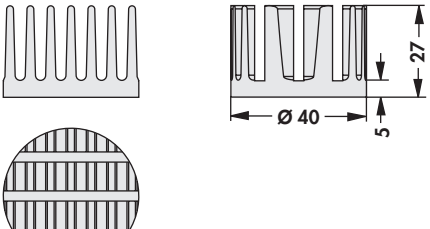
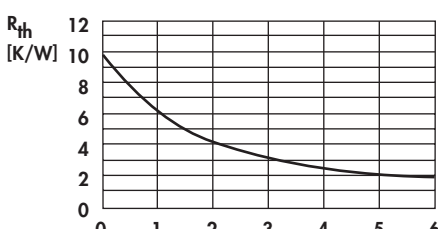
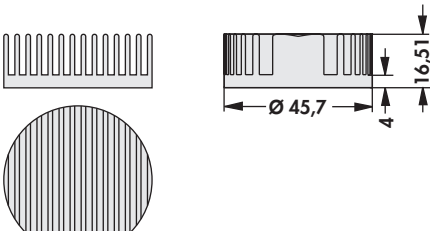
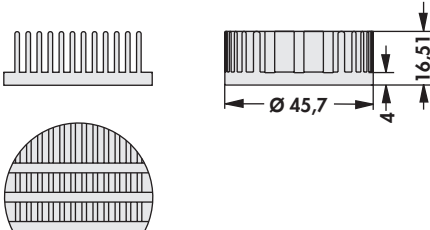
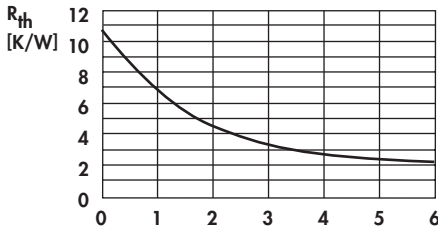
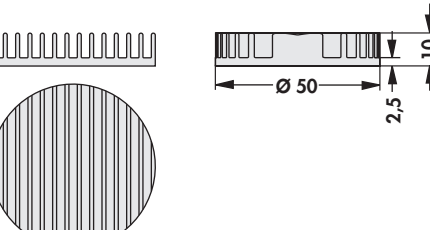

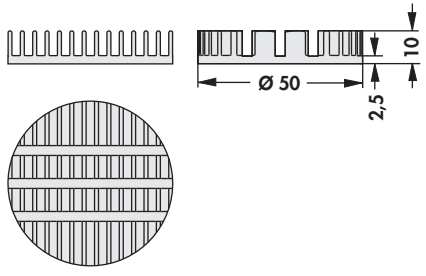
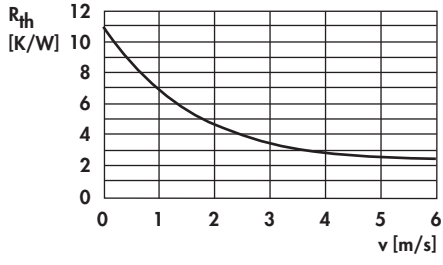
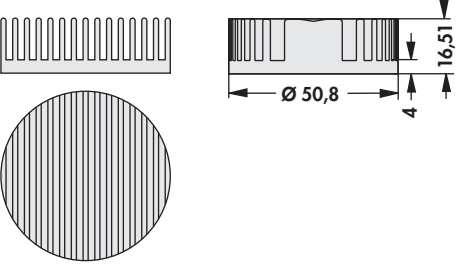
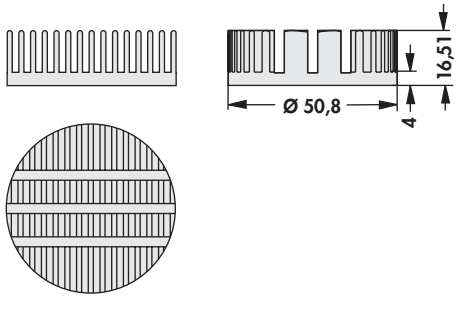
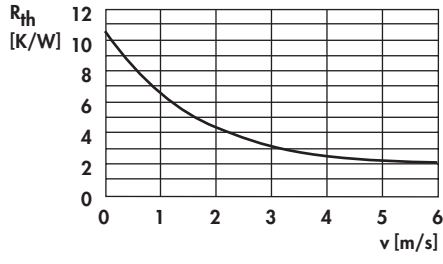
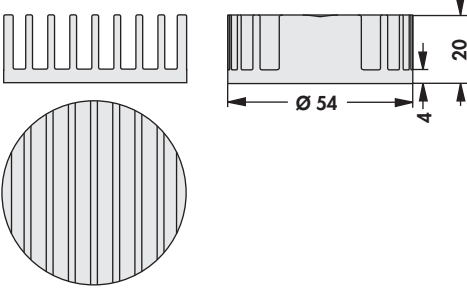
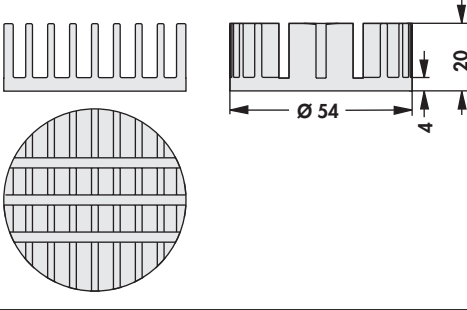
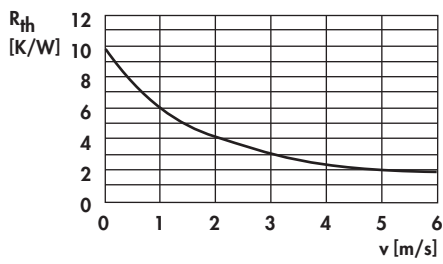

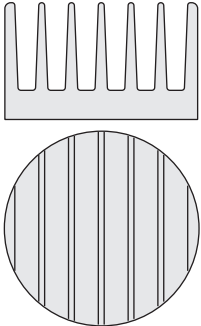
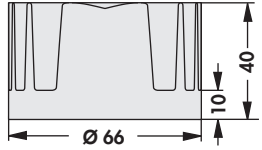
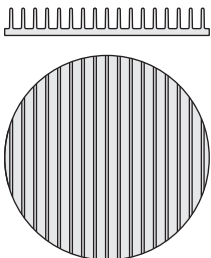
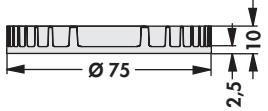
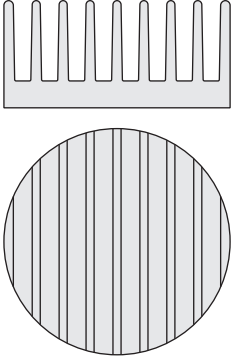
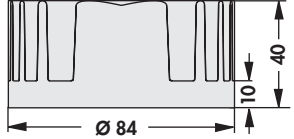
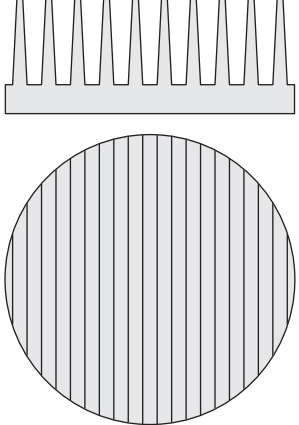
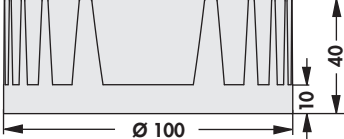
art. no. ICK LED R 40 x 10 G WLF ... D 40		
art. no. ICK LED R 40 x 27 WLF ... D 40		$R_{th} = 9,41 \text{ K/W}$
art. no. ICK LED R 40 x 27 G WLF ... D 40		
art. no. ICK LED R 45,7 x 16,5 WLF ... D 45		$R_{th} = 10,46 \text{ K/W}$
art. no. ICK LED R 45,7 x 16,5 G WLF ... D 45		
art. no. ICK LED R 50 x 10 WLF ... D 50		$R_{th} = 10,57 \text{ K/W}$
surface:	black anodised	

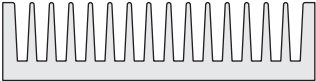
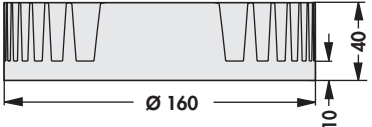
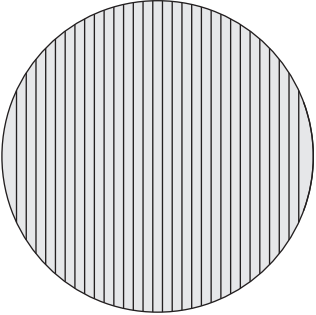
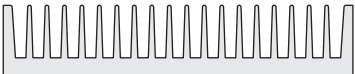
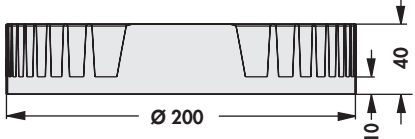
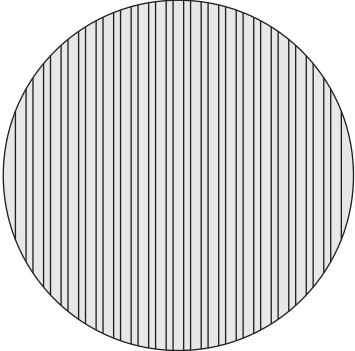



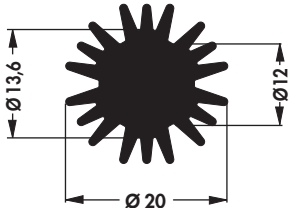
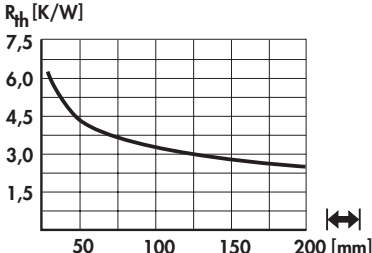
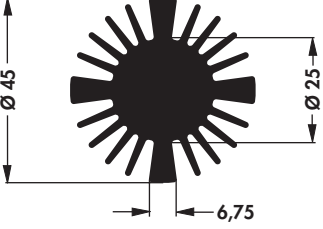
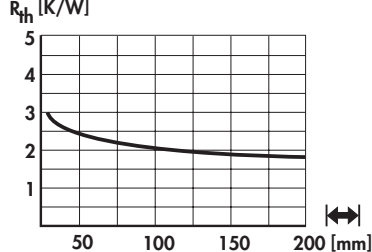

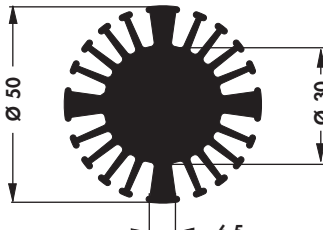
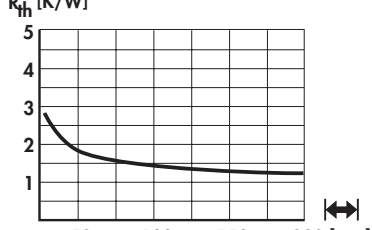
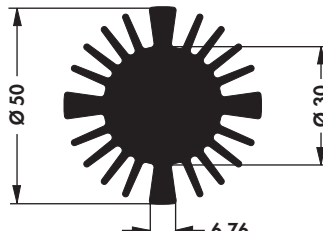
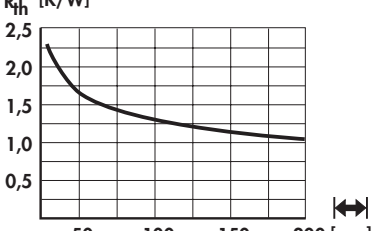
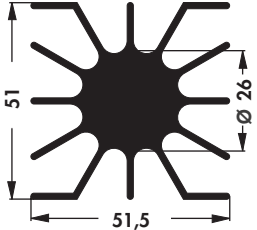
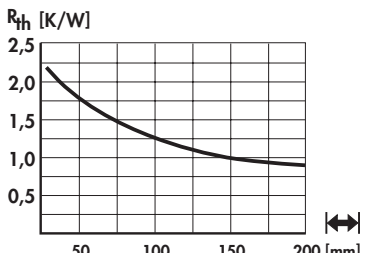
<p>art. no.</p> <p>ICK LED R 50 x 10 G WLF ... D 50</p>		
<p>art. no.</p> <p>ICK LED R 50,8 x 16,5 WLF ... D 50</p>		<p>$R_{th} = 10,17 \text{ K/W}$</p>
<p>art. no.</p> <p>ICK LED R 50,8 x 16,5 G WLF ... D 50</p>		
<p>art. no.</p> <p>ICK LED R 54 x 20 WLF ... D 54</p>		<p>$R_{th} = 9,48 \text{ K/W}$</p>
<p>art. no.</p> <p>ICK LED R 54 x 20 G WLF ... D 54</p>		
<p>surface:</p>		<p>black anodised</p>

art. no. ICK LED R 66 x 40 WLF ... D 66		 <p>$R_{th} = 3,2 \text{ K/W}$</p>
art. no. ICK LED R 75 x 10 WLF ... D 75		 <p>$R_{th} = 5,2 \text{ K/W}$</p>
art. no. ICK LED R 84 x 40 WLF ... D 84		 <p>$R_{th} = 2,5 \text{ K/W}$</p>
art. no. ICK LED R 100 x 40 WLF ... D 100		 <p>$R_{th} = 2 \text{ K/W}$</p>
surface:	black anodised	

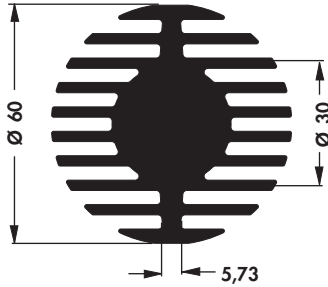
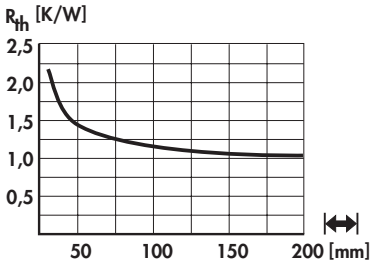
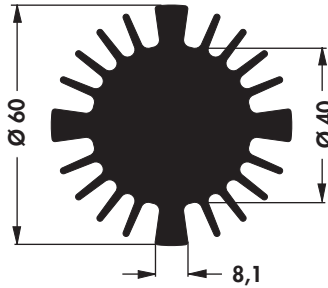
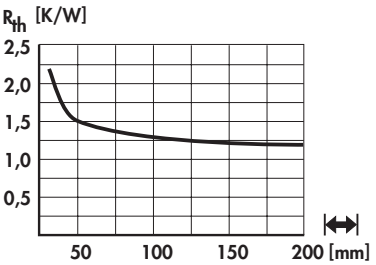
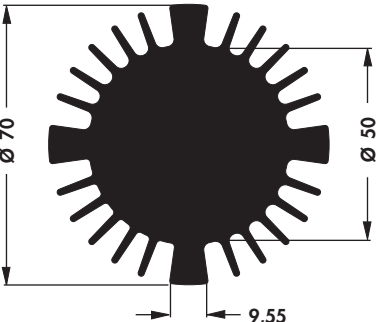
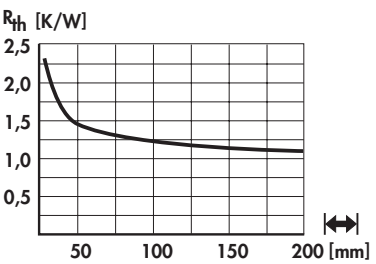
<p>art. no.</p>			<p>B</p>	
<p>ICK LED R 160 x 40 WLF ... D 160</p>		<p>$R_{th} = 1,4 \text{ K/W}$</p>	<p>C</p>	
<p>art. no.</p>			<p>D</p>	
<p>ICK LED R 200 x 40 WLF ... D 200</p>		<p>$R_{th} = 1 \text{ K/W}$</p>	<p>E</p>	
<p>surface:</p>	<p>black anodised</p>			<p>F</p>
<p>art. no.</p>	<p> </p>	<p>G</p>		
<p> </p>	<p> </p>	<p>H</p>		
<p> </p>	<p> </p>	<p>I</p>		
<p> </p>	<p> </p>	<p>K</p>		
<p> </p>	<p> </p>	<p>L</p>		
<p> </p>	<p> </p>	<p>M</p>		

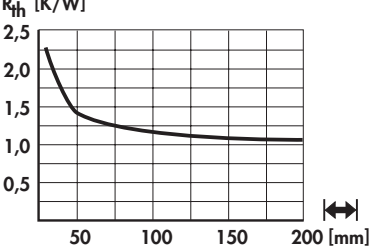
- up from a profile length of 25 mm: optional adapter plate **AD LED 53** → B 55 suitable for LED modules: Bridgelux Vero, Citizen CitiLED, Cree XLamp, Edison Edilex, GE Infusion, Lustrous Lustron, Megaman Teco, Osram PrevaLED and Soleriq, Philips Fortimo and Luxeon, Prolight Opto, Sharp Mega Zenigata, Toshiba E-Core, Tridonic Stark, Vexica Lumaera, Vossloh Schwabe Luga Shop and Industrial
- special design, surfaces and modification to customer specification on request

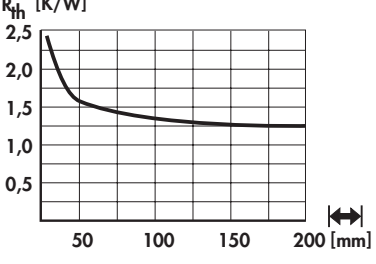
art. no. SK 585 ...		
art. no. SK 618 ...		
please indicate: ...  10 15 20 25 37.5 50 1000 mm		
art. no. SK 602 ...		
art. no. SK 577 ...		
art. no. SK 46 ...		
please indicate: ...  10 15 20 25 37.5 50 1000 mm		
surface: black anodised		... adapter (optional) AD = adapter plate (art. no. AD LED 53)

<p>art. no.</p> <p>SK 578 ...</p>		
<p>art. no.</p> <p>SK 569 ...</p>		
<p>art. no.</p> <p>SK 570 ...</p>		
<p>art. no.</p> <p>SK 571 ...</p>		
<p>please indicate: ...  10 15 20 25 37.5 50 1000 mm</p> <p>... adapter (optional) AD = adapter plate (art. no. AD LED 53)</p>		
<p>art. no.</p> <p>SK 658 ...</p>		
<p>please indicate: ...  10 15 20 25 37.5 50 1000 mm</p>		
<p>surface: black anodised</p>		

art. no.		
SK 659 ...		

please indicate:

... **10 15 20 25 37.5 50 1000 mm**

art. no.		
SK 572 ...		

please indicate:

... **10 15 20 25 37.5 50 1000 mm**

... **adapter (optional)**

AD = adapter plate (art. no. AD LED 53)

surface:

black anodised



– adapter plate suitable for LED modules:



Bridgelux Vero, Citizen CitiLED, Cree XLamp, Edison Edilex, GE Infusion, Luga Shop und Industrial, Lustrous Lustron, Megaman Te-co, Osram PrevaLED und Soleriq, Philips Fortimo und Luxeon, Prolight Opto, Sharp Mega Zenigata, Toshiba E-Core, Tridonic Stark, Vexica Lumaera, Vossloh Schwabe

art. no.		
AD LED 53		

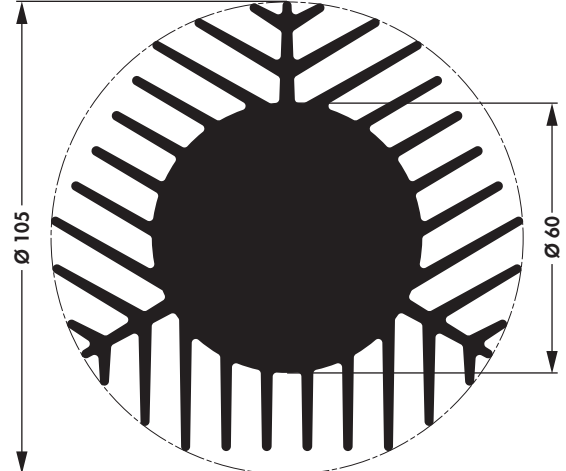
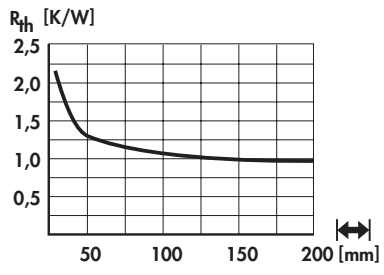
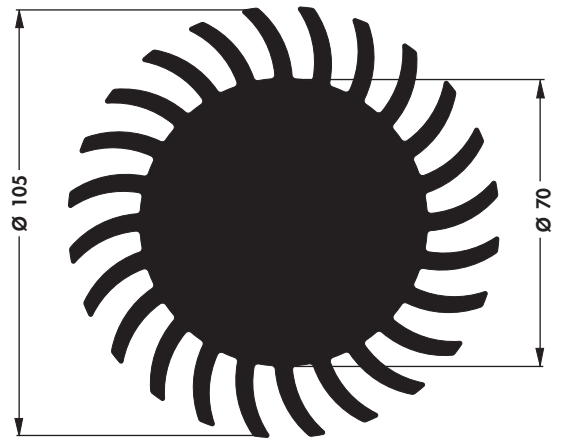
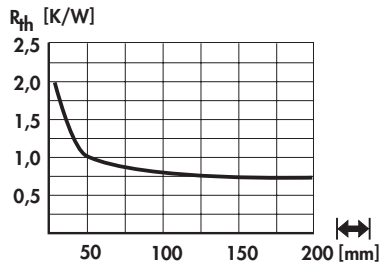
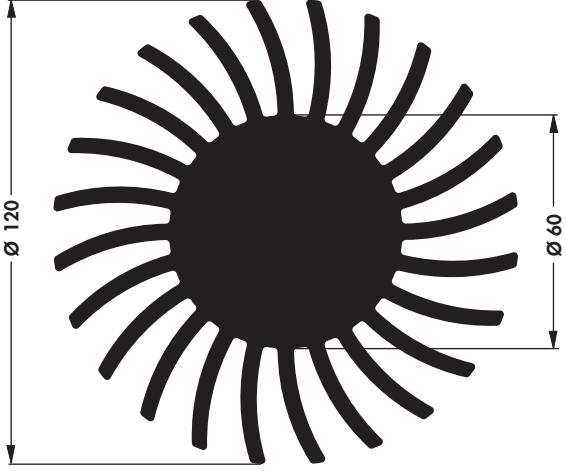
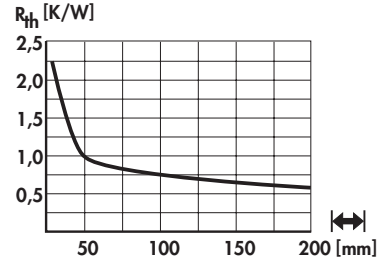
surface:

black anodised

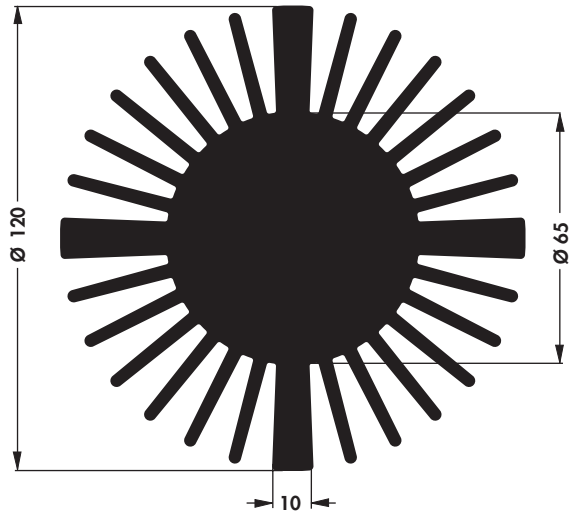
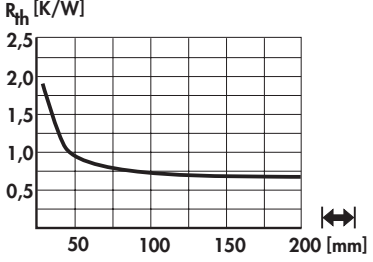
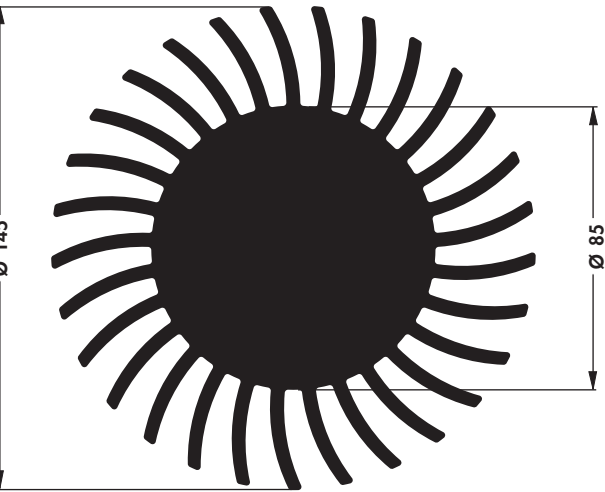
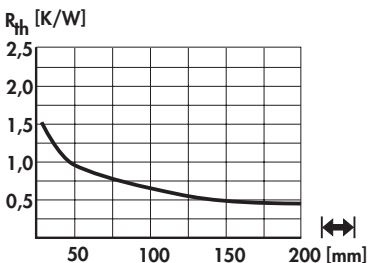
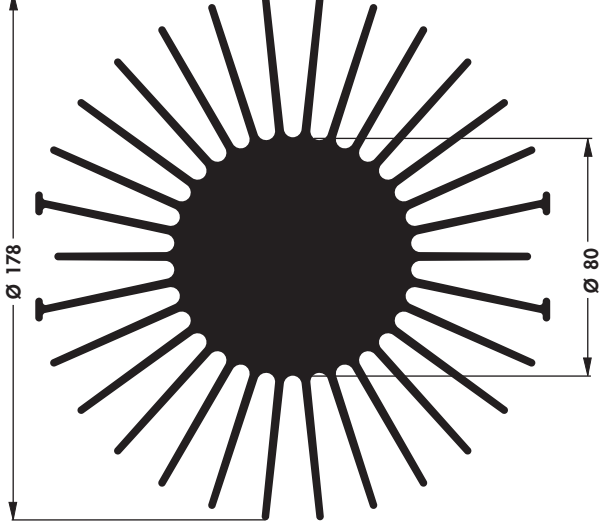
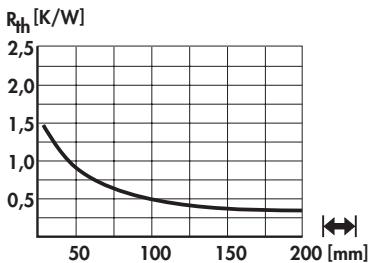
<p>art. no.</p> <p>SK 660 ...</p>		
<p>art. no.</p> <p>SK 584 ...</p>		
<p>art. no.</p> <p>SK 615 ...</p>		
<p>please indicate: ...  10 15 20 25 37.5 50 75 100 150 1000 mm</p>		
<p>surface:</p>		<p>black anodised</p>

<p>art. no.</p> <p>SK 599 ...</p>		
<p>art. no.</p> <p>SK 592 ...</p>		
<p>art. no.</p> <p>SK 590 ...</p>		
<p>please indicate: ...  10 15 20 25 37.5 50 75 100 150 1000 mm</p>		
<p>surface: black anodised</p>		

Heatsinks for LEDs

- suitable for LEDs:
Osram PrevaLED, Philips Lumileds and Luxeon, Prolight Opto, Sharp Mega Zenigata, Vossloh Schwabe Luga Shop and Industrial as well as all further Zhaga compliant LED modules with a mounting hole spacing of 35 mm
- special designs, surfaces and modifications to customer specification on request

art. no.		
SK 642 ...		
please indicate:	... 10 15 20 25 37.5 50 75 100 150 1000 mm	
surface:	black anodised	

- suitable for LEDs:
Bridgelux Vero, Citizen CitiLED, Cree XLamp, Edison Edilex, GE Infusion, Megaman Teco, Osram PrevaLED and Soleriq, Philips Fortimo, Lumileds and Luxeon, Prolight Opto, Sharp Mega Zenigata, Toshiba E-Core, Tridonic Stark, Vexica Lumaera, Vossloh Schwabe Luga Shop and Industrial, Zhaga
- fixing screws for LED modules and holder systems on request
- special designs, surfaces and modifications to customer specification on request

art. no.		
SK 643 ...		
please indicate:	... 10 15 20 25 37.5 50 75 100 150 1000 mm	
surface:	black anodised	

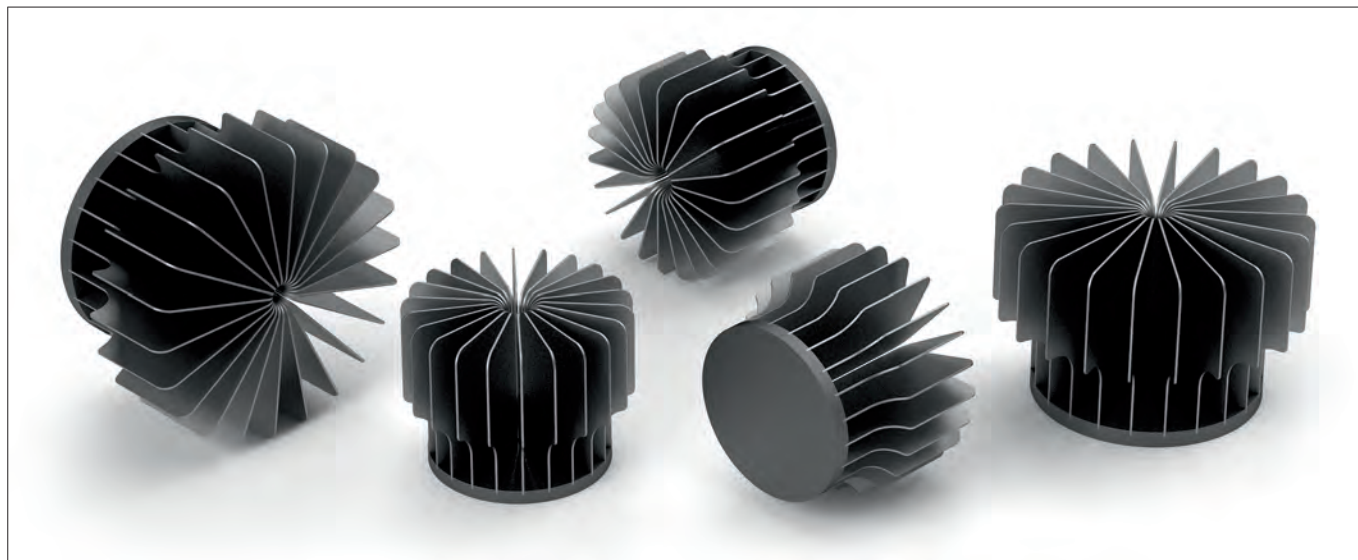

- particularly light and compact conception made of aluminium
- thermotechnically optimally fitted lamellas
- precise milled flat LED mounting surface
- adaptable to all common LED modules and sizes
- bottom plate for heat dissipation made of copper upon request
- customised designs and modifications acc. to drawing

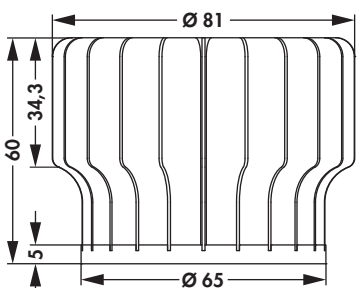
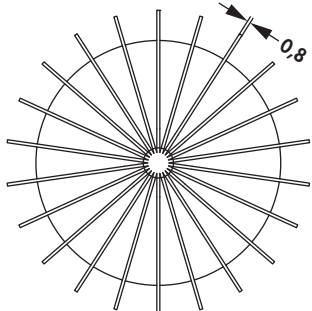
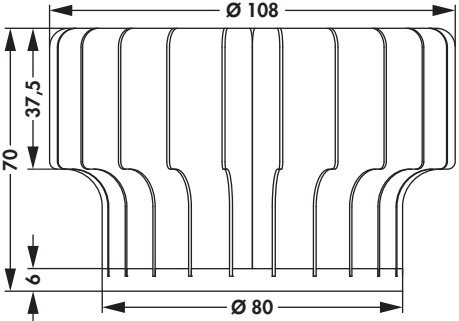
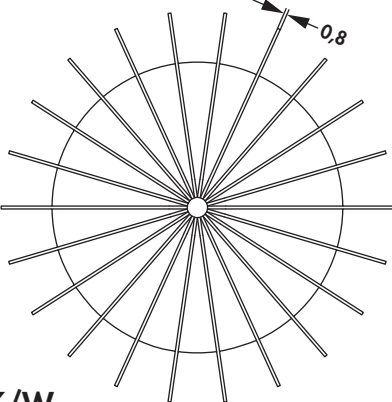
art. no. SK LED R 65 weight: 132g		 $R_{th} = 2,1 \text{ K/W}$
art. no. SK LED R 80 weight: 207g		 $R_{th} = 1,35 \text{ K/W}$
surface:	black anodised	
material:	aluminium bottom plate: EN AW 6060; sheet metal: EN AW 5754	
number of plates:	22	

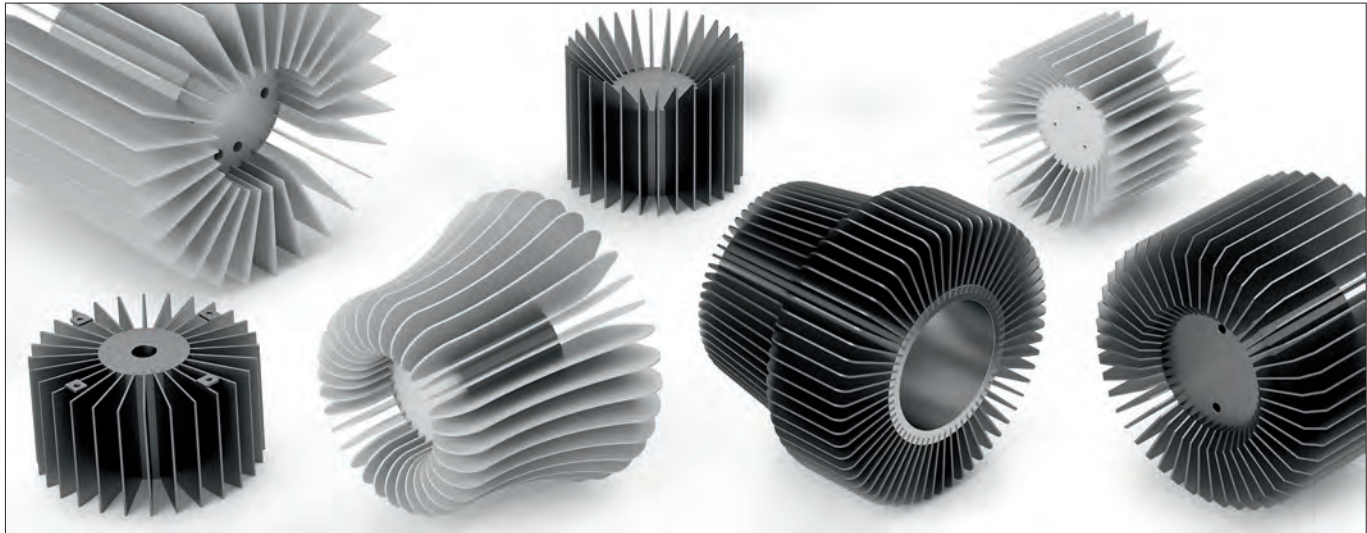

- individual LED heatsinks acc. to customer's requests
- adaptable to all common LED modules and sizes
- integration possibility of reflectors or fans by using special sheet metal design
- entry core for heat dissipation made of copper upon request
- other dimensions, sheet metal geometries, surfaces and mechanical machinings upon request

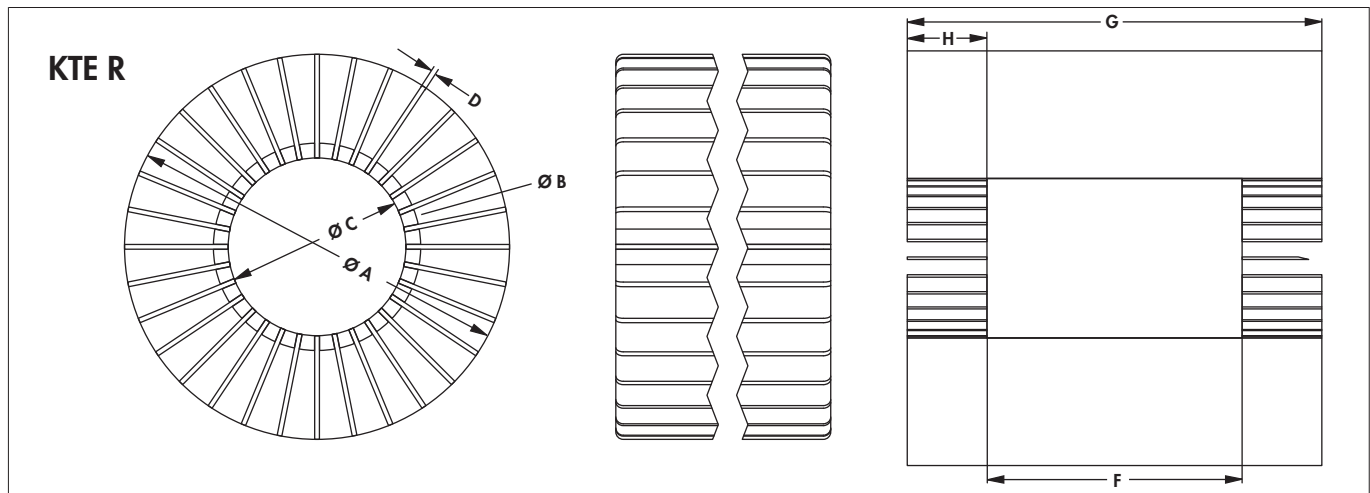

possible dimensions:

dim. [mm]								
A	B	C	D	E	F	G	H	
B + 20 to 200	35	30	0.8	32	max. 400	max. 800	max. 200	
	40	35	1	36				
	55	50	1.5	50				
	80	75	2	72				
	90	85		84				
	100	95		92				



E max. number of grooves at D = 0.8 mm

please indicate with your order:

dim. [mm]								
A	B	C	D	E	F	G	H	
please indicate: ... surface SA = black anodised ME = clear anodised								
material:			aluminium					



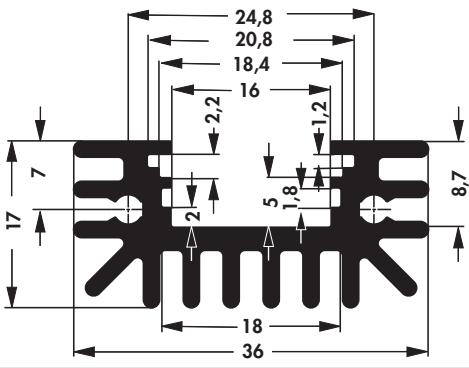
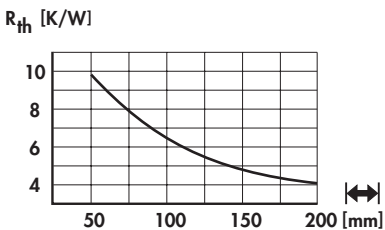
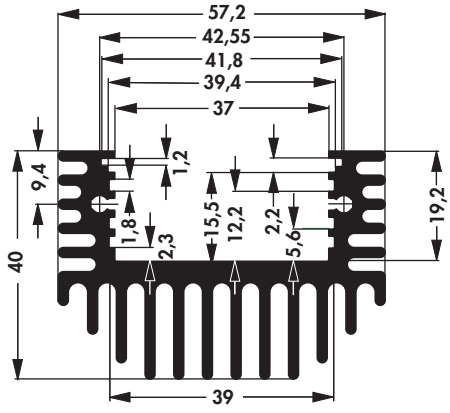
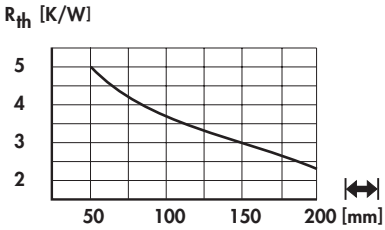

Heatsinks for LEDs

- suitable for flexible and rigid LED Line Modules
- possibility to insert covers made from metal sheets and plexiglass
- respective cases → **G LED ...** case catalogue **f.case**
- customer specific designs, lengths and treatments upon request

art. no. SK LED 1		
art. no. SK LED 3		
please indicate: ...  50 75 100 150 1000 mm		... surface SA = black anodised ME = natural colour anodised

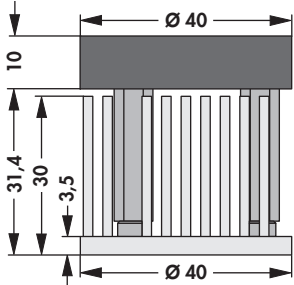
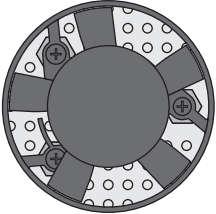
art. no.			
SK LED 4 ...			
please indicate:	... \longleftrightarrow 50 75 100 150 1000 mm	... surface SA = black anodised ME = natural colour anodised	... adapter (optional) AD = adapter plate (art. no. AD LED 53)

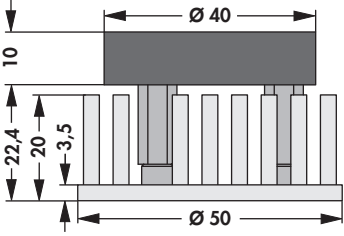
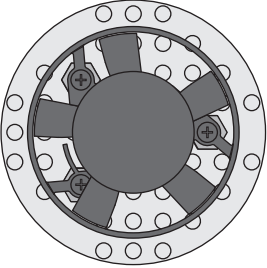
adapter plate → B 55

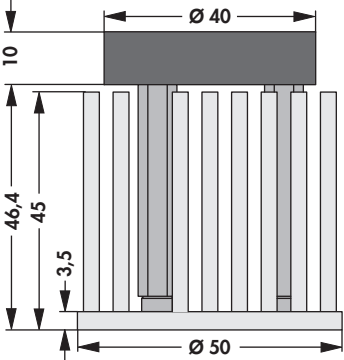
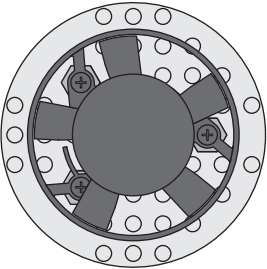
		
art. no.	R_{th} [K/W]	
LA LED 40 x 30	1.4	
		
art. no.	R_{th} [K/W]	
LA LED 50 x 20	1.25	
		
art. no.	R_{th} [K/W]	
LA LED 50 x 45	0.9	
surface:	Al-natural	

Technical data of the fans

	LF 40B12
circuit voltage	12 V
bearing type	two-way plain bearing
cur. consumpt.	50 mA
max. initial current	160 mA
max. volume flow	157 l/min - 9.4 m ³ /h
max. static pressure	3.4 mmH ₂ O - 33 Pa
noise level	26 dB(A), 1 m lateral
temperature range	-20°C... +60°C
failure rate (L₁₀)	60,000 h
MTBF	1,900,000 h (20°C)
type rotor speed	6,600 min ⁻¹
weight	10 g



- active heat dissipation of LED modules
- Zhaga compliant mounting possibility
- integrated low noise fan
- optional adapter plate **AD LED 53** → B 55 suitable for LED modules:
Bridgelux Vero, Citizen CitiLED, Cree XLamp, Edison Edilex, GE Infusion, Luga Shop und Industrial, Lustrous Lustron, Megaman Teco, Osram PrevaLED und Soleriq, Philips Fortimo und Luxeon, Prolight Opto, Sharp Mega Zenigata, Toshiba E-Core, Tridonic Stark, Vexica Lumaera, Vossloh Schwabe





art. no.			
LA LED 68 ...			
please indicate:	... \longleftrightarrow 50 75 100 mm	... surface SA = black anodised ME = natural colour anodised	... adapter (optional) AD = adapter plate (art. no. AD LED 53)

Technical data of the fans

	LF 40B12
circuit voltage	12 V
bearing type	two-way plain bearing
cur. consumpt.	50 mA
max. iinitial current	160 mA
max. volume flow	157 l/min - 9.4 m ³ /h
max. static pressure	3.4 mmH ₂ O - 33 Pa
noise level	26 dB(A), 1 m lateral
temperature range	-20°C... +60°C
failure rate (L₁₀)	60,000 h
MTBF	1,900,000 h (20°C)
type rotor speed	6,600 min ⁻¹
weight	10 g

Heatsinks for DIL-IC

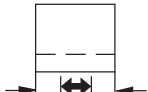
– other length on request

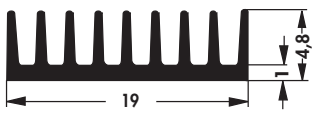
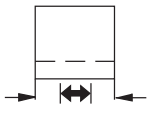

							
art. no.	for cases	↔ [mm]	R_{th} [K/W]	art. no.	for cases	↔ [mm]	R_{th} [K/W]
ICK 6 8 L	6/8 contacts	8.5	90	ICK 20 L	20 contacts	25.0	43
ICK 14 16 L	14/16 contacts	19.0	62				
							
art. no.	for cases	↔ [mm]	R_{th} [K/W]	art. no.	for cases	↔ [mm]	R_{th} [K/W]
ICK 14 16 B	14/16 contacts	6.3	54.0	ICK 36 B	36 contacts	47.0	24.3
ICK 24 B	24 contacts	33.0	25.8	ICK 40 B	40 contacts	51.0	24.0
ICK 28 B	28 contacts	37.0	25.6	ICK 1000 B	—	1000.0	—
surface:		black anodised					

– with clip

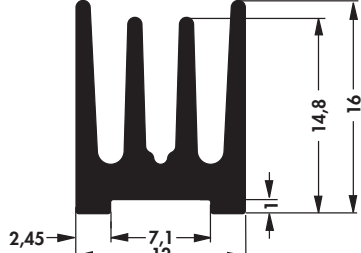
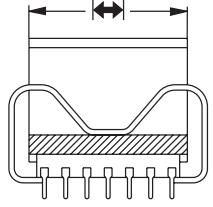
– other length on request

							
art. no.	for cases	↔ [mm]	R_{th} [K/W]	art. no.	for cases	↔ [mm]	R_{th} [K/W]
ICK 14 H	14 polig	18.0	20	ICK 18 H	18 contacts	23.0	16
ICK 16 H	16 contacts	20.5	18	ICK 1000 H	—	1000.0	—
surface:		black anodised					

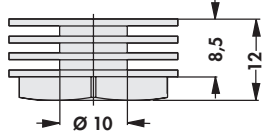
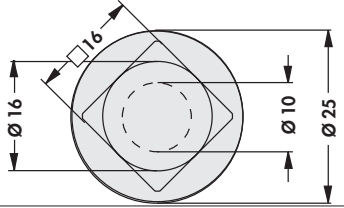
Heatsinks for PLCC

		
art. no.		R_{th} [K/W]
ICK R		19
		
art. no.	↔ [mm]	R_{th} [K/W]
ICK PLCC 28	11.8	25
surface:		black anodised



Heatsinks for SMD

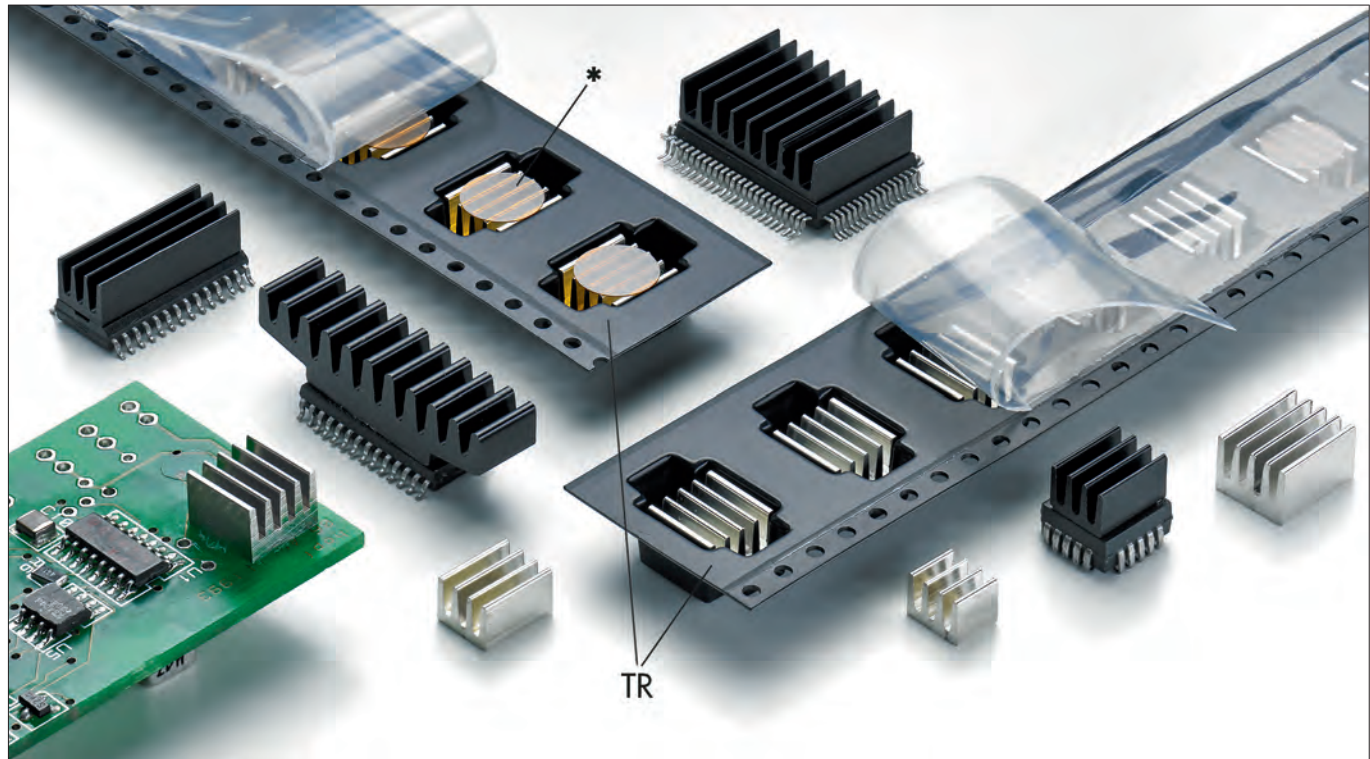

- especially suitable for SMD components
- low profile
- reduced weight
- effective heat dissipation
- can be glued directly onto the component
- solderable versions
- customer specific versions on request
- special packaging like tape and reel, bar magazin, tray etc. on request
- * = capton point
- TR = pick and place pad, tape and reel

art. no.	width [mm]	R_{th} [K/W]	art. no.	width [mm]	R_{th} [K/W]
ICK SMD A 5 ...	5	123	ICK SMD A 13 ...	13	63
ICK SMD A 8 ...	8	87	ICK SMD A 17 ...	17	51
ICK SMD A 10 ...	10	75	ICK SMD A 22 ...	22	34

art. no.	R_{th} [K/W]	diameter of tape [mm]	width of belt [mm]	quantity per reel
ICK SMD A 13 ... TR	63	330	24	1000

please indicate: ... surface
SA = black anodised
MI = solderable surface

B

C

D

E

F

G

H

I

K

L

M



Heatsinks for DIL-IC, PLCC and SMD

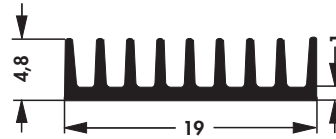

art. no.	width [mm]	R_{th} [K/W]	art. no.	width [mm]	R_{th} [K/W]
ICK SMD B 5 ...	5	56	ICK SMD B 13 SA	13	29
ICK SMD B 7 SA	7	47	ICK SMD B 19 ...	19	22
ICK SMD B 10 SA	10	35			

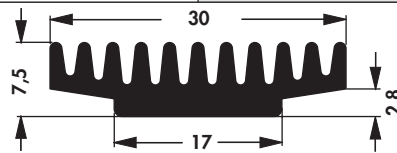

art. no.	width [mm]	R_{th} [K/W]	art. no.	width [mm]	R_{th} [K/W]
ICK SMD C 7 SA	7	33	ICK SMD C 17 ...	17	17
ICK SMD C 10 SA	10	26			

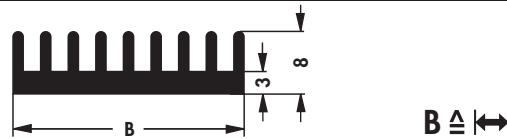

art. no.	width [mm]	R_{th} [K/W]	art. no.	width [mm]	R_{th} [K/W]
ICK SMD E 15 SA	15.3	27	ICK SMD E 29 SA	29.0	18
ICK SMD E 22 SA	22.3	21			

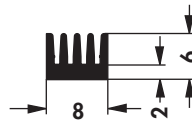

art. no.	width [mm]	R_{th} [K/W]	art. no.	width [mm]	R_{th} [K/W]
ICK SMD F 8 ...	8	74	ICK SMD F 19 ...	19	37
ICK SMD F 10 ...	10	71	ICK SMD F 21 ...	21	33
ICK SMD F 17 SA	17	42	ICK SMD F 26 ...	26	26

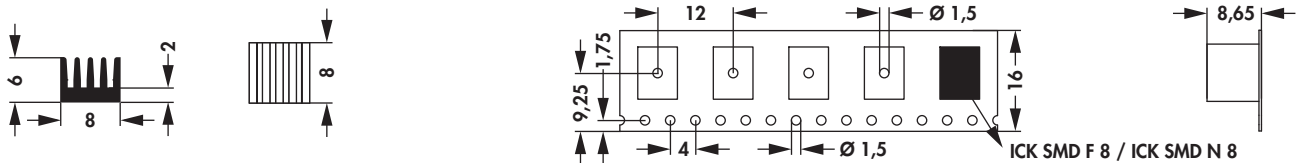

art. no.	R_{th} [K/W]	diameter of tape [mm]	width of belt [mm]	quantity per reel
ICK SMD F 8 ... TR	74	330	16	700

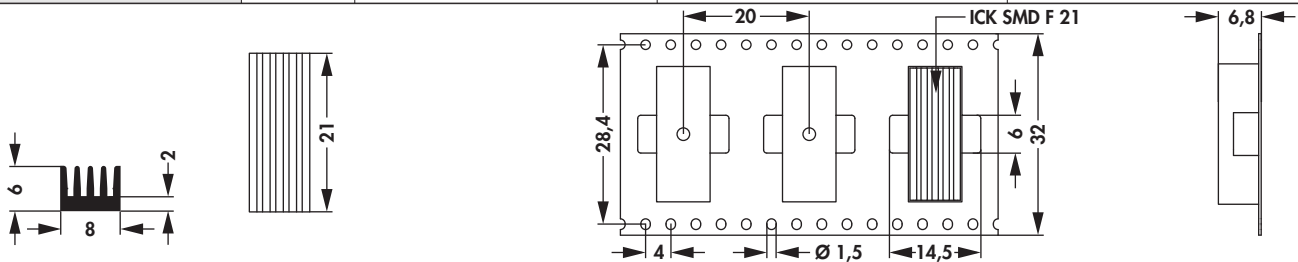

art. no.	R_{th} [K/W]	diameter of tape [mm]	width of belt [mm]	quantity per reel
ICK SMD F 21 ... TR	33	330	32	500

please indicate: ... surface
 SA = black anodised
 MI = solderable surface



heatsink for SMD

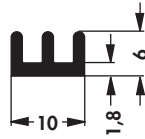

art. no.	↔ [mm]	R_{th} [K/W]	art. no.	↔ [mm]	R_{th} [K/W]
ICK SMD G 8 MI	8	73	ICK SMD G 17 SA	17	41
ICK SMD G 10 ...	10	70	ICK SMD G 19 SA	19	36
ICK SMD G 13 SA	13	61	ICK SMD G 21 ...	21	32

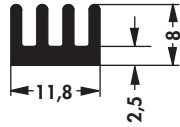

art. no.	↔ [mm]	R_{th} [K/W]	art. no.	↔ [mm]	R_{th} [K/W]
ICK SMD H 8 ...	8	33.0	ICK SMD H 19 SA	19	23.0
ICK SMD H 10 ...	10	29.0	ICK SMD H 25 ...	25	20.0
ICK SMD H 17 ...	17	24.5			

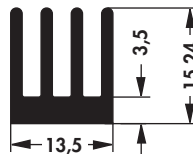

art. no.	↔ [mm]	R_{th} [K/W]	art. no.	↔ [mm]	R_{th} [K/W]
ICK SMD K 8 ...	8	25.6	ICK SMD K 17 ...	17	19.4
ICK SMD K 10 SA	10	23.4	ICK SMD K 19 ...	19	18.0
ICK SMD K 13 ...	13	21.5	ICK SMD K 21 ...	21	16.5

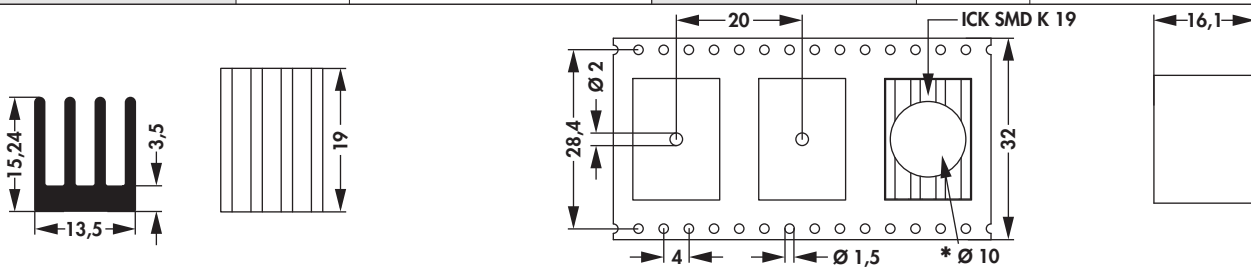

art. no.	R_{th} [K/W]	diameter of tape [mm]	width of belt [mm]	quantity per reel
ICK SMD K 19 ... TR	18	330	32	215



art. no.	↔ [mm]	R_{th} [K/W]	art. no.	↔ [mm]	R_{th} [K/W]
ICK SMD M 8 SA	8	72	ICK SMD M 19 SA	19	35
ICK SMD M 10 SA	10	66	ICK SMD M 21 SA	21	31
ICK SMD M 17 MI	17	40			

please indicate: ... surface
 SA = black anodised
 MI = solderable surface



Heatsink for SMD

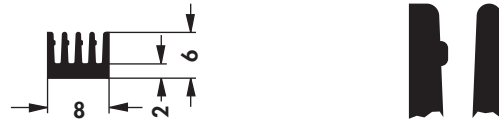

art. no.	width [mm]	R_{th} [K/W]	art. no.	width [mm]	R_{th} [K/W]
ICK SMD N 8 ...	8	74	ICK SMD N 19 ...	19	37
ICK SMD N 10 ...	10	71	ICK SMD N 21 ...	21	33
ICK SMD N 17 ...	17	42	ICK SMD N 26 ...	26	26

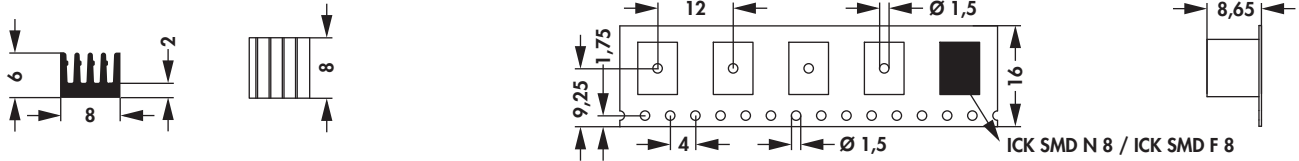

art. no.	R_{th} [K/W]	diameter of tape [mm]	width of belt [mm]	quantity per reel
ICK SMD N 8 ... TR	74	330	16	700

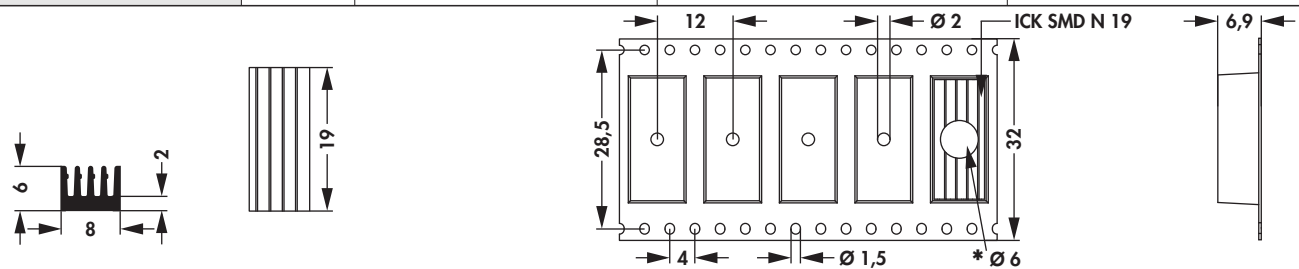

art. no.	R_{th} [K/W]	diameter of tape [mm]	width of belt [mm]	quantity per reel
ICK SMD N 19 ... TR	37	330	32	800



art. no.	width [mm]	R_{th} [K/W]	art. no.	width [mm]	R_{th} [K/W]
ICK SMD O 8 ...	8	73	ICK SMD O 19 ...	19	36
ICK SMD O 10 ...	10	70	ICK SMD O 21 ...	21	31
ICK SMD O 17 ...	17	41	ICK SMD O 25 ...	25	26



please indicate: ... surface
SA = black anodised
MI = solderable surface

Sample box SMD heatsinks

– contains an assortment of SMD heatsinks with anodised and solderable surface as well as thermally conductive glue (**WLK**) and double-sided adhesive thermal foil (**WLF**)



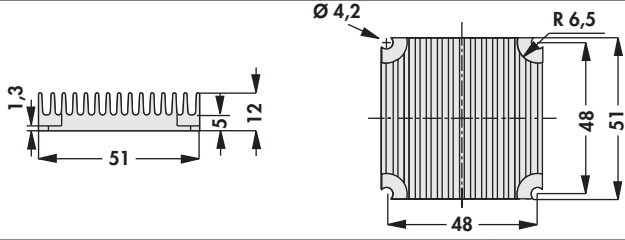
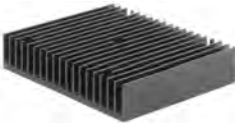
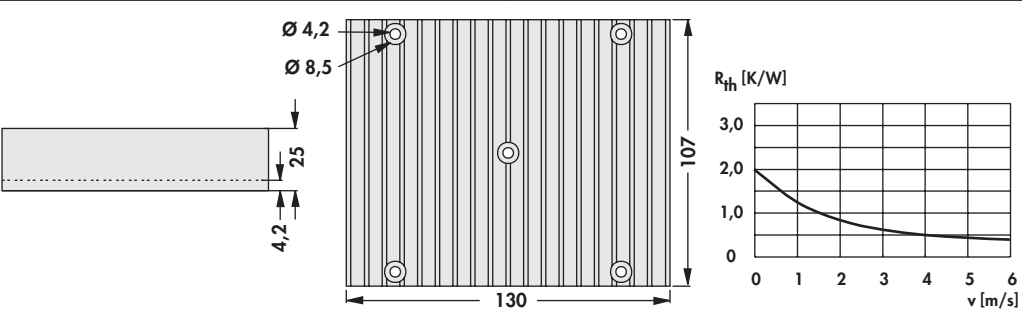

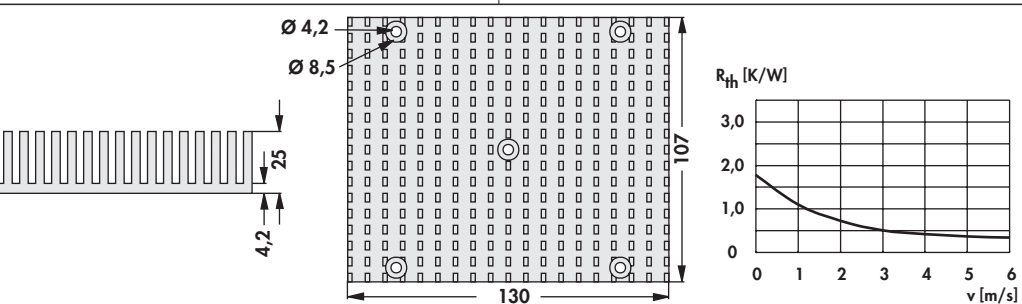
art. no.
ICK SMD BOX 1

		
art. no.	R_{th} [K/W]	suitable for processor type
ICK PPC 51	8.1	Power PC
		
art. no.	R_{th} [K/W]	suitable for processor type
ICK PEN 3 XE	2	Intel® Pentium® III-Xeon™ Slot II Format
		
art. no.	R_{th} [K/W]	suitable for processor type
ICK PEN 3 XE 1	1.8	Intel® Pentium® III-Xeon™ Slot II Format

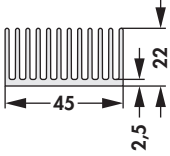
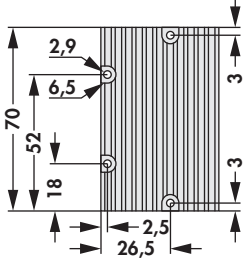
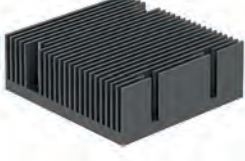
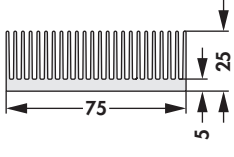
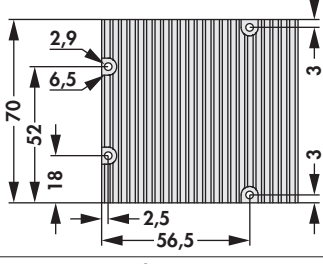
Heatsink specially for Q7 "Embedded-Boards"

		
art. no. ICK EM 22	R_{th} [K/W] 4.4	suitable for processor type μ Q7 Board
		
art. no. ICK EM 25	R_{th} [K/W] 3.9	suitable for processor type Q7 Board

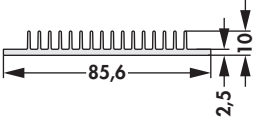
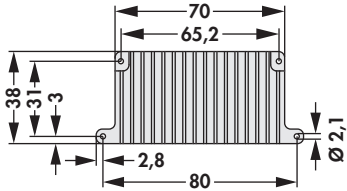
Heatsink specially for Verdin iMX8M

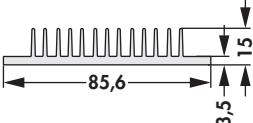
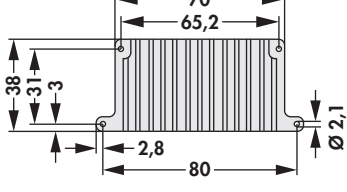
		
art. no. ICK VB 10	R_{th} [K/W] 7.7	suitable for processor type Verdin iMX8M
		
art. no. ICK VB 15	R_{th} [K/W] 6.6	suitable for processor type Verdin iMX8M



Heatsinks especially made for „SMARC Short Module“

For SMARC-sAMX7 module

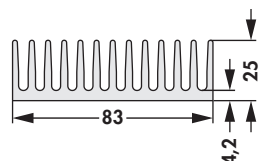
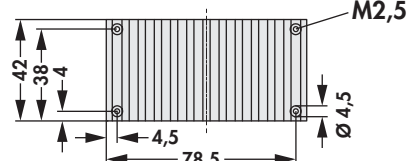
- thermal conductive foil for contacting the processor 1 x GEL 14 20 (19 mm x 19 mm x 2 mm) → E 47
- spacers for mounting on the PCB 4 x AHM 3260 3 → E 106
- heatsink solutions for other module types on request
- customized designs, processing and thermal conductive foils on request

		
<p>art. no.</p>	<p>R_{th} [K/W]</p>	<p>suitable for processor type</p>
<p>ICK SM 25</p>	<p>5.9</p>	<p>SMARC Short Module</p>

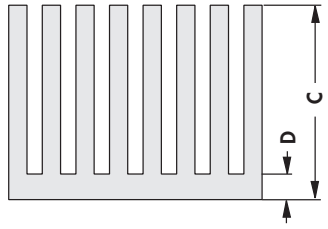
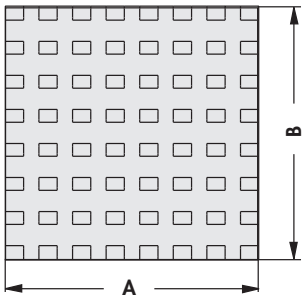
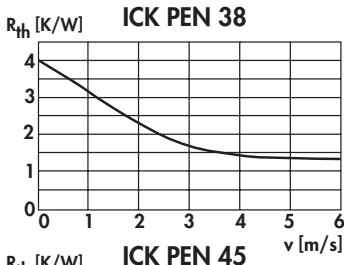
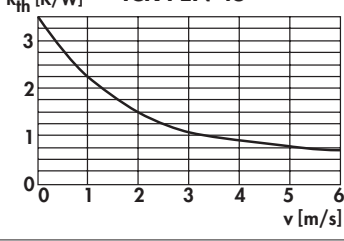
– customer specific versions and modifications on request

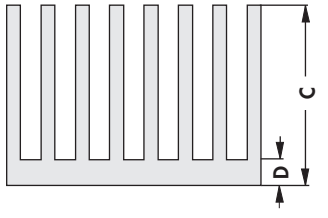
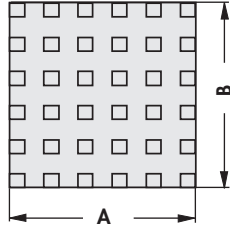
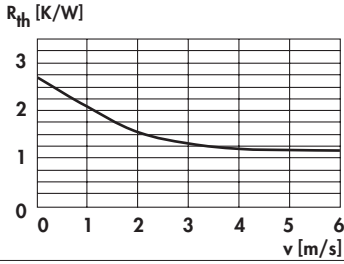
						
						
art. no.	R_{th} [K/W]	suitable for processor type	dim. [mm]			
ICK PEN 38 F	4.0	AMD® K6-III/ IDT W2A/ MMX/ IDT C6/ Intel® Pentium®/ AMD® K6-2	A	B	C	D
ICK PEN 38 W			49.5	49.5	38	5.0
ICK PEN 45 W	3.5		50.0	50.0	45	3.5
						
			art. no.	R_{th} [K/W]	suitable for processor type	dim. [mm]
ICK PRO 40 W	2.7	Intel® Pentium® PRO	A	B	C	D
			65	67.5	40	4.5

F = with double-sided thermally conductive adhesive foil**W** = for thermally conductive adhesive (please order separately) **WLK ...** → E 83 - E 85

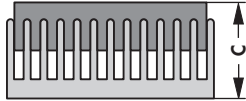
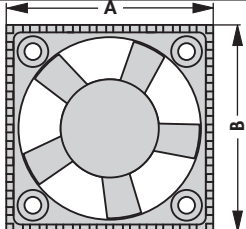
					
art. no.	R _{th} [K/W]	suitable for processor type	dim. [mm]		
			A	B	C
LA ICK 15 x 15 F 05	2.3	universal	37.92	38.10	20
LA ICK 15 x 15 F 12					
LA ICK 17 x 17 F 12	1.6		43.10	43.10	
LA ICK 17 x 17 F 12 A					
LA ICK 17 x 17 W 05					
LA ICK 17 x 17 W 12	1.5		45.70	45.70	
LA ICK 18 x 18 F 12					
LA ICK 18 x 18 W 12	1.4		53.34	53.34	
LA ICK 21 x 21 F 05					
LA ICK 21 x 21 F 12					
LA ICK 21 x 21 W 05					
LA ICK 21 x 21 W 12					

used fans:

5 Volt = **Sepa MFB 25 F 05 L / MFB 40 H 05 / MFB 40 H 05 A;**

12 Volt = **Sepa MFB 25 F 12 / MFB 40 H 12 / MFB 40 H 12 A**

F = with double-sided thermally conductive adhesive foil

W = for thermally conductive adhesive (please order separately) **WLK ...** → E 83 - E 85

A = alarm exit



– easy assembly on ZIF socket by fixing clamp

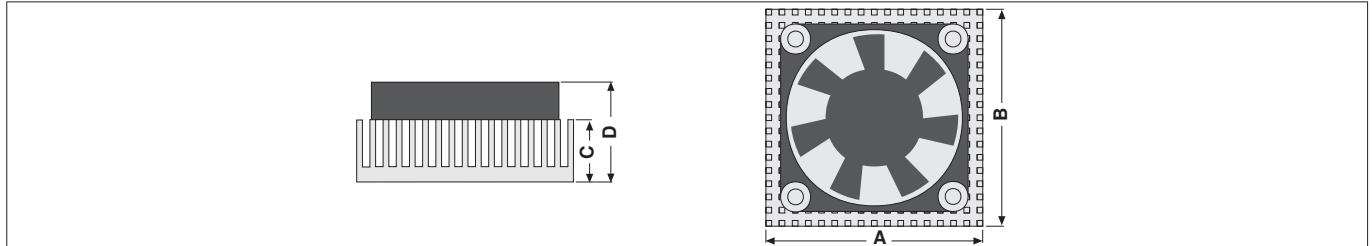

art. no.	R_{th} [K/W]	suitable for processor type	dim. [mm]					
			A	B	C	D		
LA ICK PEN 8 F 05	2.50	AMD® K6-III/ IDT W2A/ Cyrix MII and similar/ MMX/ IDT C6/ Intel® Pentium®/ AMD® K6-2	50.8	50.8	8.00	9.00		
LA ICK PEN 8 W 05					16.51	26.51		
LA ICK PEN 16 W 12	1.20				8.00	18.00		
LA ICK PEN 16 W 12 A					1.60	1.10		
LA ICK PEN 18 W 12	1.10				49.5	49.5	38.00	48.00
LA ICK PEN 38 W 12	0.97				63.5	67.5	25.00	35.00
LA ICK PRO 25 F 12		Intel® Pentium® PRO						

used fans: 5 Volt = **Sepa MFB 50 E 05**; 12 Volt = **Sepa MFB 50 E 12/ Sepa MFB 50 E 12 A**;

LA ICK PEN 8: 5 Volt = **Sepa HFB 44 X 05 A**

F = with double-sided thermally conductive adhesive foil

W = for thermally conductive adhesive (please order separately) **WLK ...** → E 83 - E 85

A = alarm exit

– incl. one-sided adherent thermal foil

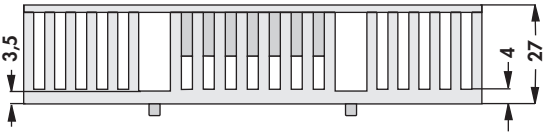
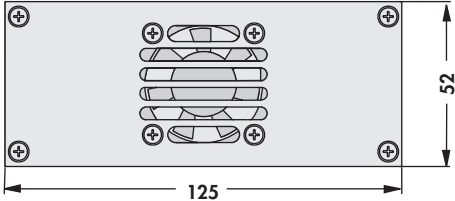
		
art. no.	R_{th} [K/W]	suitable for processor type
LA ICK PEN 2 K 12 ...	1.2	Intel® Pentium® II/ AMD® Athlon®
please indicate: ... accessories (optional) SM = molex connection plug		

utilized fans: 12 Volt = **Sepa MFB 40 H 12**

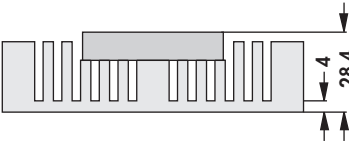
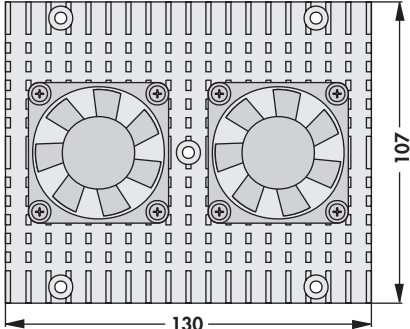
		
art. no.	R_{th} [K/W]	suitable for processor type
LA ICK PEN 3 XE ...	0.8	Intel® Pentium® III-Xeon™
please indicate: ... accessories (optional) A = alarm exit SM = molex connection plug		

fixing method: **SB** = screw fixing

utilized fans: 12 Volt = **Sepa MFB 50 E 12**



molex crimp case series: 2695; molex crimp terminals: 2759

– Sepa-fan 24 h BURN-IN tested

5 Volt Lüfter

	Sepa MFB 25 F 05 L	Sepa MFB 40 H 05	Sepa MFB 40 H 05 A	Sepa MFB 50 E 05	Sepa HFB 44 B 05 A
circuit voltage					
bearing type	double ball bearing	double ball bearing	double ball bearing	double ball bearing	ball bearing
fan dimensions	25x25x10 mm	40x40x10 mm	40x40x10 mm	50x50x10 mm	44x44x6.2 mm
cur. consumpt.	80 mA	90 mA	90 mA	40 mA	60 mA
max. iuitial current	170 mA	250 mA	250 mA	160 mA	140 mA
max. volume flow	46 l/min 2.8 m ³ /h	183 l/min 11 m ³ /h	183 l/min 11 m ³ /h	169 l/min 10.1 m ³ /h	50 l/min 3 m ³ /h
max. static pressure	2.2 mmH ₂ O 22 Pa	3.1mm H ₂ O 30.5 Pa	3.1mm H ₂ O 30.5 Pa	1.6mm H ₂ O 15.6 Pa	2.6mm H ₂ O 25.5 Pa
noise level					
temperature range	-10°C... +70°C	-40°C... +85°C	-40°C... +85°C	-40°C... +85°C	-40°C... +80°C
failure rate (L₁₀)					
MTBF	350.000 h (40°C)	350.000 h (40°C)	350.000 h (40°C)	350.000 h (40°C)	350.000 h (40°C)
weight	8 g	13 g	13 g	19 g	7 g
cases	plastic PBT (UL E54695)	plastic PBT (UL E54695)	plastic PBT (UL E54695)	plastic PBT (UL E54695)	aluminium

12 Volt Lüfter

	Sepa MFB 25 F 12	Sepa MFB 40 H 12	Sepa MFB 40 H 12 A	Sepa MFB 50 E 12
circuit voltage				
bearing type	double ball bearing	double ball bearing	double ball bearing	ball bearing
fan dimensions	25x25x10 mm	40x40x10 mm	40x40x10 mm	50x50x10 mm
cur. consumpt.	70 mA	50 mA	50 mA	50 mA
max. iuitial current	150 mA	130 mA	130 mA	140 mA
max. volume flow	68 l/min 4 m ³ /h	173 l/min 10,4 m ³ /h	173 l/min 10,4 m ³ /h	238 l/min 14.3 m ³ /h
max. static pressure		2.9 mmH ₂ O 28.5 Pa	2.9 mmH ₂ O 28.5 Pa	3.0mm H ₂ O 29.6 Pa
noise level				
temperature range	-40°C... +80°C	-40°C... +85°C	-40°C... +85°C	-40°C... +85°C
failure rate (L₁₀)				
MTBF	350.000 h (40°C)	350.000 h (40°C)	350.000 h (40°C)	350.000 h (40°C)
weight	8 g	13 g	13 g	19 g
cases	plastic PBT (UL E54695)	plastic PBT (UL E54695)	plastic PBT (UL E54695)	plastic PBT (UL E54695)

Fans with pulse output - Technical data of fans with pulse output:

- pulse output for activation of the alarm control
- pulse similar to a square pulse with three times the frequency of the rotor speed
- when the rotor is blocked, the output signal may be L (≤ 0.8 V) or H ($V_{cc}-1$ V)
- the pulse output must not be connected to GND or V_{cc} withoutb protective resistor (> 10 K)
- in order to avoid short circuits, the pulse output not being used must be insulated



Finger shaped heatsinks for power semiconductors

- specially compatible for power semiconductors in a TO-case
- made as a bent sheet metal part or die cast heatsink made of aluminium
- aligned heatsink contours for the best heat dissipation
- direct screwing of the component to the heatsink on the PCB



Attachable heatsinks

- made of aluminium or copper material
- solderable surface coating
- integrated spring clip for easy and fast mounting of the transistor
- secure hold of the component due to optimized spring force and geometry
- customer specific version upon request

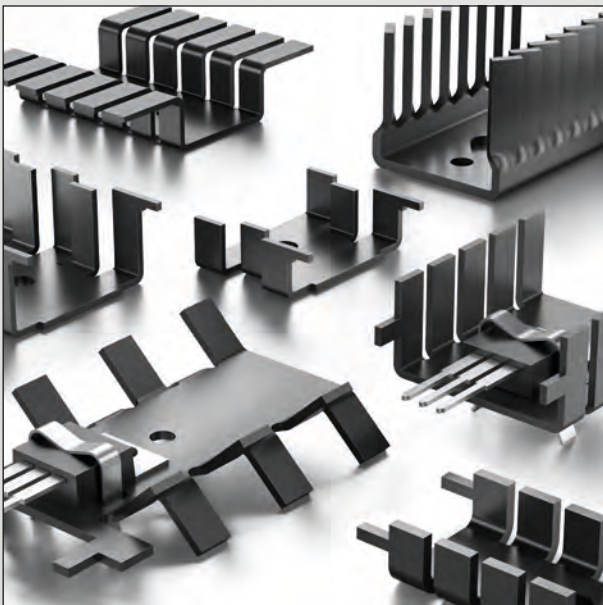

Finger shaped heatsinks for transistors

- effective heat dissipation of transistors
- efficient radiation of heat at a horizontal or vertical mounting position
- component fastening by means of screws or special transistor retaining springs
- solder mounting by means of integrated solder pins and solderable surfaces

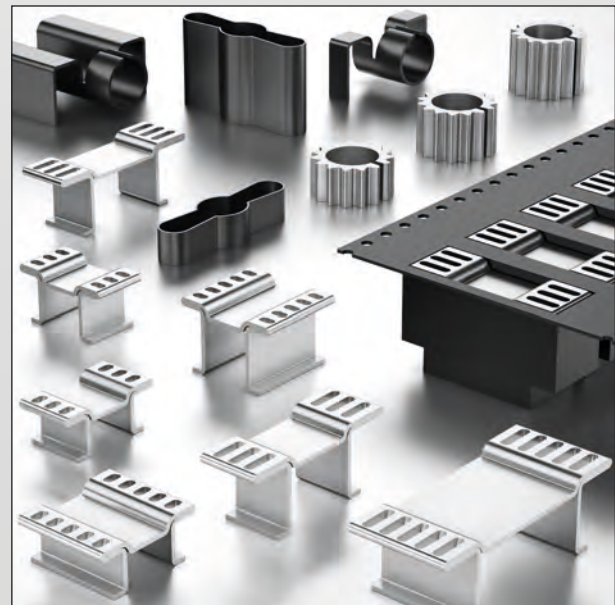



Miniature heatsinks

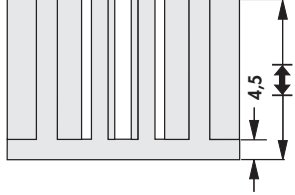
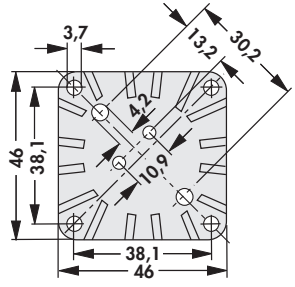

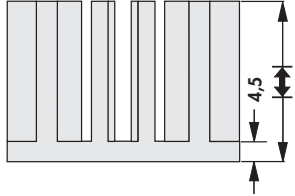
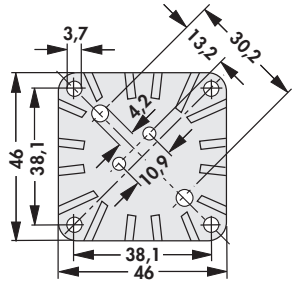

- for TO 5, SOT 82, D PAK and similar semiconductors
- made of aluminium, phosphorus bronze or copper
- simple mounting by direct plugging or soldering of the heatsink
- special types of packaging such as tape & reel, magazine or tray upon request
- versions and designs for your application

			
art. no.	\pm [mm]	R_{th} [K/W]	\emptyset
FK 318 SA 3	31.8	4.8	TO 3
material:	die-casting aluminium		
surface:	black lacquered		

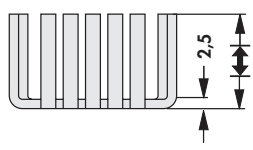
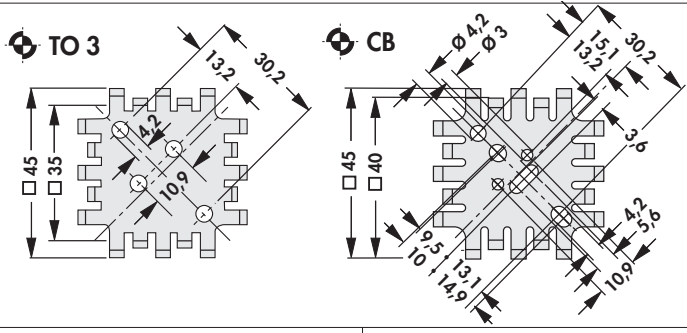
– packing unit = 24 pieces

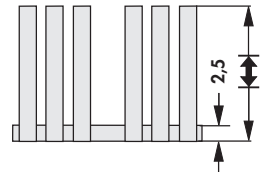
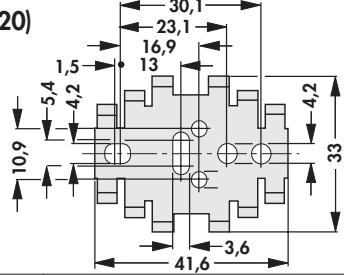
			
art. no.	\pm [mm]	R_{th} [K/W]	\emptyset
FK 254 1 SA	25.4	5.4	without
FK 254 1 SA 3			TO 3
FK 318 1 SA	31.8	4.4	without
FK 318 1 SA 3			TO 3
material:	aluminium, EN AW 1050 A, cold extruded part		
surface:	black anodised		

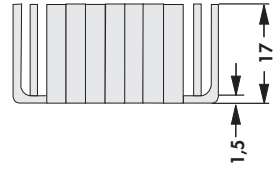
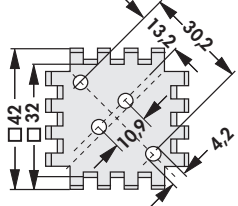
			
art. no.	\pm [mm]	R_{th} [K/W]	\emptyset
FK 201 SA	25.4	6	without
FK 201 SA 3			TO 3
FK 201 SA CB			CB
FK 202 SA	12.7	8	without
FK 202 SA 3			TO 3
FK 202 SA CB			CB
material:	aluminium		
surface:	black anodised		

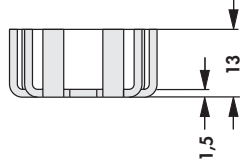
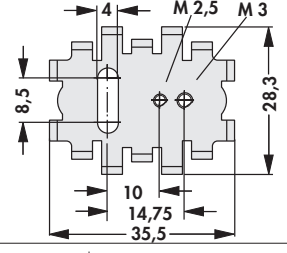



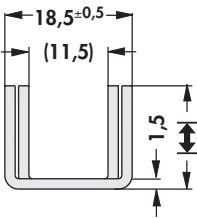
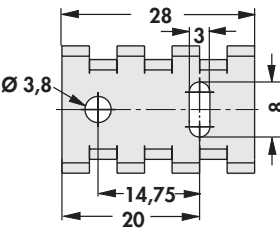
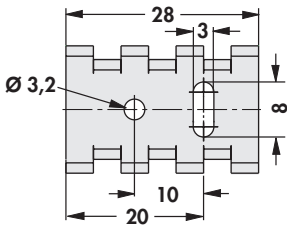
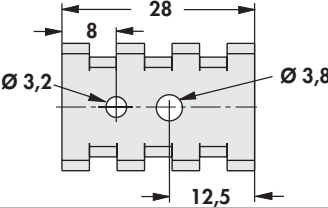
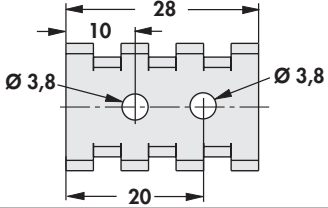



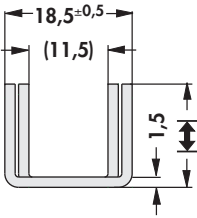
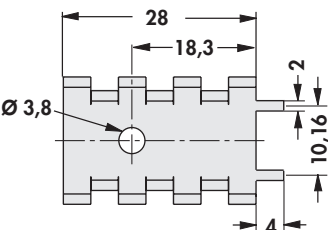
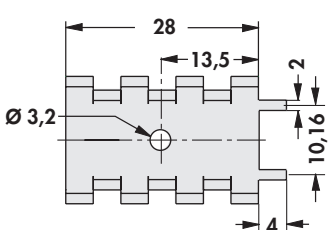

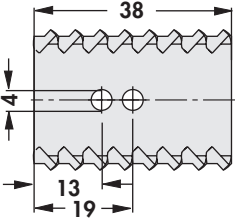
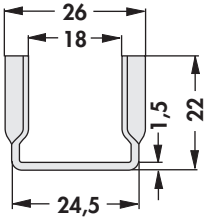
		\varnothing L (TO 3 + SOT 9 + TO 66 + SOT 32 + TO220)	
art. no.	\pm [mm]	R_{th} [K/W]	\varnothing
FK 205 SA L	31.8	9.0	L
FK 206 SA L	25.4	10.5	
FK 207 SA L	19.1	12.0	
FK 208 SA L	12.7	14.0	
		FK 223 SA 3	
art. no.	R_{th} [K/W]	\varnothing	
FK 223 SA	6.8	without	
FK 223 SA 3		TO 3	
FK 223 SA CB		CB	
			
art. no.	R_{th} [K/W]	\varnothing	
FK 217 SA CB 2	16	CB 2 (SOT 32; TO 220)	
material:	aluminium		
surface:	black anodised		

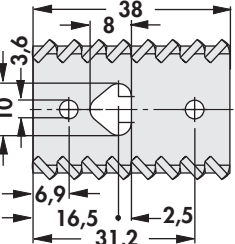
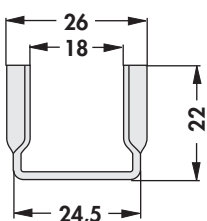

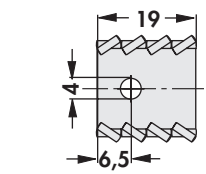
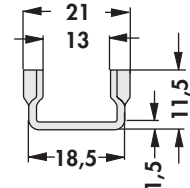

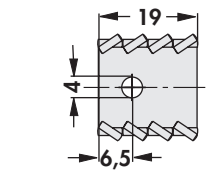
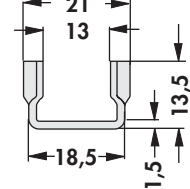

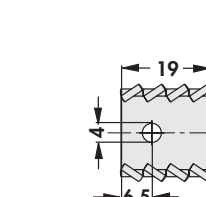
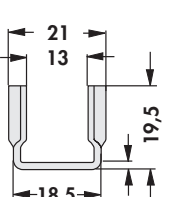

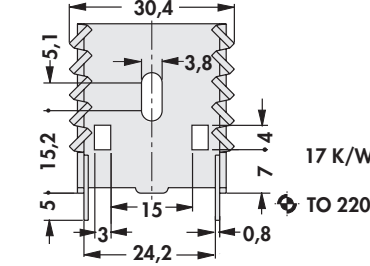
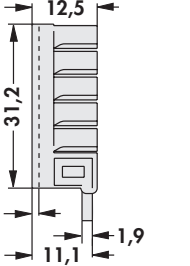

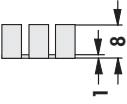
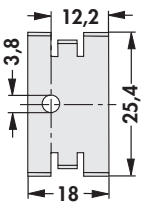
– for semiconductor screw-assembly, horizontal

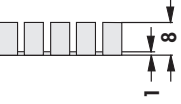
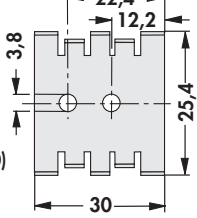

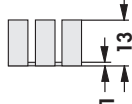
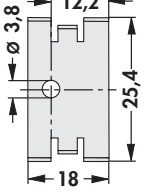

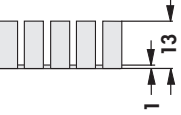
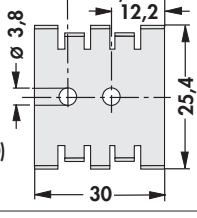

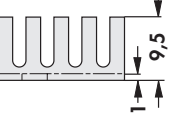
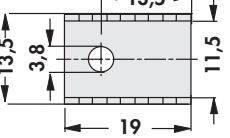

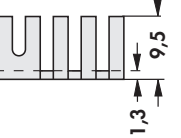
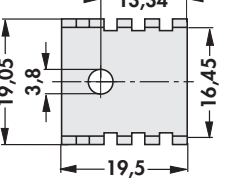

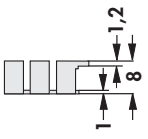
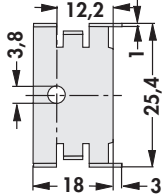

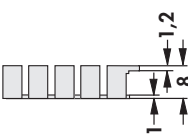
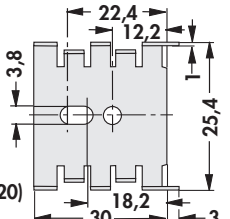
					
					
	art. no.	\pm [mm]	R_{th} [K/W]	\diamond	
	FK 234 SA L 1	15	17	TO 220	
	FK 234 SA L 2			SOT 32	
FK 234 SA L 3	CB				
FK 234 SA L 4					
material:	aluminium				
surface:	black anodised				

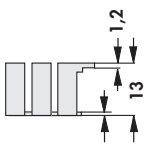
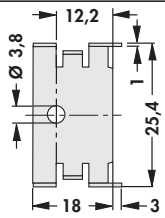

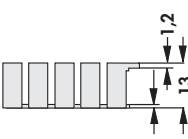
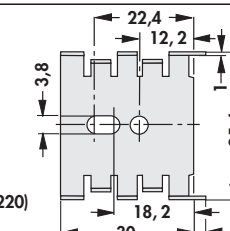
– for semiconductor screw-assembly, vertical

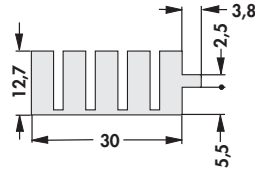
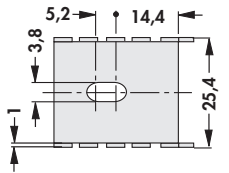

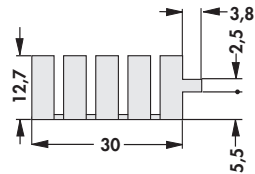
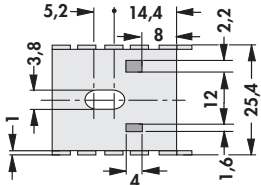

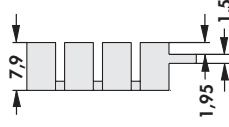
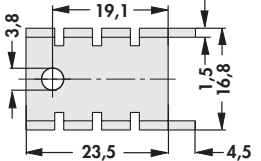

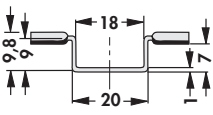
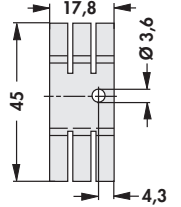

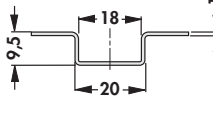
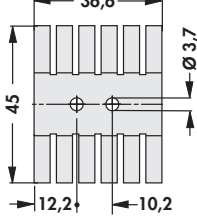
				
	art. no.	\pm [mm]	R_{th} [K/W]	\diamond
	FK 235 ... L 1	15	16	TO 220
	FK 235 ... L 2			SOT 32
	please indicate:	... surface SA = black anodised MI = solderable surface		
material:	aluminium			

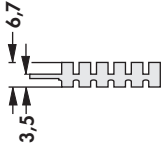

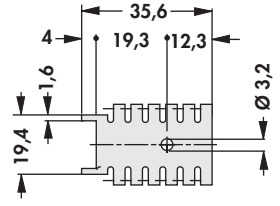

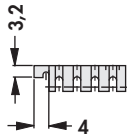
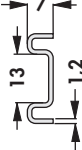
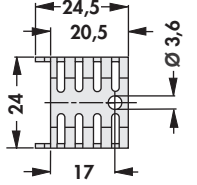

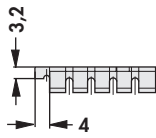
art. no. FK 225 SA L 1			9,9 K/W TO 220	
art. no. FK 225 SA L 2			9,9 K/W TO 220	
art. no. FK 228 SA L 1			30 K/W TO 220	
art. no. FK 229 SA L 1			27 K/W TO 220	
art. no. FK 230 SA L 1			21 K/W TO 220	
material:		aluminium		
surface:		black anodised		
art. no. FK 249 SA 220				
material:		aluminium		
surface:		black passivated, solder pins tin plated		

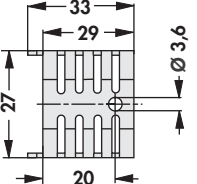
<p>art. no.</p> <p>FK 209 SA 32</p>			<p>25 K/W</p> <p>⊗ SOT 32</p>	
<p>available without hole pattern as well</p>				
<p>art. no.</p> <p>FK 210 SA CB</p>			<p>18 K/W</p> <p>⊗ CB (SOT 32 + TO 220)</p>	
<p>available without hole pattern as well</p>				
<p>art. no.</p> <p>FK 213 SA 32</p>			<p>21 K/W</p> <p>⊗ SOT 32</p>	
<p>available without hole pattern as well</p>				
<p>art. no.</p> <p>FK 214 SA CB</p>			<p>15 K/W</p> <p>⊗ CB (SOT 32 + TO 220)</p>	
<p>available without hole pattern as well</p>				
<p>art. no.</p> <p>FK 231 SA 220</p>			<p>24 K/W</p> <p>⊗ TO 220</p>	
<p>art. no.</p> <p>FK 239 SA 32</p>			<p>24 K/W</p> <p>⊗ SOT 32</p>	
<p>material:</p> <p>surface:</p>	<p>aluminium</p> <p>black anodised</p>			

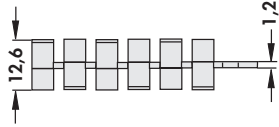
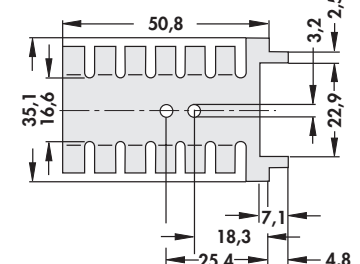
art. no. FK 211 32 ...			25 K/W SOT 32	
available without hole pattern as well				
art. no. FK 212 CB ...			18 K/W CB (SOT 32 + TO 220)	
available without hole pattern as well				
art. no. FK 215 32 ...			21 K/W SOT 32	
available without hole pattern as well				
art. no. FK 216 CB ...			15 K/W CB (SOT 32 + TO 220)	
available without hole pattern as well				
art. no. FK 222 ...			20 K/W TO 220	
available without hole pattern as well				
art. no. FK 222 THF ...			20 K/W TO 220	
art. no. FK 247 220 ...			22 K/W TO 220	
please indicate: ... surface SA = black anodised MI = solderable surface				
material:	aluminium			

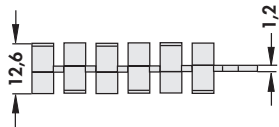
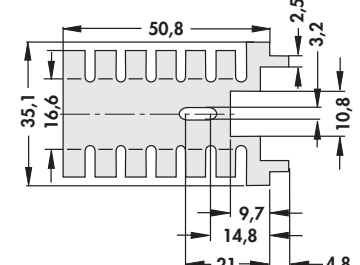
<p>art. no.</p> <p>FK 227 SA L 1</p>		 <p>9,8 9 18 20 7 1</p>	<p>22 K/W</p> <p>TO 220</p>  <p>17,8 45 Ø 3,6 4,3</p>
<p>art. no.</p> <p>FK 238 SA L 1</p>		 <p>9,5 18 20 1</p>	<p>12 K/W</p> <p>TO 220</p>  <p>36,6 45 Ø 3,7 12,2 10,2</p>
<p>material:</p>		<p>aluminium</p>	
<p>surface:</p>		<p>black anodised</p>	

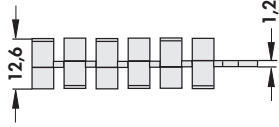
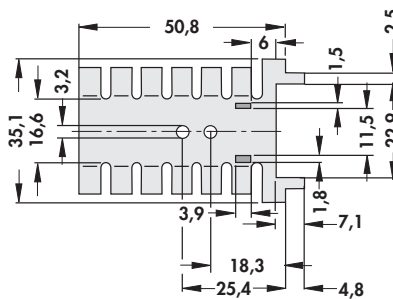
<p>art. no.</p> <p>FK 218 32 ...</p>		 <p>6,7 3,5</p>  <p>22 1,2</p>	<p>21 K/W</p> <p>SOT 32 TO 220</p>  <p>35,6 4 19,3 12,3 19,4 1,6 Ø 3,2</p>
<p>art. no.</p> <p>FK 232 220 ...</p>		 <p>3,2 4</p>  <p>7 13 1,2</p>	<p>21 K/W</p> <p>TO 220</p>  <p>24,5 20,5 24 17 Ø 3,6</p>
<p>art. no.</p> <p>FK 233 220 ...</p>		 <p>3,2 4</p>  <p>7 16 1,2</p>	<p>20,2 K/W</p> <p>TO 220</p>  <p>33 29 27 20 Ø 3,6</p>
<p>please indicate:</p>		<p>... surface SA = black anodised MI = solderable surface</p>	
<p>material:</p>		<p>aluminium</p>	

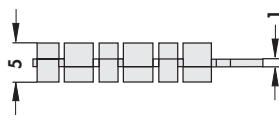
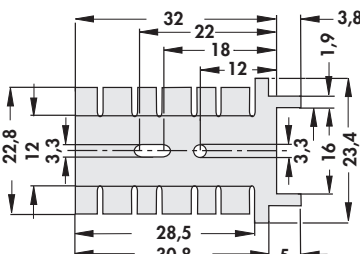
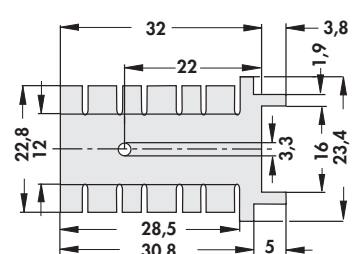
		
art. no. FK 219 CB 1 ...	R_{th} [K/W] 14	Φ CB 1 (TO 220)
		
art. no. FK 219 CB 2 ...	R_{th} [K/W] 14	Φ CB 2 (TO 220)
		
art. no. FK 219 CB 3 ...	R_{th} [K/W] 14	Φ CB 3 (TO 220)
		<div style="display: flex; justify-content: space-around;"> <div data-bbox="763 1366 1120 1653"> <p>FK 236 CB ...</p>  </div> <div data-bbox="1136 1366 1494 1653"> <p>FK 236 220 ...</p>  </div> </div>
art. no.	R_{th} [K/W]	Φ
FK 236 220 ...	18	TO 220
FK 236 CB ...	18	CB
please indicate: ... surface SA = black anodised MI = solderable surface		
material:	aluminium	

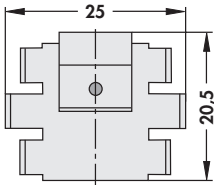
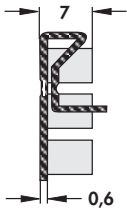
		
art. no.	R_{th} [K/W]	⚡
FK 220 SA 220	25	TO 220
material:	aluminium	
surface:	black anodised	

– for transistors with thin bottom thickness (0.5 mm)

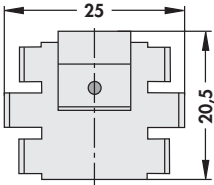
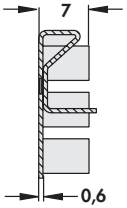
		
art. no.	R_{th} [K/W]	⚡
FK 258 SA 220	25	TO 220
material:	aluminium	
surface:	black anodised	

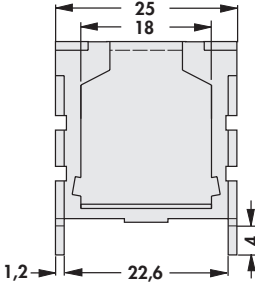
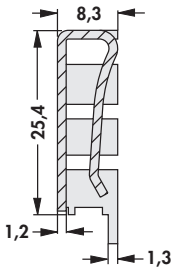
		
art. no.	R_{th} [K/W]	⚡
FK 224 ... P SIP	18	P SIP
please indicate:	... surface	
	SA = black anodised	
	MI = solderable surface	
material:	aluminium	

A

Attachable heatsinks

B

C

D

E

F

G

H

I

K

L

M

N

	FK 224 ... 218 1		FK 224 ... 218 2		
	FK 224 ... 220 1		FK 224 ... 220 2		
art. no.	R_{th} [K/W]	\varnothing	art. no.	R_{th} [K/W]	\varnothing
FK 224 ... 218 1	18	TO 218	FK 224 ... 220 1	18	TO 220
FK 224 ... 218 2			FK 224 ... 220 2		
please indicate: ... surface SA = black anodised MI = solderable surface					
material:		aluminium			
art. no.					
FK 241 SA 218 V	with tin-plated soldering lug for direct soldering onto circuit board, for vertical installation				
art. no.					
FK 248 SA 220					
material:		aluminium			
surface:		black anodised, solder pins tin plated			









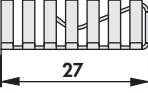
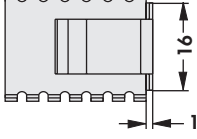
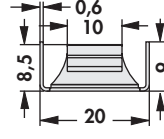

C 11

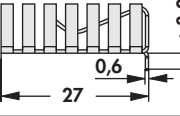
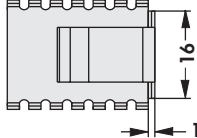
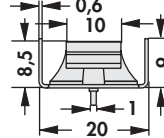
Technical introduction

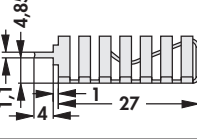
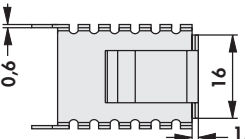
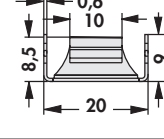
→ A 2 - 8

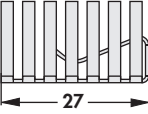
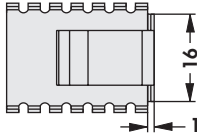
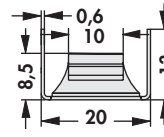

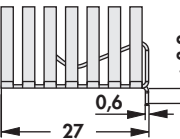
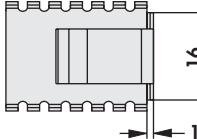
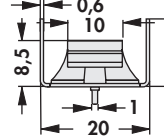

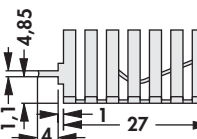
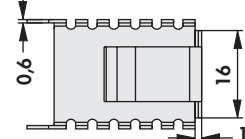
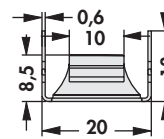



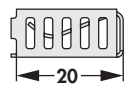
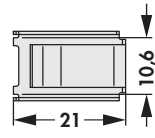
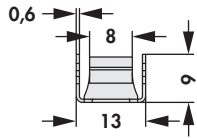

Attachable heatsinks

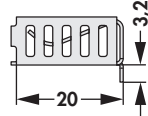
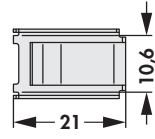
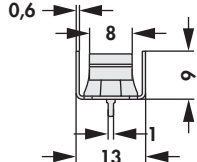

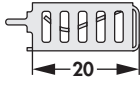
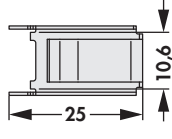
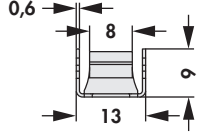

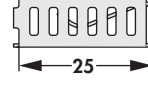
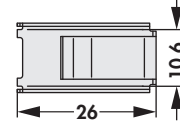
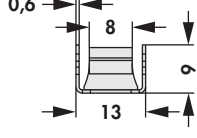

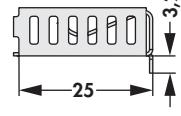
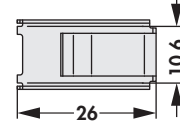
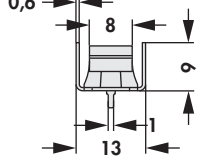

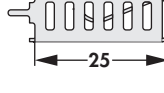
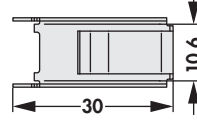
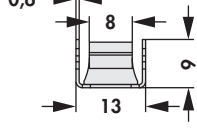
- universal clip on heatsinks for type TO 218, TO 229, TO 247, TO 248, SIP-Mulitwatt and similar
- easy assembly by pushing the heatsink onto the component
- for vertical and horizontal fastening by soldering
- fin height variations on request
- special design accord. to customized specification

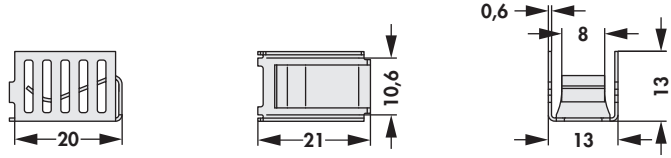
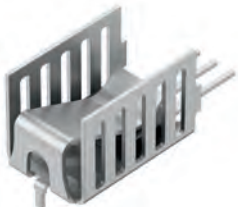
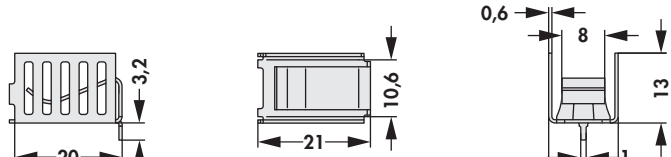
art. no. FK 245 MI 247 O		20,2 K/W 		
without soldering lug				
art. no. FK 245 MI 247 H		20,5 K/W 		
with soldering lug for horizontal mounting				
art. no. FK 245 MI 247 V		19,7 K/W 		
with soldering lug for vertical mounting				
art. no. FK 243 MI 247 O		18,4 K/W 		
without soldering lug				
art. no. FK 243 MI 247 H		19 K/W 		
with soldering lug for horizontal mounting				
art. no. FK 243 MI 247 V		18,4 K/W 		
with soldering lug for vertical mounting				
material:	copper (Cu)			
surface:	solderable surface			
material thickness:	0.6 mm			

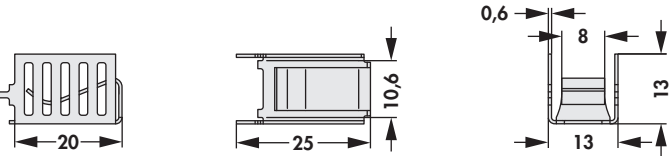

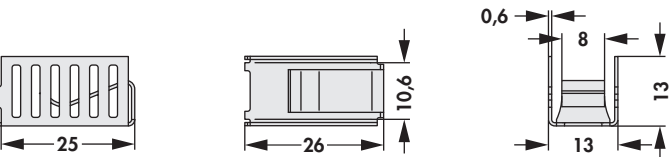

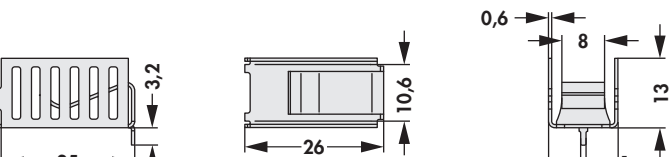

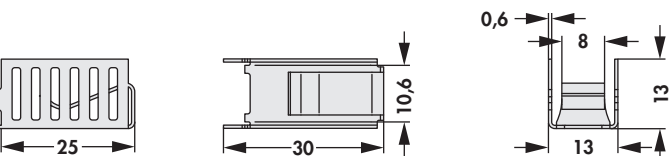

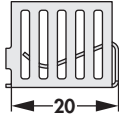
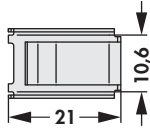
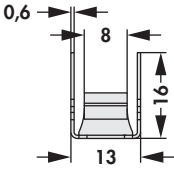

Attachable heatsink

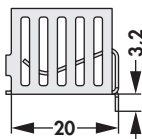
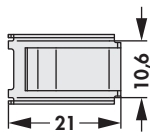
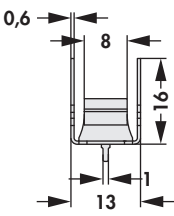

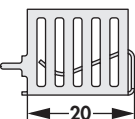
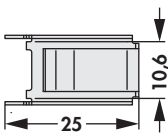
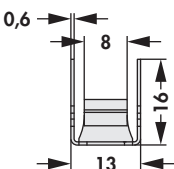

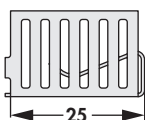
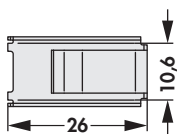
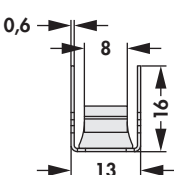

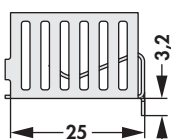
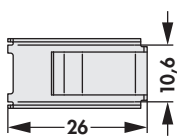
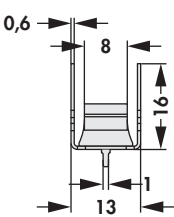

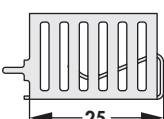
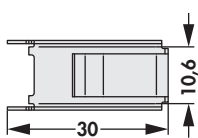
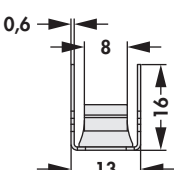

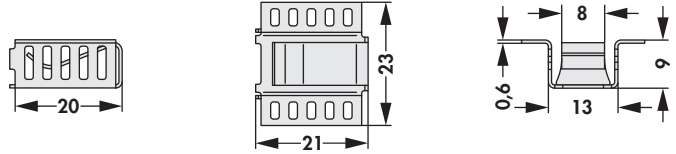
- universal clip-on heatsinks for design TO 220 and similar
- integrated clamp geometry for a secure fixing of the device
- angled designs with enlarged surface
- modifications and special designs according to customer's specifications

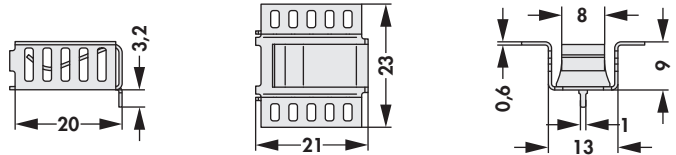
art. no.  FK 259 MI 220 O	24,4 K/W   
art. no.  FK 259 MI 220 H	24,7 K/W   
art. no.  FK 259 MI 220 V	23,9 K/W   
art. no.  FK 260 MI 220 O	24,1 K/W   
art. no.  FK 260 MI 220 H	24,4 K/W   
art. no.  FK 260 MI 220 V	23,6 K/W   
material: surface: material thickness:	copper (Cu) solderable surface 0.6 mm

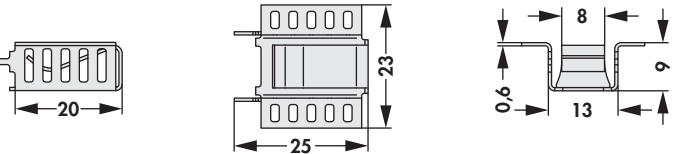

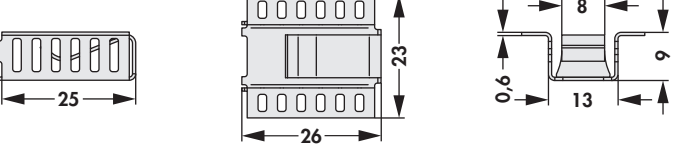

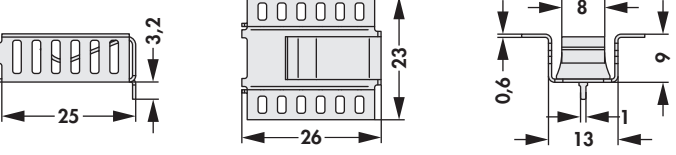

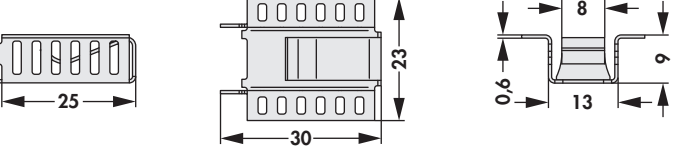

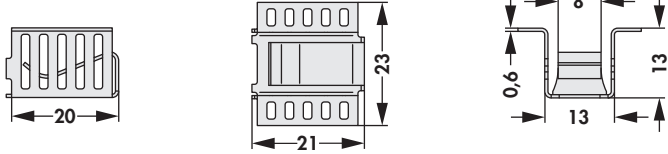

<p>art. no.</p> <p>FK 261 MI 220 O</p>		<p>23,8 K/W</p> 
<p>art. no.</p> <p>FK 261 MI 220 H</p>		<p>24,1 K/W</p> 
<p>art. no.</p> <p>FK 261 MI 220 V</p>		<p>23,3 K/W</p> 
<p>art. no.</p> <p>FK 262 MI 220 O</p>		<p>23,5 K/W</p> 
<p>art. no.</p> <p>FK 262 MI 220 H</p>		<p>23,8 K/W</p> 
<p>art. no.</p> <p>FK 262 MI 220 V</p>		<p>23 K/W</p> 
<p>material:</p>		<p>copper (Cu)</p>
<p>surface:</p>		<p>solderable surface</p>
<p>material thickness:</p>		<p>0.6 mm</p>

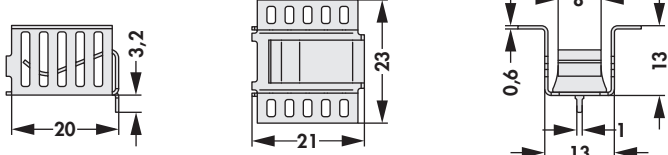

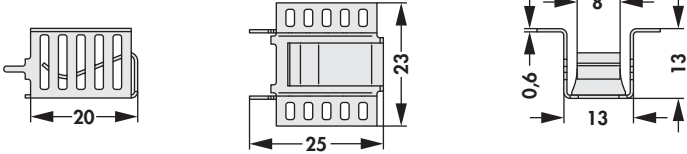

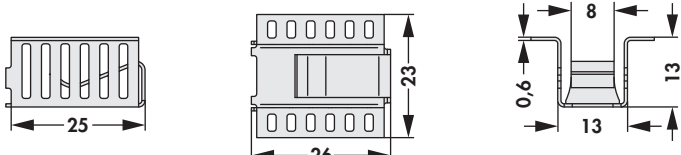

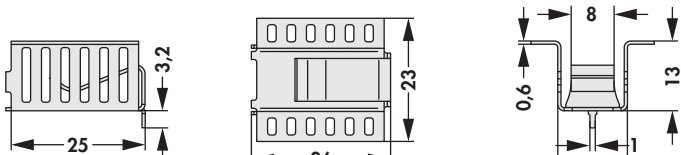

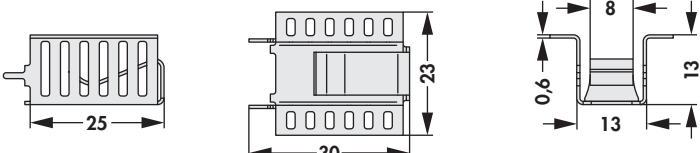

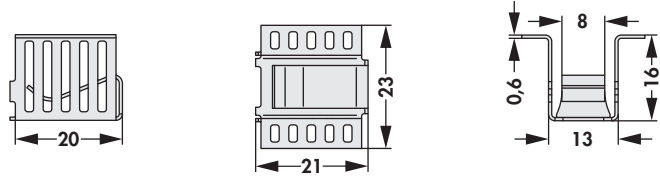
Attachable heatsink

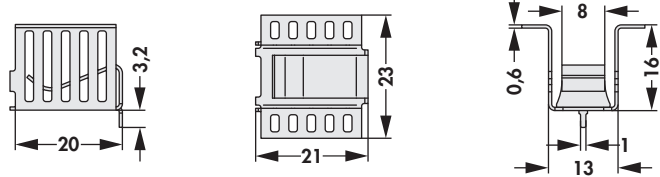
art. no. FK 263 MI 220 O		23,2 K/W 		
art. no. FK 263 MI 220 H		23,5 K/W 		
art. no. FK 263 MI 220 V		22,7 K/W 		
art. no. FK 264 MI 220 O		22,9 K/W 		
art. no. FK 264 MI 220 H		23,2 K/W 		
art. no. FK 264 MI 220 V		22,4 K/W 		
material:	copper (Cu)			
surface:	solderable surface			
material thickness:	0.6 mm			

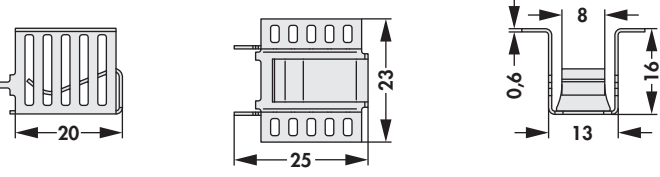
<p>art. no.</p> <p>FK 265 MI 220 O</p>		<p>22,5 K/W</p> 
<p>art. no.</p> <p>FK 265 MI 220 H</p>		<p>22,8 K/W</p> 
<p>art. no.</p> <p>FK 265 MI 220 V</p>		<p>22 K/W</p> 
<p>art. no.</p> <p>FK 266 MI 220 O</p>		<p>22,2 K/W</p> 
<p>art. no.</p> <p>FK 266 MI 220 H</p>		<p>22,5 K/W</p> 
<p>art. no.</p> <p>FK 266 MI 220 V</p>		<p>21,7 K/W</p> 
<p>material:</p>		<p>copper (Cu)</p>
<p>surface:</p>		<p>solderable surface</p>
<p>material thickness:</p>		<p>0.6 mm</p>

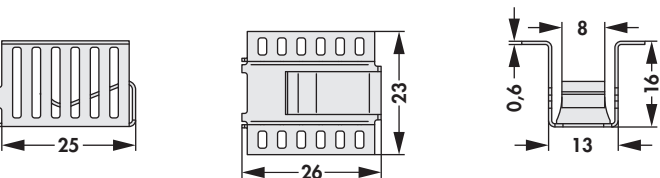

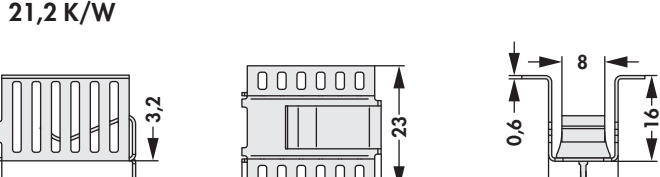

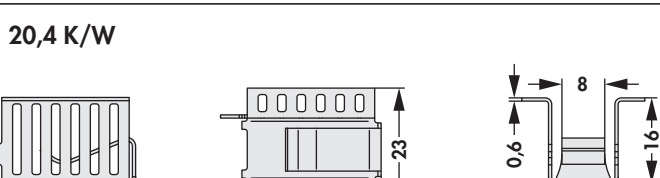



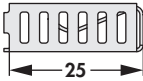
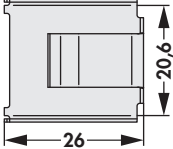
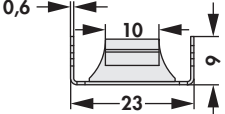

Attachable heatsink

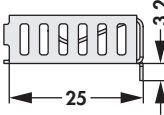
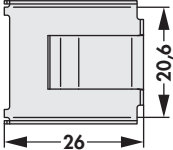
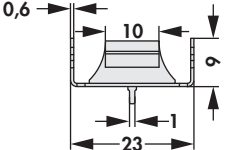

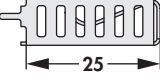
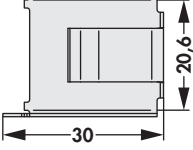
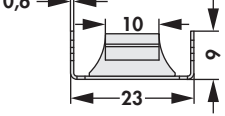

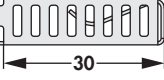
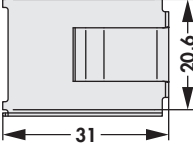
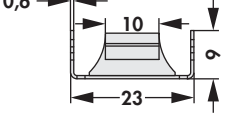

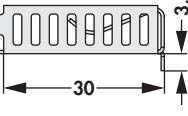
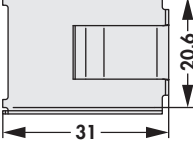
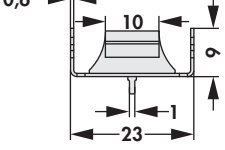

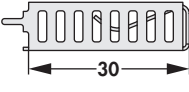
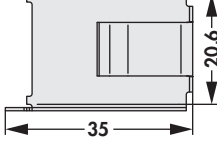
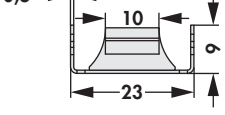

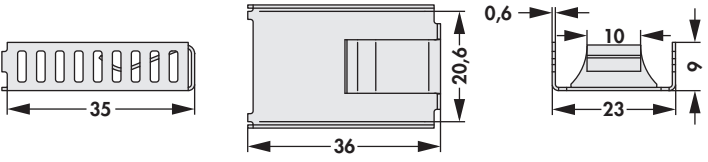
art. no. FK 267 MI 220 O		21,9 K/W 	
art. no. FK 267 MI 220 H		22,2 K/W 	
art. no. FK 267 MI 220 V		21,4 K/W 	
art. no. FK 268 MI 220 O		21,6 K/W 	
art. no. FK 268 MI 220 H		21,9 K/W 	
art. no. FK 268 MI 220 V		21,1 K/W 	
material:		copper (Cu)	
surface:		solderable surface	
material thickness:		0.6 mm	

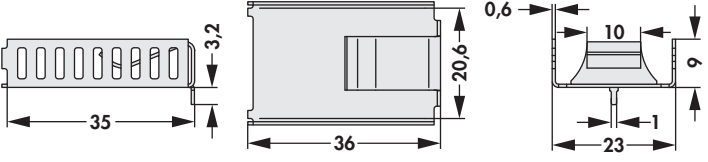

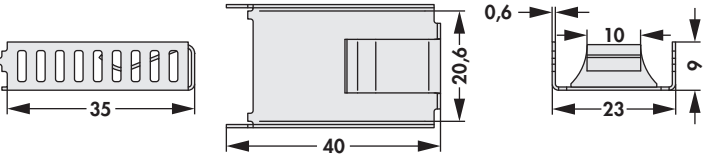

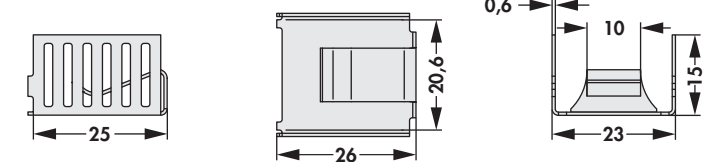

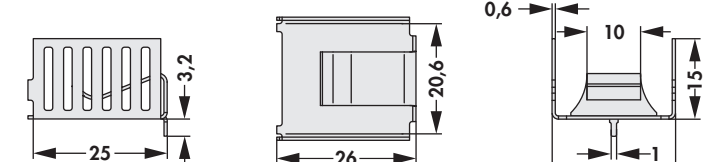

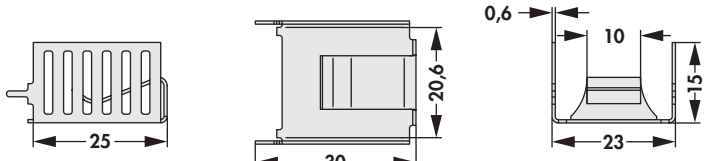

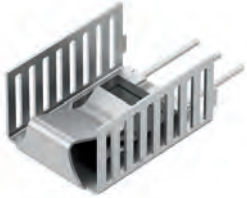
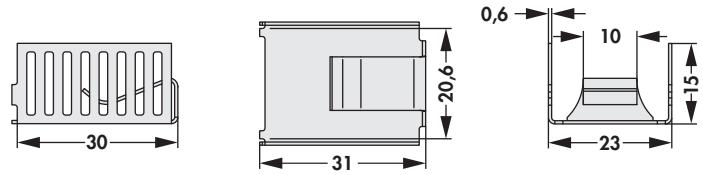
<p>art. no.</p> <p>FK 269 MI 220 O</p>		<p>21,2 K/W</p> 
<p>art. no.</p> <p>FK 269 MI 220 H</p>		<p>21,5 K/W</p> 
<p>art. no.</p> <p>FK 269 MI 220 V</p>		<p>20,7 K/W</p> 
<p>art. no.</p> <p>FK 270 MI 220 O</p>		<p>20,9 K/W</p> 
<p>art. no.</p> <p>FK 270 MI 220 H</p>		<p>21,2 K/W</p> 
<p>art. no.</p> <p>FK 270 MI 220 V</p>		<p>20,4 K/W</p> 
<p>material:</p>		<p>copper (Cu)</p>
<p>surface:</p>		<p>solderable surface</p>
<p>material thickness:</p>		<p>0.6 mm</p>

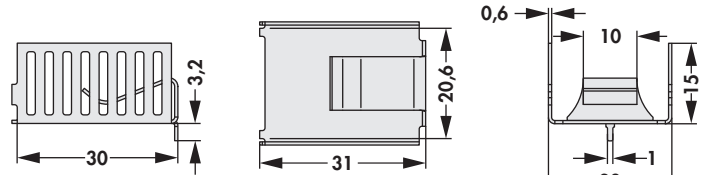

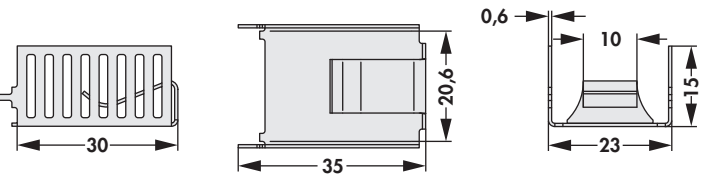

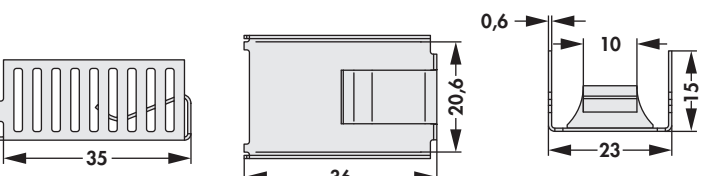

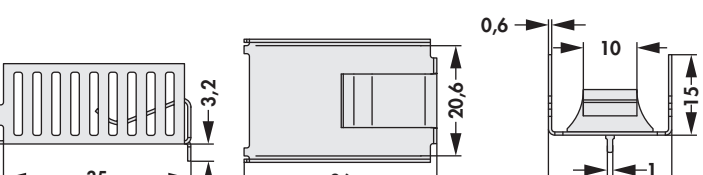

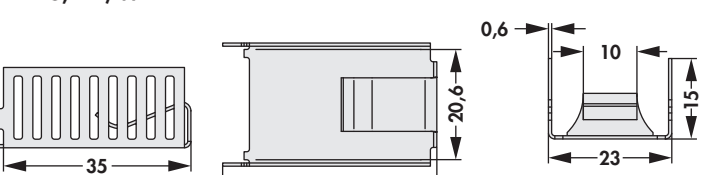

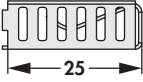
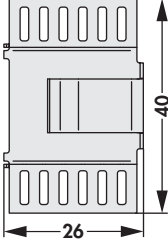
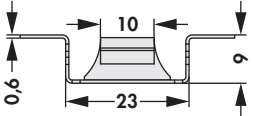
Attachable heatsink

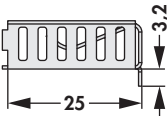
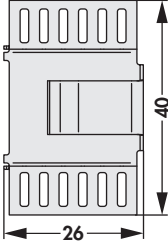
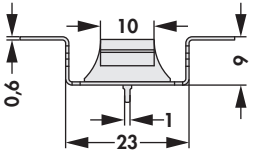

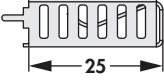
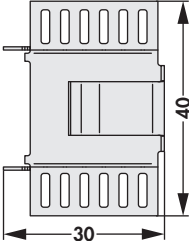
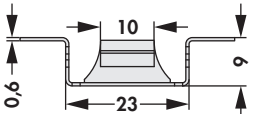

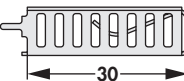
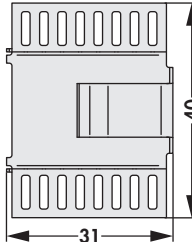
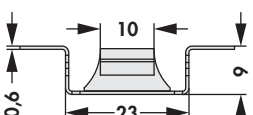

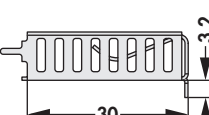
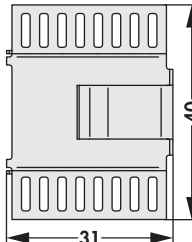
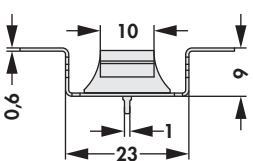

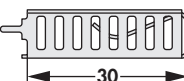
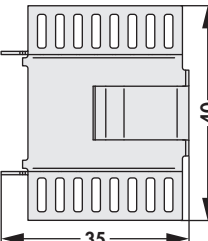
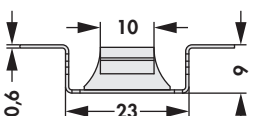

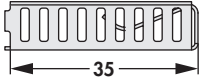
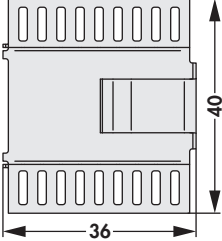
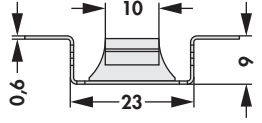
- universal clip-on heatsinks for design TO 218, TO 247, TO 248, SIP-Multiwatt and similar
- integrated clamp geometry for a secure fixing of the device
- angled designs with enlarged surface
- modifications and special designs according to customer's specifications

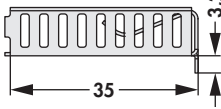
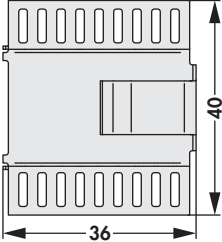
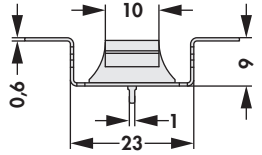

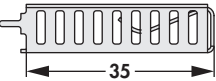
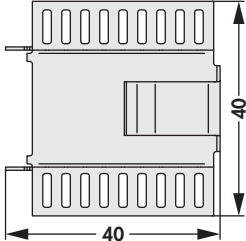
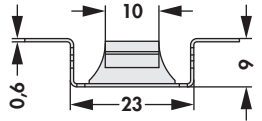

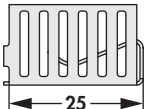
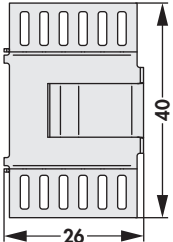
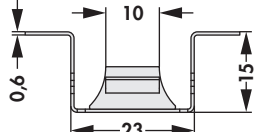

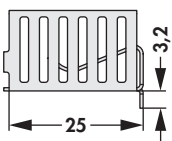
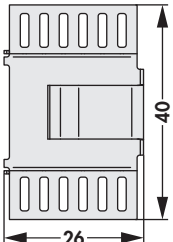
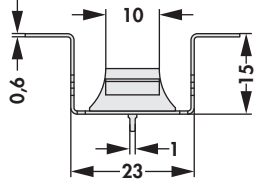

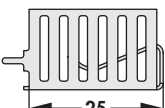
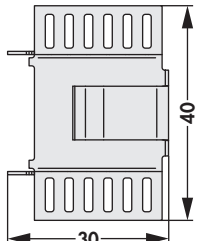
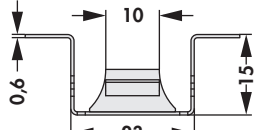

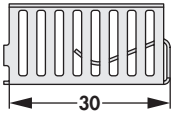
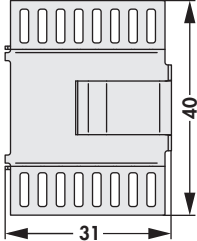
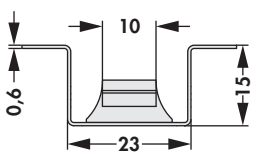
art. no.  FK 271 MI 247 O	19,9 K/W   
art. no.  FK 271 MI 247 H	20,2 K/W   
art. no.  FK 271 MI 247 V	19,4 K/W   
art. no.  FK 272 MI 247 O	19,6 K/W   
art. no.  FK 272 MI 247 H	19,9 K/W   
art. no.  FK 272 MI 247 V	19,1 K/W   
material: surface: material thickness:	copper (Cu) solderable surface 0.6 mm

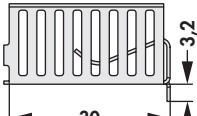
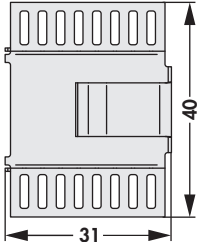
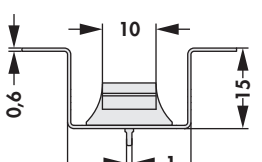
<p>art. no.</p> <p>FK 273 MI 247 O</p>		<p>19,3 K/W</p> 
<p>art. no.</p> <p>FK 273 MI 247 H</p>		<p>19,6 K/W</p> 
<p>art. no.</p> <p>FK 273 MI 247 V</p>		<p>18,8 K/W</p> 
<p>art. no.</p> <p>FK 274 MI 247 O</p>		<p>19,2 K/W</p> 
<p>art. no.</p> <p>FK 274 MI 247 H</p>		<p>19,5 K/W</p> 
<p>art. no.</p> <p>FK 274 MI 247 V</p>		<p>18,7 K/W</p> 
<p>material:</p>		<p>copper (Cu)</p>
<p>surface:</p>		<p>solderable surface</p>
<p>material thickness:</p>		<p>0.6 mm</p>

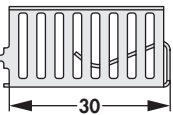
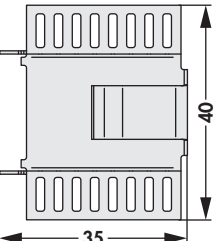
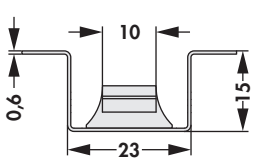
art. no. FK 275 MI 247 O		18,9 K/W 
art. no. FK 275 MI 247 H		19,2 K/W 
art. no. FK 275 MI 247 V		18,4 K/W 
art. no. FK 276 MI 247 O		18,6 K/W 
art. no. FK 276 MI 247 H		18,9 K/W 
art. no. FK 276 MI 247 V		18,1 K/W 
material:		copper (Cu)
surface:		solderable surface
material thickness:		0.6 mm

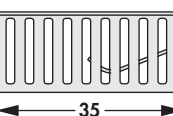
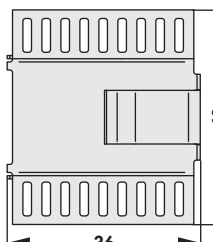
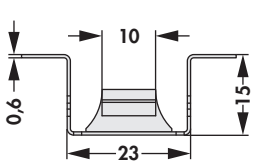
<p>art. no.</p> <p>FK 277 MI 247 O</p>		<p>18,9 K/W</p> 		
<p>art. no.</p> <p>FK 277 MI 247 H</p>		<p>19,2 K/W</p> 		
<p>art. no.</p> <p>FK 277 MI 247 V</p>		<p>18,4 K/W</p> 		
<p>art. no.</p> <p>FK 278 MI 247 O</p>		<p>18,6 K/W</p> 		
<p>art. no.</p> <p>FK 278 MI 247 H</p>		<p>18,9 K/W</p> 		
<p>art. no.</p> <p>FK 278 MI 247 V</p>		<p>18,1 K/W</p> 		
<p>material:</p>		<p>copper (Cu)</p>		
<p>surface:</p>		<p>solderable surface</p>		
<p>material thickness:</p>		<p>0.6 mm</p>		

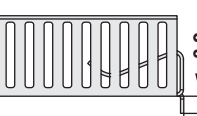
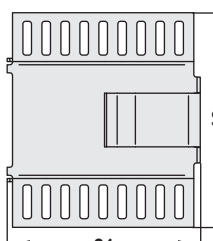
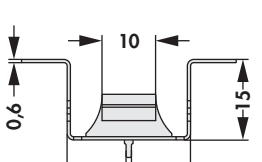

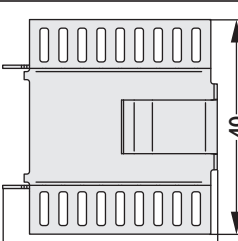
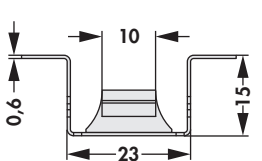

art. no. FK 279 MI 247 O		18,3 K/W 		
art. no. FK 279 MI 247 H		18,6 K/W 		
art. no. FK 279 MI 247 V		17,8 K/W 		
art. no. FK 280 MI 247 O		18,2 K/W 		
art. no. FK 280 MI 247 H		18,5 K/W 		
art. no. FK 280 MI 247 V		17,7 K/W 		
material:		copper (Cu)		
surface:		solderable surface		
material thickness:		0.6 mm		

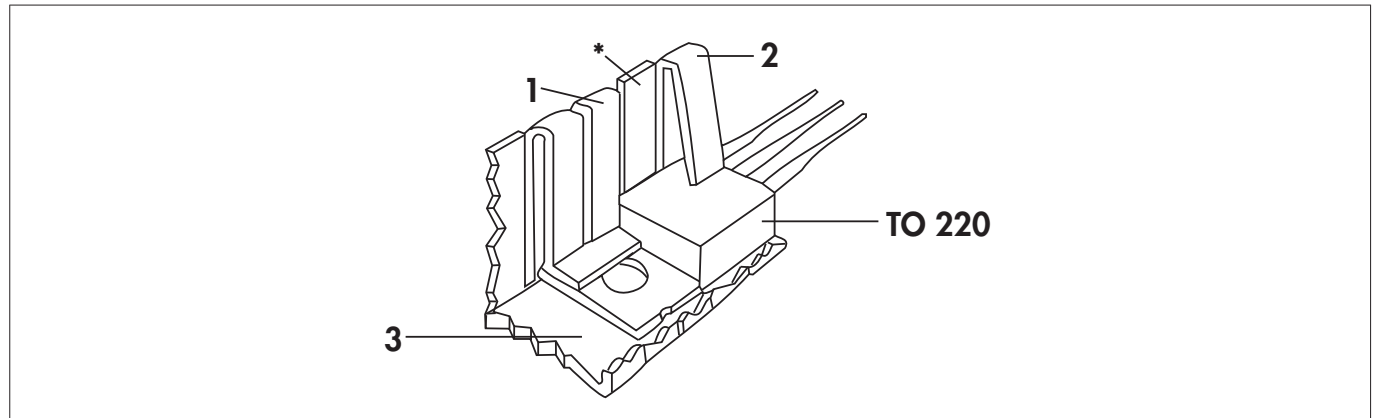

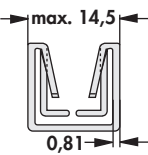
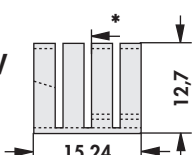
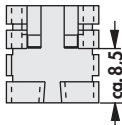

<p>art. no.</p> <p>FK 281 MI 247 O</p>		<p>17,9 K/W</p> 		
<p>art. no.</p> <p>FK 281 MI 247 H</p>		<p>18,2 K/W</p> 		
<p>art. no.</p> <p>FK 281 MI 247 V</p>		<p>17,4 K/W</p> 		
<p>art. no.</p> <p>FK 282 MI 247 O</p>		<p>17,6 K/W</p> 		
<p>art. no.</p> <p>FK 282 MI 247 H</p>		<p>17,9 K/W</p> 		
<p>art. no.</p> <p>FK 282 MI 247 V</p>		<p>17,1 K/W</p> 		
<p>material:</p>		<p>copper (Cu)</p>		
<p>surface:</p>		<p>solderable surface</p>		
<p>material thickness:</p>		<p>0.6 mm</p>		

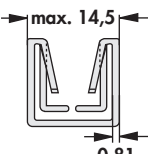
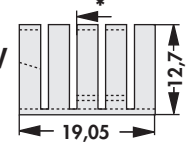
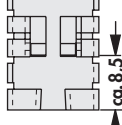
Attachable heatsinks

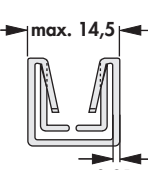
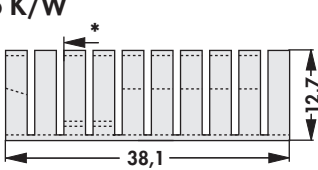
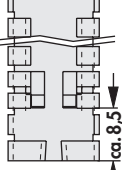

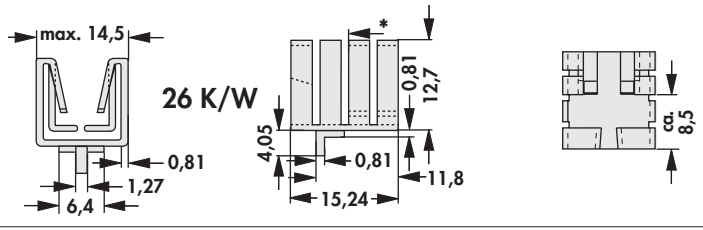

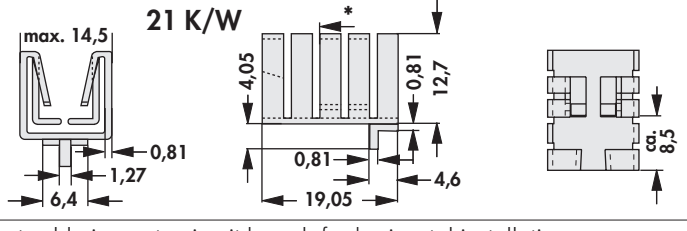

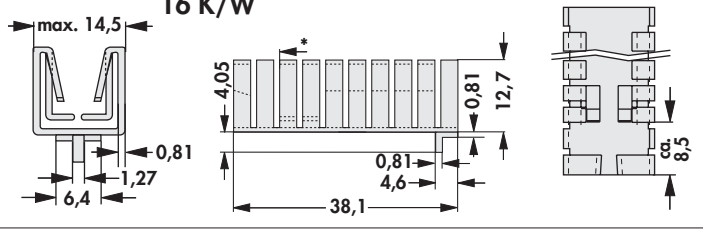

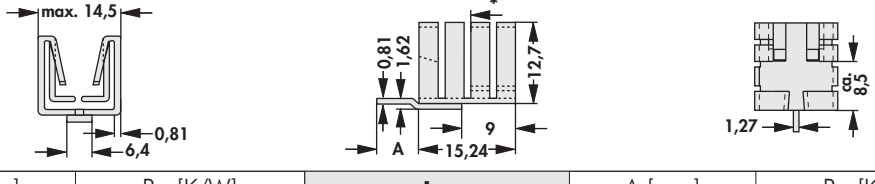

- narrow version with better thermal resistance
- max. 14.5 mm wide
- 3 different lengths for varied dissipation power
- takes less space than any other attachable heatsink
- simple assembly by pushing the heatsink onto the TO 220 housing
- the cooling fingers form spring clamps **(1+2)**, which pushes the TO 220 and its mounting flange onto the heatsink **(3)**
- optimum heat transfer due to the constant pressure on the entire contact surface of the TO 220 cases
- effective heat emission with horizontal and vertical mounting
- * = touch in edge of transistor

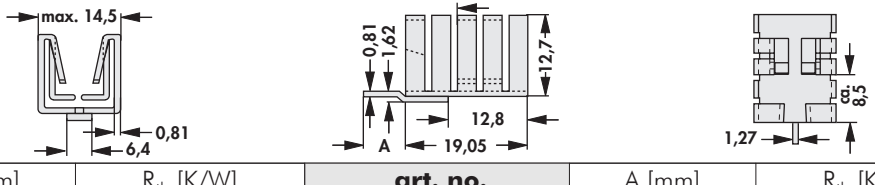
art. no.				
FK 242 SA 220 O	without soldering lug	26 K/W max. 14,5 0,81 15,24 12,7		ca. 8,5
art. no.				
FK 237 SA 220 O	without soldering lug	21 K/W max. 14,5 0,81 19,05 12,7		ca. 8,5
art. no.				
FK 240 SA 220 O	without soldering lug	16 K/W max. 14,5 0,81 38,1 12,7		ca. 8,5
material:	aluminium			
surface:	black anodised, solder pins tin plated			

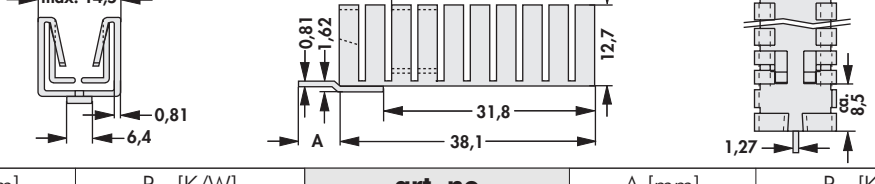
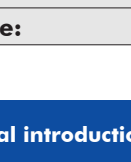
art. no.		
FK 242 SA 220 H	with tinned soldering lug for direct soldering onto circuit board, for horizontal installation	
art. no.		
FK 237 SA 220 H	with tinned soldering lug for direct soldering onto circuit board, for horizontal installation	
art. no.		
FK 240 SA 220 H	with tinned soldering lug for direct soldering onto circuit board, for horizontal installation	
material:	aluminium	
surface:	black anodised, solder pins tin plated	

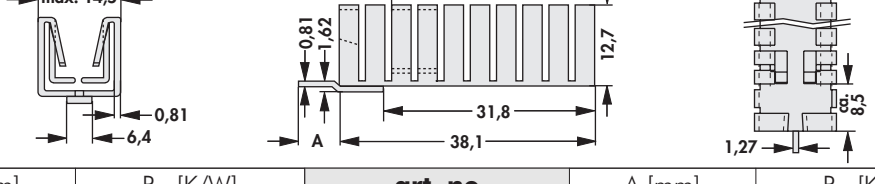
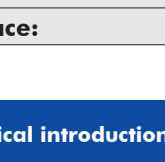
– with tinned soldering lug for direct soldering onto circuit board, for vertical installation

	
art. no.	A [mm] R_{th} [K/W]
FK 242 SA 220 V	6.35 26
	
art. no.	A [mm] R_{th} [K/W]
FK 242 SA 220 VL	9.53 26
	
art. no.	A [mm] R_{th} [K/W]
FK 237 SA 220 V	6.35 21
	
art. no.	A [mm] R_{th} [K/W]
FK 237 SA 220 VL	9.53 21
	
art. no.	A [mm] R_{th} [K/W]
FK 240 SA 220 V	6.35 16
	
art. no.	A [mm] R_{th} [K/W]
FK 240 SA 220 VL	9.53 16
material:	aluminium
surface:	black anodised, solder pins tin plated

Attachable heatsinks for TO 220 with a bottom plate of 0.5 mm

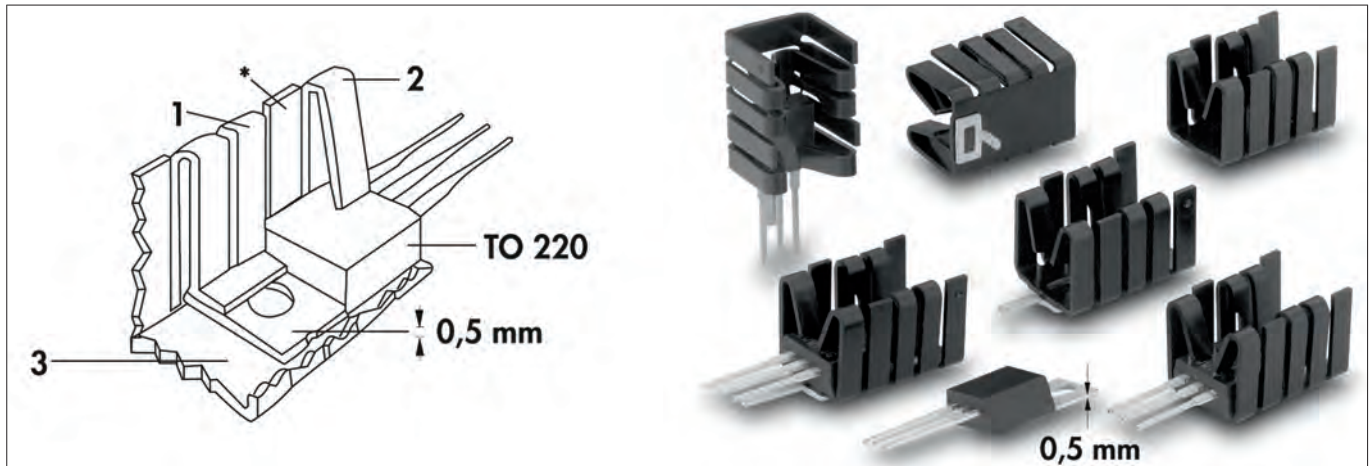



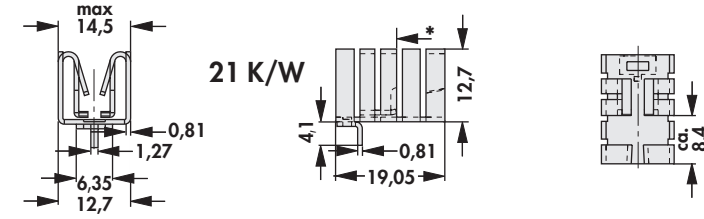

- narrow version with better thermal resistance
- max. 14.5 mm wide
- takes less space than any other attachable heatsink
- simple assembly by pushing the heatsink onto the TO 220 housing
- the cooling fingers form spring clamps **(1+2)**, which pushes the TO 220 and its mounting flange onto the heatsink **(3)**
- optimum heat transfer due to the constant pressure on the entire contact surface of the TO 220 cases
- effective heat emission with horizontal and vertical mounting
- * = touch in edge of transistor

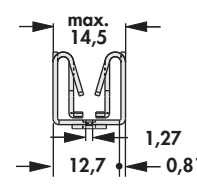
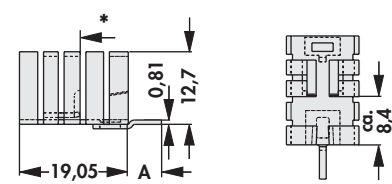
art. no.		 <p>max 14,5 21 K/W 0,81 1,27 6,35 12,7 12,7 4,1 0,81 19,05 ca. 8,4</p>
FK 252 SA 220 H	with tinned soldering lug for direct soldering onto circuit board, for horizontal installation	
material:	aluminium	
surface:	black anodised	

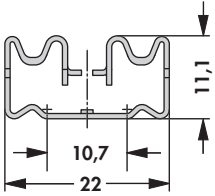
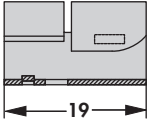
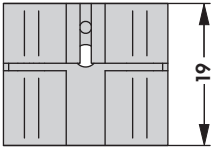
- with tinned soldering lug for direct soldering onto circuit board, for vertical installation

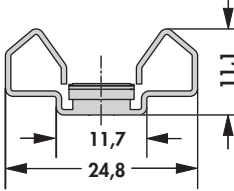
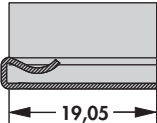
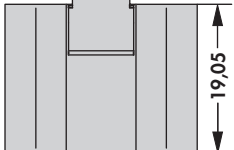
	 <p>max. 14,5 12,7 0,81 1,27</p>	 <p>* 0,81 12,7 19,05 A ca. 8,4</p>			
art. no.	A [mm]	R_{th} [K/W]	art. no.	A [mm]	R_{th} [K/W]
FK 252 SA 220 V	6.35	21	FK 252 SA 220 VL	9.53	21
material:	aluminium				
surface:	black anodised				

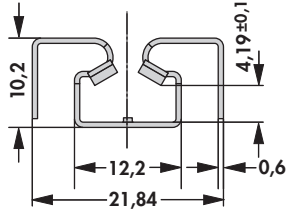
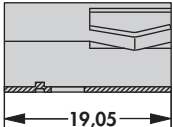
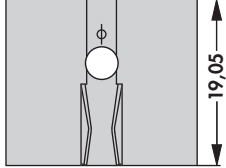
	  	
<p>art. no.</p>	<p>R_{th} [K/W]</p>	<p>ϕ</p>
<p>FK 253</p>	<p>23.7</p>	<p>TO 220</p>
	  	
<p>art. no.</p>	<p>R_{th} [K/W]</p>	<p>ϕ</p>
<p>FK 255</p>	<p>16.8</p>	<p>TO 220</p>
	  	
<p>art. no.</p>	<p>R_{th} [K/W]</p>	<p>ϕ</p>
<p>FK 257</p>	<p>21.2</p>	<p>TO 220</p>
<p>material:</p>	<p>aluminium</p>	
<p>surface:</p>	<p>black anodised</p>	

A

Small heatsinks

B

C

D

E

F

G

H











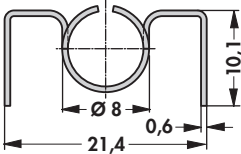

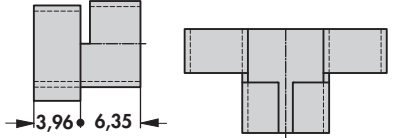
I

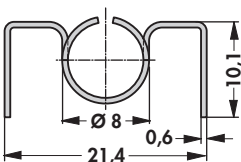

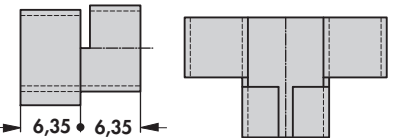
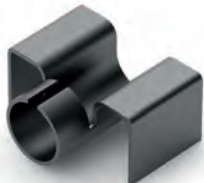
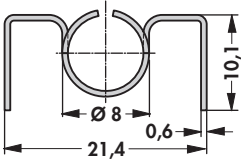

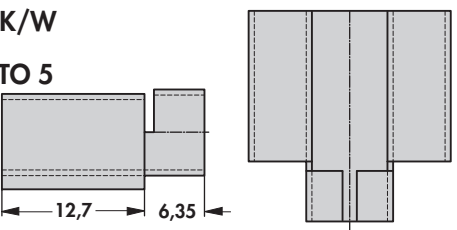

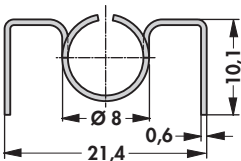

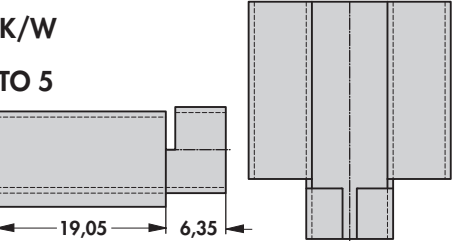



K

L

M

N

art. no. KK 1 3,96		 <p>40 K/W  TO 5</p> 	
art. no. KK 1 6,35		 <p>38 K/W  TO 5</p> 	
art. no. KK 1 12,7		 <p>35 K/W  TO 5</p> 	
art. no. KK 1 19,05		 <p>31 K/W  TO 5</p> 	
material: surface:		aluminium black anodised	

<p>art. no.</p> <p>KF 5/5</p>		 <p>57 K/W  TO 5</p>	
<p>art. no.</p> <p>KF 5/10</p>		 <p>46 K/W  TO 5</p>	
<p>art. no.</p> <p>KF 5/15</p>		 <p>40 K/W  TO 5</p>	
<p>material:</p>		<p>brass</p>	
<p>surface:</p>		<p>blackened</p>	
<p>art. no.</p> <p>KK 562 GS</p>	 <p>T = gap; F = spring loaded</p>	 <p>60 K/W  TO 5</p>	
<p>material:</p>		<p>special bronze CuSn 15</p>	
<p>material thickness:</p>		<p>0.3 mm</p>	
<p>surface:</p>		<p>blackened</p>	

A

Small heatsinks

B

C

D

E

F

G

H











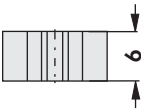

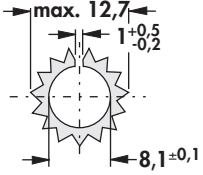

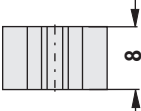

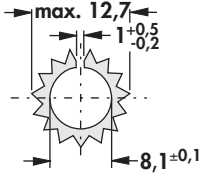

I

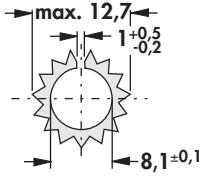
K

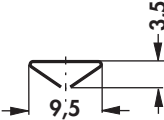
L

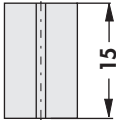
M

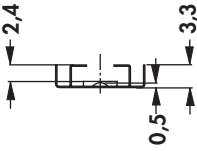
N

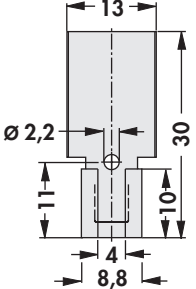





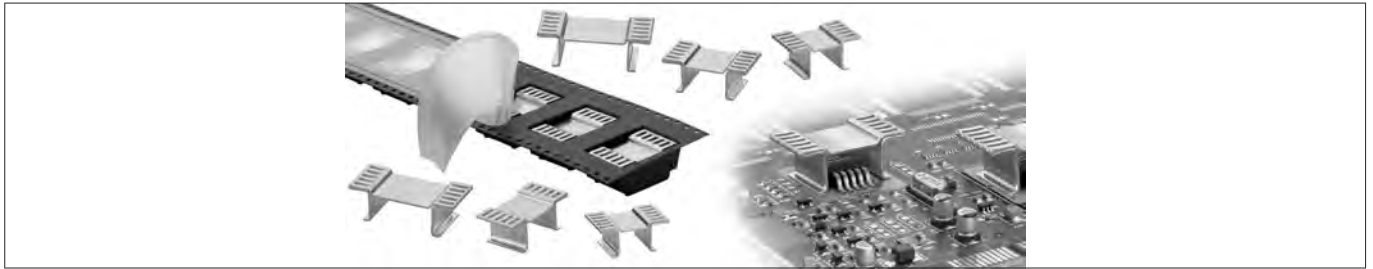

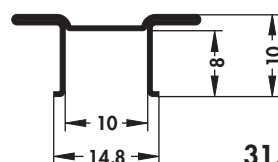
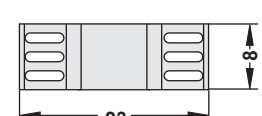

art. no. SKK 56			63 K/W  TO 5	
art. no. SKK 58			55 K/W  TO 5	
art. no. SKK 510			44 K/W  TO 5	
material:		aluminium		
surface:		etched (other surfaces on request)		
art. no. KK 92			80 K/W  TO 126 SOT 32 SOT 82	
art. no. KK 32			60 K/W  TO 126 SOT 32 SOT 82	
material:		special bronze CuSn 6		
surface:		blackened		

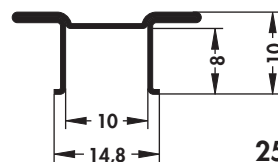
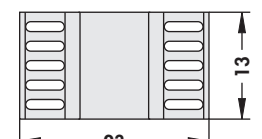

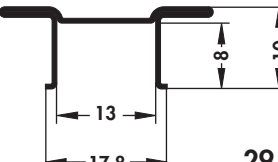
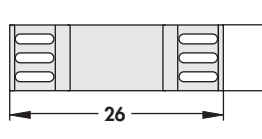
Copper heatsinks for D PAK and others

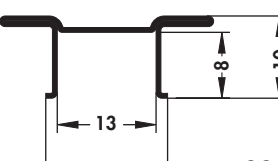
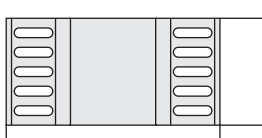

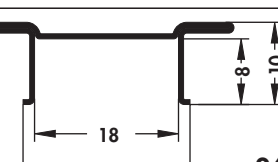
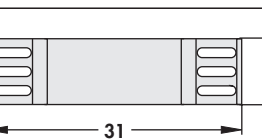
- copper heatsinks with excellent heat conductivity
- direct mounting on printed circuit through solderable surface
- especially suitable for SMD components of type D PAK (TO 252), D² PAK (TO 263), D³ PAK (TO 268), SOT 669 LF PAK, SO IC-8 FL MP, Power SO-8, Power SO-10, Power SO-20, Power SO-36, SO-14, SO-16, SOT 223 etc
- available standard packing: bulk parts or reel
- special packing like magazine, tray etc. on request; - special versions according to customers specifications
- **tape width:** 44 mm, **reel diameter:** 330 mm, **quantity:** FK 244 08 = 450, FK 244 13 = 200

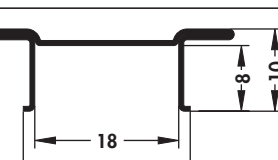
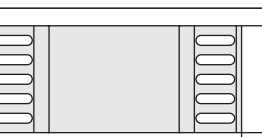
art. no. FK 244 08 D PAK ... weight: 2g		 31,5 K/W	
art. no. FK 244 13 D PAK ... weight: 3.3g		 25 K/W	
art. no. FK 244 08 D2 PAK ... weight: 2.2g		 29,3 K/W	
art. no. FK 244 13 D2 PAK ... weight: 3.6g		 22,8 K/W	
art. no. FK 244 08 D3 PAK ... weight: 2.5g		 26 K/W	
art. no. FK 244 13 D3 PAK ... weight: 3.9g		 19,5 K/W	
please indicate: ... packing (optional) TR = tape and reel			
surface:	solderable surface		
material:	copper (Cu)		
material thickness:	0.6 mm		



Copper heatsinks for D PAK and others

- **tape width:** 24 mm, **reel diameter:** 330 mm, **quantity:** FK 250 06 = 450, FK 250 08 = 450, FK 250 10 = 350
- **tape width:** 24 mm, **reel diameter:** 330 mm, **quantity:** FK 251 06 = 450, FK 251 08 = 350, FK 251 10 = 250

art. no.			37 K/W	
FK 250 06 LF PAK ... weight: 1g				
art. no.			34,8 K/W	
FK 250 08 LF PAK ... weight: 1.1g				
art. no.			28,8 K/W	
FK 250 10 LF PAK ... weight: 1.2g				
art. no.			32 K/W	
FK 251 06 LF PAK ... weight: 1.3g				
art. no.			29,8 K/W	
FK 251 08 LF PAK ... weight: 1.4g				
art. no.			24 K/W	
FK 251 10 LF PAK ... weight: 1.5g				
please indicate:	... packing (optional) TR = tape and reel			
surface:	solderable surface			
material:	copper (Cu)			
material thickness:	0.6 mm			

art. no.			11 K/W	
FK 256 ... weight: 5.7g				
please indicate:	... packing (optional) TR = tape and reel			
surface:	solderable surface			
material:	copper (Cu)			
material thickness:	0.6 mm			

A

Copper heatsinks for D PAK and others

B

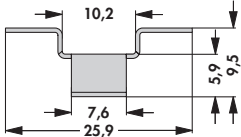
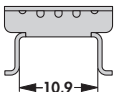
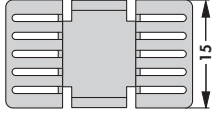
art. no.			15 K/W 	
FK 283 weight: 2.3g				
surface:	solderable surface			
material:	copper (Cu)			
material thickness:	0.6 mm			

C

D

E

F

G

H

I

K

L

M

N



Segment cooling aggregates

- modular assembly consisting of different circle- and length segments
- electrical and thermal insulation of the single cooling segment sections
- standard drilling patterns TO 3 and pressfit
- segment profile also sold by the meter
- other fan types and fan voltages upon request



Miniature cooling aggregates

- compact construction for dissipating high power losses on smallest installation space
- heatsink geometries and fixed length optimal adjusted to the fan being used
- homogeneous heat dissipation
- mounting of the semi-conductor by means of sliding nut channels or specific snap-to-retaining springs for transistors



Hollow fin cooling aggregates

- flow-optimized hollow fin geometry
- precise milled flat semiconductor mounting surface, single- and double-sided
- laminar airflow and noise reduction by means of harmonized chamber systems
- additional treatments, modifications and designs according to customers specifications

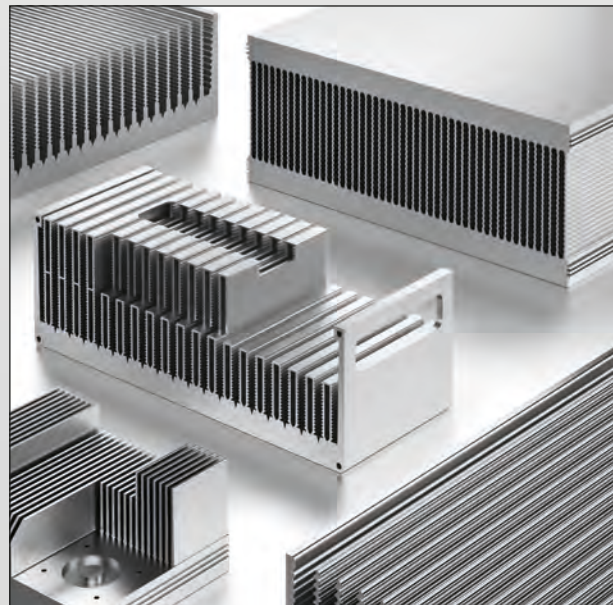

High performance heatsinks

- exclusive for forced convection
- for radial- and tangential fans
- flow-optimized design, best heat dissipation by means of especially thick bottom plates
- precise milled flat semiconductor mounting surfaces
- mechanical treatments, special designs and surface coating for your application

Semiconductor cooling package, consisting of 4 heatsinks LA 1 - 2 A (segment C), 1 heatsink LA 1 - 8 A (segment D), 8 heatsinks LA 1 - 1 A (segment E) and 2 heatsinks LA 1 - 4 A (segment F).
Total dissipation 1280 W.

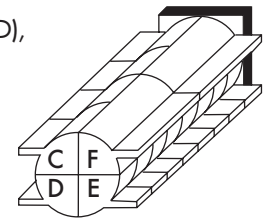

How to tick off?

1. Tick on the left hand side the circles corresponding to an eight element long package, and also at the end of each row of the segments C, D, E and F to define the length.
2. For segment C: 4 marks for four double length elements, insulated from each other. This indicates 4 units LA 1 - 2.
3. For segment D: 1 mark for one single length of heatsink, 290.5 mm long. This indicates 1 unit LA 1 - 8.
4. For segment E: 8 marks for 8 elements of the standard length (35 mm) each insulated from the other. This indicates 8 units LA 1 - 1.
5. For segment F: 2 marks for each two heatsinks of 144.5 mm length, each insulated from the other. This indicates 2 units LA 1 - 4.
6. For each segment the profile types, either A or B, must be indicated for aggregate LA 1.
7. In the rectangle corresponding to the heatsink elements, the pin layouts for the transistor should also be indicated.
8. In the order form please indicate whether the cooling-aggregate is to be supplied with a fan and whether this is equipped with a protection-grid, or if it is to be supplied without a fan.

Upon request, it is possible to supply fans for special voltages and higher temperatures.

LA 1 **LA 2**

date: _____

pieces p. order: _____

company: _____

name/dept.: _____

town: _____

street: _____

signature: _____

with fan 230 Volt Volt
 protection grid voltage: ~ =
 without fan

Order example

length units: mm	segment: C	segment: D	segment: E	segment: F
35.0 <input checked="" type="checkbox"/> 1 <input type="checkbox"/>	<input checked="" type="checkbox"/> Typ. A O B TO-3 holder TO-3 hole pressfit hole <input type="checkbox"/> <input type="checkbox"/> <input type="checkbox"/> <input type="checkbox"/>	<input checked="" type="checkbox"/> Typ. A O B TO-3 holder TO-3 hole pressfit hole <input type="checkbox"/> <input type="checkbox"/> <input type="checkbox"/> <input type="checkbox"/>	<input checked="" type="checkbox"/> Typ. A O B TO-3 holder TO-3 hole pressfit hole <input type="checkbox"/> <input type="checkbox"/> <input type="checkbox"/> <input type="checkbox"/>	<input checked="" type="checkbox"/> Typ. A O B TO-3 holder TO-3 hole pressfit hole <input type="checkbox"/> <input type="checkbox"/> <input type="checkbox"/> <input type="checkbox"/>
71.5 <input type="checkbox"/> 2 <input type="checkbox"/>	<input type="checkbox"/> Typ. A O B TO-3 holder TO-3 hole pressfit hole <input type="checkbox"/> <input type="checkbox"/> <input type="checkbox"/> <input type="checkbox"/>	<input type="checkbox"/> Typ. A O B TO-3 holder TO-3 hole pressfit hole <input type="checkbox"/> <input type="checkbox"/> <input type="checkbox"/> <input type="checkbox"/>	<input checked="" type="checkbox"/> Typ. A O B TO-3 holder TO-3 hole pressfit hole <input type="checkbox"/> <input type="checkbox"/> <input type="checkbox"/> <input type="checkbox"/>	<input type="checkbox"/> Typ. A O B TO-3 holder TO-3 hole pressfit hole <input type="checkbox"/> <input type="checkbox"/> <input type="checkbox"/> <input type="checkbox"/>
108.0 <input type="checkbox"/> 3 <input type="checkbox"/>	<input type="checkbox"/> Typ. A O B TO-3 holder TO-3 hole pressfit hole <input type="checkbox"/> <input type="checkbox"/> <input type="checkbox"/> <input type="checkbox"/>	<input type="checkbox"/> Typ. A O B TO-3 holder TO-3 hole pressfit hole <input type="checkbox"/> <input type="checkbox"/> <input type="checkbox"/> <input type="checkbox"/>	<input type="checkbox"/> Typ. A O B TO-3 holder TO-3 hole pressfit hole <input type="checkbox"/> <input type="checkbox"/> <input type="checkbox"/> <input type="checkbox"/>	<input type="checkbox"/> Typ. A O B TO-3 holder TO-3 hole pressfit hole <input type="checkbox"/> <input type="checkbox"/> <input type="checkbox"/> <input type="checkbox"/>
144.5 <input type="checkbox"/> 4 <input type="checkbox"/>	<input type="checkbox"/> Typ. A O B TO-3 holder TO-3 hole pressfit hole <input type="checkbox"/> <input type="checkbox"/> <input type="checkbox"/> <input type="checkbox"/>	<input type="checkbox"/> Typ. A O B TO-3 holder TO-3 hole pressfit hole <input type="checkbox"/> <input type="checkbox"/> <input type="checkbox"/> <input type="checkbox"/>	<input checked="" type="checkbox"/> Typ. A O B TO-3 holder TO-3 hole pressfit hole <input type="checkbox"/> <input type="checkbox"/> <input type="checkbox"/> <input type="checkbox"/>	<input checked="" type="checkbox"/> Typ. A O B TO-3 holder TO-3 hole pressfit hole <input type="checkbox"/> <input type="checkbox"/> <input type="checkbox"/> <input type="checkbox"/>
181.0 <input type="checkbox"/> 5 <input type="checkbox"/>	<input type="checkbox"/> Typ. A O B TO-3 holder TO-3 hole pressfit hole <input type="checkbox"/> <input type="checkbox"/> <input type="checkbox"/> <input type="checkbox"/>	<input type="checkbox"/> Typ. A O B TO-3 holder TO-3 hole pressfit hole <input type="checkbox"/> <input type="checkbox"/> <input type="checkbox"/> <input type="checkbox"/>	<input checked="" type="checkbox"/> Typ. A O B TO-3 holder TO-3 hole pressfit hole <input type="checkbox"/> <input type="checkbox"/> <input type="checkbox"/> <input type="checkbox"/>	<input type="checkbox"/> Typ. A O B TO-3 holder TO-3 hole pressfit hole <input type="checkbox"/> <input type="checkbox"/> <input type="checkbox"/> <input type="checkbox"/>
217.5 <input type="checkbox"/> 6 <input type="checkbox"/>	<input checked="" type="checkbox"/> Typ. A O B TO-3 holder TO-3 hole pressfit hole <input type="checkbox"/> <input type="checkbox"/> <input type="checkbox"/> <input type="checkbox"/>	<input type="checkbox"/> Typ. A O B TO-3 holder TO-3 hole pressfit hole <input type="checkbox"/> <input type="checkbox"/> <input type="checkbox"/> <input type="checkbox"/>	<input checked="" type="checkbox"/> Typ. A O B TO-3 holder TO-3 hole pressfit hole <input type="checkbox"/> <input type="checkbox"/> <input type="checkbox"/> <input type="checkbox"/>	<input type="checkbox"/> Typ. A O B TO-3 holder TO-3 hole pressfit hole <input type="checkbox"/> <input type="checkbox"/> <input type="checkbox"/> <input type="checkbox"/>
254.0 <input type="checkbox"/> 7 <input type="checkbox"/>	<input type="checkbox"/> Typ. A O B TO-3 holder TO-3 hole pressfit hole <input type="checkbox"/> <input type="checkbox"/> <input type="checkbox"/> <input type="checkbox"/>	<input type="checkbox"/> Typ. A O B TO-3 holder TO-3 hole pressfit hole <input type="checkbox"/> <input type="checkbox"/> <input type="checkbox"/> <input type="checkbox"/>	<input checked="" type="checkbox"/> Typ. A O B TO-3 holder TO-3 hole pressfit hole <input type="checkbox"/> <input type="checkbox"/> <input type="checkbox"/> <input type="checkbox"/>	<input type="checkbox"/> Typ. A O B TO-3 holder TO-3 hole pressfit hole <input type="checkbox"/> <input type="checkbox"/> <input type="checkbox"/> <input type="checkbox"/>
290.5 <input checked="" type="checkbox"/> 8 <input type="checkbox"/>	<input type="checkbox"/> Typ. A O B TO-3 holder TO-3 hole pressfit hole <input type="checkbox"/> <input type="checkbox"/> <input type="checkbox"/> <input type="checkbox"/>	<input checked="" type="checkbox"/> Typ. A O B TO-3 holder TO-3 hole pressfit hole <input type="checkbox"/> <input type="checkbox"/> <input type="checkbox"/> <input type="checkbox"/>	<input checked="" type="checkbox"/> Typ. A O B TO-3 holder TO-3 hole pressfit hole <input type="checkbox"/> <input type="checkbox"/> <input type="checkbox"/> <input type="checkbox"/>	<input checked="" type="checkbox"/> Typ. A O B TO-3 holder TO-3 hole pressfit hole <input type="checkbox"/> <input type="checkbox"/> <input type="checkbox"/> <input type="checkbox"/>
327.0 <input type="checkbox"/> 9 <input type="checkbox"/>	<input type="checkbox"/> Typ. A O B TO-3 holder TO-3 hole pressfit hole <input type="checkbox"/> <input type="checkbox"/> <input type="checkbox"/> <input type="checkbox"/>	<input type="checkbox"/> Typ. A O B TO-3 holder TO-3 hole pressfit hole <input type="checkbox"/> <input type="checkbox"/> <input type="checkbox"/> <input type="checkbox"/>	<input type="checkbox"/> Typ. A O B TO-3 holder TO-3 hole pressfit hole <input type="checkbox"/> <input type="checkbox"/> <input type="checkbox"/> <input type="checkbox"/>	<input type="checkbox"/> Typ. A O B TO-3 holder TO-3 hole pressfit hole <input type="checkbox"/> <input type="checkbox"/> <input type="checkbox"/> <input type="checkbox"/>
363.5 <input type="checkbox"/> 10 <input type="checkbox"/>	<input type="checkbox"/> Typ. A O B TO-3 holder TO-3 hole pressfit hole <input type="checkbox"/> <input type="checkbox"/> <input type="checkbox"/> <input type="checkbox"/>	<input type="checkbox"/> Typ. A O B TO-3 holder TO-3 hole pressfit hole <input type="checkbox"/> <input type="checkbox"/> <input type="checkbox"/> <input type="checkbox"/>	<input type="checkbox"/> Typ. A O B TO-3 holder TO-3 hole pressfit hole <input type="checkbox"/> <input type="checkbox"/> <input type="checkbox"/> <input type="checkbox"/>	<input type="checkbox"/> Typ. A O B TO-3 holder TO-3 hole pressfit hole <input type="checkbox"/> <input type="checkbox"/> <input type="checkbox"/> <input type="checkbox"/>

C D E F

cable connection

C
F

D
E

The segment-line C-D-E-F is shown against air-escape orifice, thus on the other side of the axial fan. From this view also tick off cable terminal with axial fan.

Please check off here total length of the cooling aggregate.

A

LA 1 ○

LA 2 ○

B

date: _____

pieces p. order: _____

company: _____

C

name/dept.: _____

town: _____

street: _____

D

signature: _____

- with fan 230 Volt Volt
 protection grid voltage:
 without fan ~ =

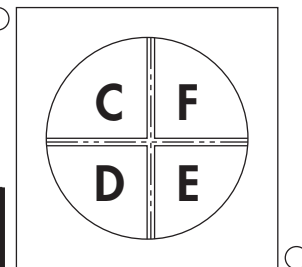

cable connection

E

length units:
mm

segment:

segment:

segment:

segment:

35.0 1
 Typ. A ○ B ○
 TO-3 holder ○
 TO-3 hole ○
 pressfit hole ○

 Typ. A ○ B ○
 TO-3 holder ○
 TO-3 hole ○
 pressfit hole ○

 Typ. A ○ B ○
 TO-3 holder ○
 TO-3 hole ○
 pressfit hole ○

 Typ. A ○ B ○
 TO-3 holder ○
 TO-3 hole ○
 pressfit hole ○
71.5 2
 Typ. A ○ B ○
 TO-3 holder ○
 TO-3 hole ○
 pressfit hole ○

 Typ. A ○ B ○
 TO-3 holder ○
 TO-3 hole ○
 pressfit hole ○

 Typ. A ○ B ○
 TO-3 holder ○
 TO-3 hole ○
 pressfit hole ○

 Typ. A ○ B ○
 TO-3 holder ○
 TO-3 hole ○
 pressfit hole ○
108.0 3
 Typ. A ○ B ○
 TO-3 holder ○
 TO-3 hole ○
 pressfit hole ○

 Typ. A ○ B ○
 TO-3 Fassung ○
 TO-3 Lochung ○
 Preßfit-Bohrg. ○

 Typ. A ○ B ○
 TO-3 holder ○
 TO-3 hole ○
 pressfit hole ○

 Typ. A ○ B ○
 TO-3 holder ○
 TO-3 hole ○
 pressfit hole ○
144.5 4
 Typ. A ○ B ○
 TO-3 holder ○
 TO-3 hole ○
 pressfit hole ○

 Typ. A ○ B ○
 TO-3 holder ○
 TO-3 hole ○
 pressfit hole ○

 Typ. A ○ B ○
 TO-3 holder ○
 TO-3 hole ○
 pressfit hole ○

 Typ. A ○ B ○
 TO-3 holder ○
 TO-3 hole ○
 pressfit hole ○
181.0 5
 Typ. A ○ B ○
 TO-3 holder ○
 TO-3 hole ○
 pressfit hole ○

 Typ. A ○ B ○
 TO-3 holder ○
 TO-3 hole ○
 pressfit hole ○

 Typ. A ○ B ○
 TO-3 holder ○
 TO-3 hole ○
 pressfit hole ○

 Typ. A ○ B ○
 TO-3 holder ○
 TO-3 hole ○
 pressfit hole ○
217.5 6
 Typ. A ○ B ○
 TO-3 holder ○
 TO-3 hole ○
 pressfit hole ○

 Typ. A ○ B ○
 TO-3 holder ○
 TO-3 hole ○
 pressfit hole ○

 Typ. A ○ B ○
 TO-3 holder ○
 TO-3 hole ○
 pressfit hole ○

 Typ. A ○ B ○
 TO-3 holder ○
 TO-3 hole ○
 pressfit hole ○
254.0 7
 Typ. A ○ B ○
 TO-3 holder ○
 TO-3 hole ○
 pressfit hole ○

 Typ. A ○ B ○
 TO-3 holder ○
 TO-3 hole ○
 pressfit hole ○

 Typ. A ○ B ○
 TO-3 holder ○
 TO-3 hole ○
 pressfit hole ○

 Typ. A ○ B ○
 TO-3 holder ○
 TO-3 hole ○
 pressfit hole ○
290.5 8
 Typ. A ○ B ○
 TO-3 holder ○
 TO-3 hole ○
 pressfit hole ○

 Typ. A ○ B ○
 TO-3 holder ○
 TO-3 hole ○
 pressfit hole ○

 Typ. A ○ B ○
 TO-3 holder ○
 TO-3 hole ○
 pressfit hole ○

 Typ. A ○ B ○
 TO-3 holder ○
 TO-3 hole ○
 pressfit hole ○
327.0 9
 Typ. A ○ B ○
 TO-3 holder ○
 TO-3 hole ○
 pressfit hole ○

 Typ. A ○ B ○
 TO-3 holder ○
 TO-3 hole ○
 pressfit hole ○

 Typ. A ○ B ○
 TO-3 holder ○
 TO-3 hole ○
 pressfit hole ○

 Typ. A ○ B ○
 TO-3 holder ○
 TO-3 hole ○
 pressfit hole ○
363.5 10
 Typ. A ○ B ○
 TO-3 holder ○
 TO-3 hole ○
 pressfit hole ○

 Typ. A ○ B ○
 TO-3 holder ○
 TO-3 hole ○
 pressfit hole ○

 Typ. A ○ B ○
 TO-3 holder ○
 TO-3 hole ○
 pressfit hole ○

 Typ. A ○ B ○
 TO-3 holder ○
 TO-3 hole ○
 pressfit hole ○

C

D

E

F

Please check off here total length of the cooling aggregate.

The segment-line C-D-E-F is shown against air-escape orifice, thus on the other side of the axial fan. From this view also tick off cable terminal with axial fan.

M

N

D 3

LA 1

LA 2

date: _____

pieces p. order: _____

company: _____

name/dept.: _____

town: _____

street: _____

signature: _____

with fan 230 Volt Volt
 protection grid voltage:
 without fan ~ =

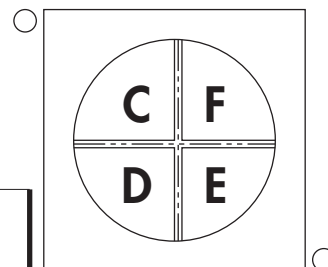

cable connection

length units:
mm

segment:	segment:	segment:	segment:	
<input type="radio"/> Typ. A <input type="radio"/> B <input type="radio"/> TO-3 holder <input type="radio"/> TO-3 hole <input type="radio"/> pressfit hole	<input type="radio"/> Typ. A <input type="radio"/> B <input type="radio"/> TO-3 holder <input type="radio"/> TO-3 hole <input type="radio"/> pressfit hole	<input type="radio"/> Typ. A <input type="radio"/> B <input type="radio"/> TO-3 holder <input type="radio"/> TO-3 hole <input type="radio"/> pressfit hole	<input type="radio"/> Typ. A <input type="radio"/> B <input type="radio"/> TO-3 holder <input type="radio"/> TO-3 hole <input type="radio"/> pressfit hole	
35.0 1				
71.5 2				
108.0 3	<input type="radio"/> Typ. A <input type="radio"/> B <input type="radio"/> TO-3 Fassung <input type="radio"/> TO-3 Lochung <input type="radio"/> Preßfit-Bohrg.			
144.5 4				
181.0 5				
217.5 6				
254.0 7				
290.5 8				
327.0 9				
363.5 10				
	C	D	E	F

The segment-line C-D-E-F is shown against air-escape orifice, thus on the other side of the axial fan. From this view also tick off cable terminal with axial fan.

Please check off here total length of the cooling aggregate.

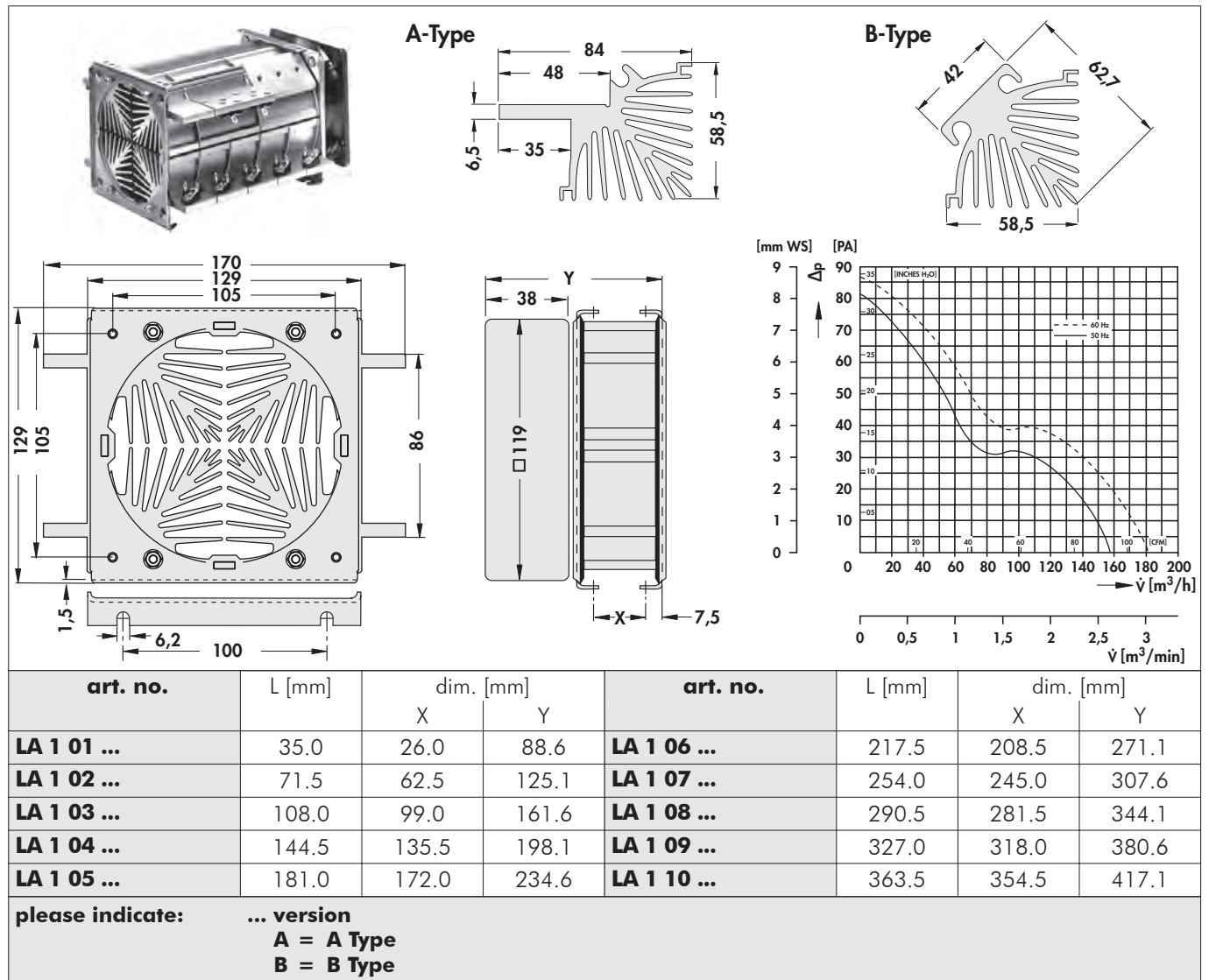

L: unit lengths of the segments incl. insulation; **X:** mounting distance; **Y:** length of the cooling aggregate incl. fan

24 V DC fan on request

In case of order please use order form → D 3.

segments also available in meter length:

art. no. for A-type: LA 1 1000 A; art. no. for B-type: LA 1 1000 B

Other fan types and fan voltages on request.

Technical data of the fans

	... 230
type	ebmpapst 4656N
dimensions	119x119x38 mm
tension	230 V AC
power inout	19 W
max. air volume	160 m ³ /h
temperature range	-40°C... +85°C
noise level	47 dB(A)
speed	2,650 min ⁻¹
weight	550 g
failure rate (L₁₀)	L ₁₀ > 37,500 h (40°C)

Thermal resistance LA 1

The thermal resistance in the following diagrams is given on the base of a total dissipation of 40 Watt per heatsink of the „A“-type. When using „B“-types this value increases by 3 %.

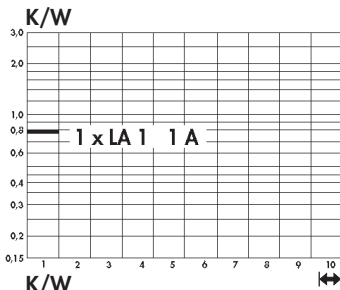

1. Cooling aggregate consisting of 4 heatsinks LA 1 - 1 A.
Total dissipation 160 W.

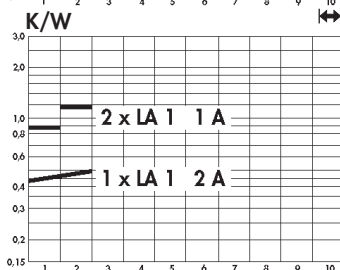

2. Cooling aggregate consisting of 4 heatsinks LA 1 - 1 A and 2 x 1 heatsink LA 1 - 2 A.
Total dissipation 320 W.

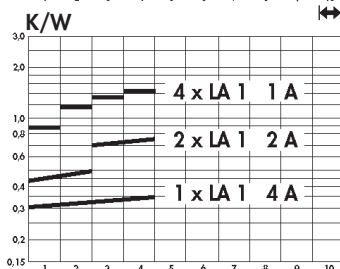

3. Cooling aggregate consisting of 4 heatsinks LA 1 - 1 A, 2 heatsinks LA 1 - 2 A and 2 x 1 heatsink LA 1 - 4 A. Total dissipation 640 W.

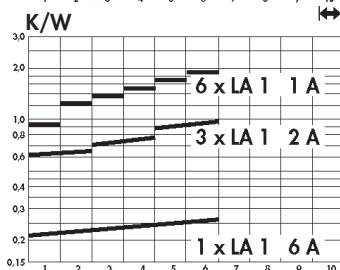

4. Cooling aggregate consisting of 6 heatsinks LA 1 - 1 A, 3 heatsinks LA 1 - 2 A and 2 x 1 heatsink LA 1 - 6 A. Total dissipation 960 W.

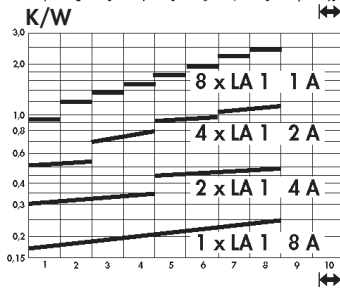

5. Cooling aggregate consisting of 8 heatsinks LA 1 - 1 A, 4 heatsinks LA 1 - 2 A, 2 heatsinks LA 1 - 4 A and 1 heatsink LA 1 - 8 A. Total dissipation 1280 W.

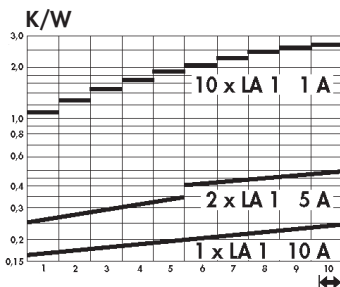

6. Cooling aggregate consisting of 10 heatsinks LA 1 - 1 A, 2 heatsinks LA 1 - 5 A, and 2 x 1 heatsink LA 1 - 10 A. Total dissipation 1600 W.

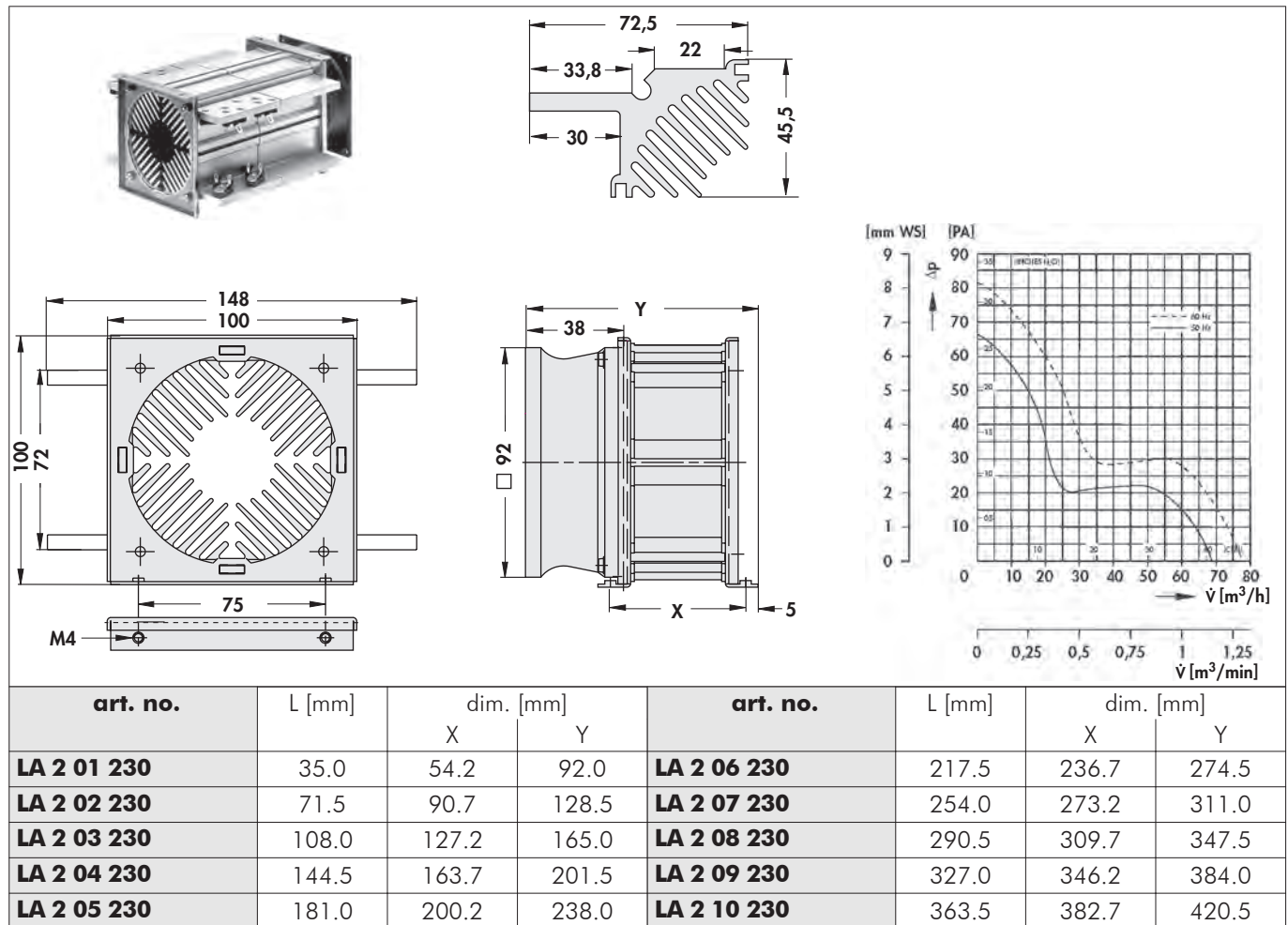

L: unit lengths of the segments incl. insulation; **X:** mounting distance; **Y:** length of the cooling aggregate incl. fan

24 V DC fan on request

In case of order please use order form → D 3.

segments also available in meter length: **art. no. LA 2 1000**

Other fan types and fan voltages on request.

Technical data of the fans

	... 230
type	ebmpapst 3656
dimensions	92x92x38 mm
tension	230 V AC
power inout	12 W
max. air volume	75 m ³ /h
temperature range	-40°C... +75°C
noise level	37 dB(A)
speed	2,700 min ⁻¹
weight	420 g
failure rate (L₁₀)	L ₁₀ > 52,500 h (40°C)

Thermal resistance LA 2

The thermal resistance in the following diagrams is given on the base of a total dissipation of 40 Watt per heatsink of the „A“-type.

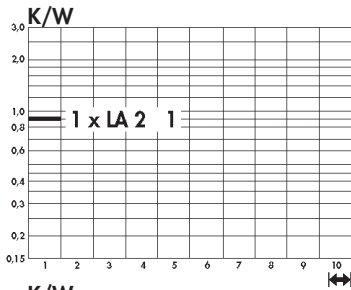

1. Cooling aggregate consisting of 4 heatsinks LA 2 - 1. Total dissipation 160 W maximal.

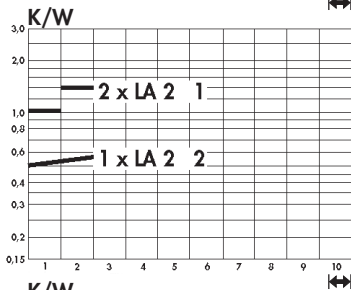

2. Cooling aggregate consisting of 4 heatsinks LA 2 - 1 and 2 x 1 heatsink LA 2 - 2. Total dissipation 320 W.

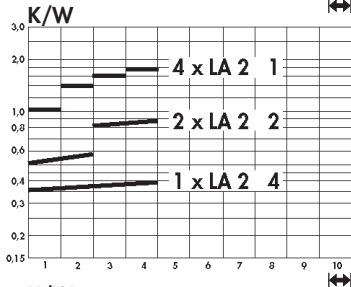

3. Cooling aggregate consisting of 4 heatsinks LA 2 - 1, 2 heatsinks LA 2 - 2 and 2 x 1 heatsink LA 2 - 4. Total dissipation 640 W.

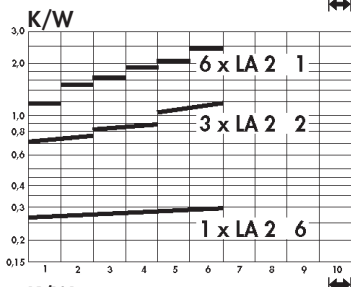

4. Cooling aggregate consisting of 6 heatsinks LA 2 - 1, 3 heatsinks LA 2 - 2 and 2 x 1 heatsink LA 2 - 6. Total dissipation 960 W.

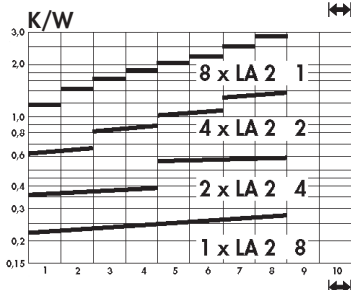

5. Cooling aggregate consisting of 8 heatsinks LA 2 - 1, 4 heatsinks LA 2 - 2, 2 heatsinks LA 2 - 4 and 1 heatsink LA 2 - 8. Total dissipation 1280 W.

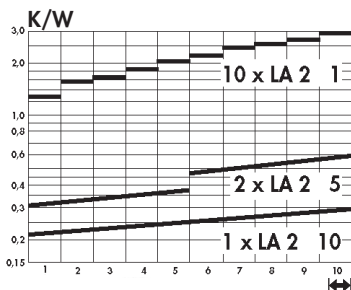

6. Cooling aggregate consisting of 10 heatsinks LA 2 - 1, 2 heatsinks LA 2 - 5, and 2 x 1 heatsink LA 2 - 10. Total dissipation 1600 W.

A

B

C

D

E

F

G

H

I





K

L

M

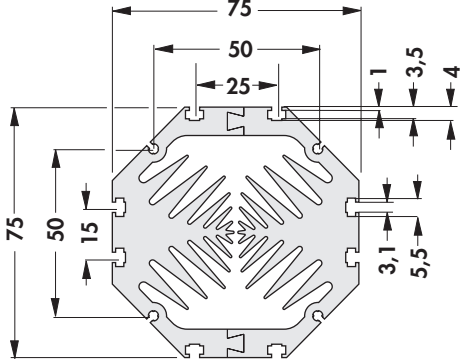
N

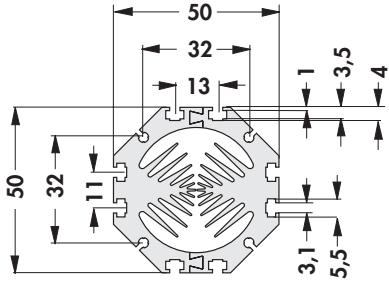
- made for dissipation of high power within a very small space
- fixed length is optimised to the fan
- slide-nut channels for M3 nuts for mounting the transistors and circuit boards
- other fan types and fan voltages on request

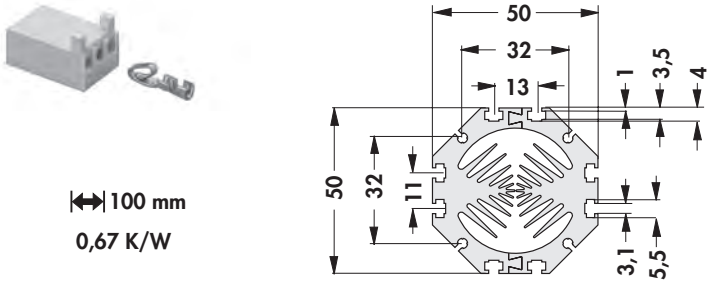

<p>art. no.</p> <p>LAM 1</p>		 <p>140 mm 0,3 K/W</p>
<p>art. no.</p> <p>LAM 2</p>		 <p>100 mm 0,73 K/W</p>
<p>art. no.</p> <p>LAM 2 S</p>		 <p>100 mm 0,67 K/W</p> <p>pre-assembled with Molex case 2695 including alarm output, 3 pins; → B 77; strand length: 70 mm</p>
<p>surface:</p>		<p>natural colour anodised</p>

Technical data of the fans

	LAM 1	LAM 2	LAM 2
type	ebmpapst 612 NHH-118	ebmpapst 412 F	sepa MFB 40 H 12 HA
dimensions	60x60x25 mm	40x40x10 mm	40x40x10 mm
tension	12 V DC	12 V DC	12 V DC
power inout	2.9 W	0.7 W	0.6 W
max. air volume	56 m ³ /h	8 m ³ /h	10.4 m ³ /h
temperature range	-20°C... +70°C	-20°C... +70°C	-40°C... +85°C
noise level	41 dB(A)	22.1 dB(A)	25 dB(A)
speed	6,800 min ⁻¹	5,400 min ⁻¹	min ⁻¹
weight	66 g	17 g	13 g
failure rate (L₁₀)	L ₁₀ > 60,000 h (40°C)	L ₁₀ > 45,000 h (20°C)	L ₁₀ > 40,000 h (40°C)

Miniature cooling aggregates

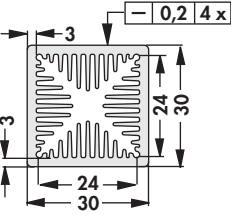
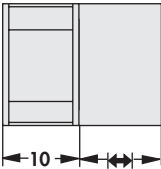
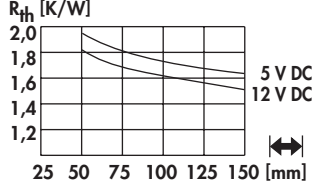

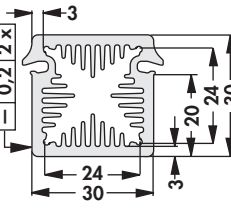
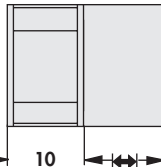
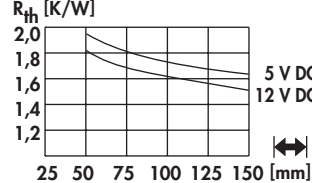

- compact design
- homogeneous heat distribution
- mounting possible on any side
- powerful axial-fan motor
- other lengths, special designs and machinings according to customer's specifications
- other surfaces, fan types and fan voltages upon request

art. no. LAM 3 ...				
art. no. LAM 3 K ...				
LAM 3 K ... with grooves for lock-in retaining spring for transistors THFU → A 165				
please indicate: ... $\left[\begin{array}{c} \text{---} \\ \text{---} \end{array} \right]$ 50 75 100 125 150 mm		... fan type 5 = 5 V DC 12 = 12 V DC		
surface:	natural colour anodised			

Technical data of the fans

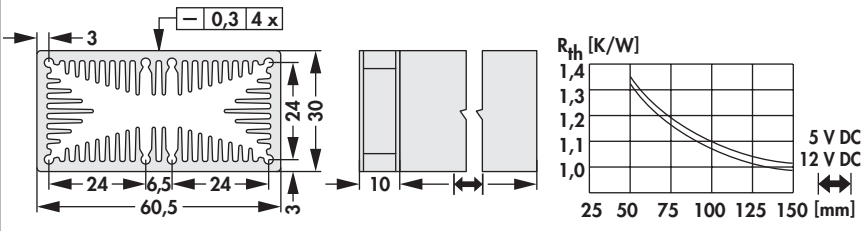
	... 5	... 12
type	Sepa, MFB 30 G 05	Sepa, MFB 30 G 12
dimensions	30x30x10 mm	30x30x10 mm
tension	5 V DC	12 V DC
max. air volume	6.8 m ³ /h	7.7 m ³ /h
cur. consumpt.	120 mA	60 mA
temperature range		-10°C ... +85°C
noise level	25 dB(A)	26 dB(A)
speed	8,500 min ⁻¹	9,100 min ⁻¹
weight	8 g	8 g
failure rate (L₁₀)		

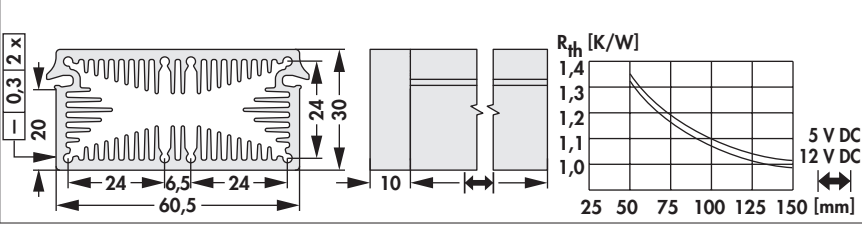

- compact design
- homogeneous heat distribution
- mounting possible on any side
- powerful axial-fan motor
- other lengths, special designs and machinings according to customer's specifications
- other surfaces, fan types and fan voltages upon request

art. no.		
LAM 3 D ...		
art. no.		
LAM 3 D K ...	with grooves for lock-in retaining spring for transistors THFU → A 165	
please indicate:	...  50 75 100 125 150 mm	
	... fan type 5 = 5 V DC 12 = 12 V DC	
surface:	natural colour anodised	

Technical data of the fans

	... 5	... 12
type	Sepa, MFB 30 G 05	Sepa, MFB 30 G 12
dimensions	30x30x10 mm	30x30x10 mm
tension	5 V DC	12 V DC
max. air volume	6.8 m ³ /h	7.7 m ³ /h
cur. consumpt.	120 mA	60 mA
temperature range		-10°C ... +85°C
noise level	25 dB(A)	26 dB(A)
speed	8,500 min ⁻¹	9,100 min ⁻¹
weight	8 g	8 g
failure rate (L₁₀)		

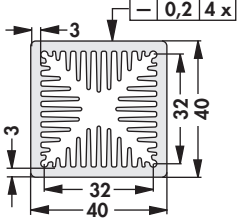
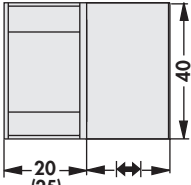
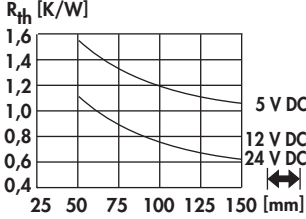

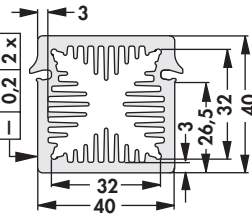
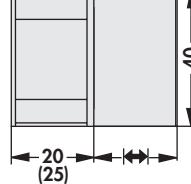
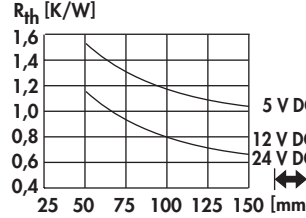
- compact design
- homogeneous heat distribution
- mounting possible on any side
- powerful axial-fan motor
- other lengths, special designs and machinings according to customer's specifications
- other surfaces, fan types and fan voltages upon request

art. no. LAM 4 ...				
art. no. LAM 4 K ...				
with grooves for lock-in retaining spring for transistors THFU → A 165				
please indicate: ... $\left[\text{mm} \right]$ 50 75 100 125 150 mm		... fan type 5 = 5 V DC 12 = 12 V DC 24 = 24 V DC		
surface:		natural colour anodised		

Technical data of the fans

	... 5	... 12	... 24
type	ebmpapst 405	ebmpapst 412 JHH	ebmpapst 414 JHH
dimensions	40x40x20 mm	40x40x25 mm	40x40x25 mm
tension	5 V DC	12 V DC	24 V DC
power inout	0.9 W	3.3 W	3.6 W
max. air volume	10 m ³ /h	24 m ³ /h	24 m ³ /h
temperature range	-20°C... +70°C	-20°C... +60°C	-20°C... +60°C
noise level	18 dB(A)	46 dB(A)	46 dB(A)
speed	6,000 min ⁻¹	13,000 min ⁻¹	13,000 min ⁻¹
weight	27 g	50 g	50 g
failure rate (L₁₀)	L ₁₀ < 50,000 h (40°C) L ₁₀ < 20,000 h (tmax)	L ₁₀ < 57,500 h (40°C) L ₁₀ < 35,000 h (tmax)	L ₁₀ < 57,500 h (40°C) L ₁₀ < 35,000 h (tmax)

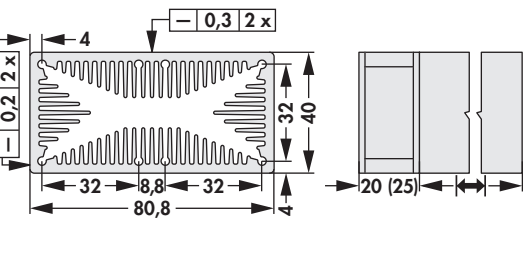
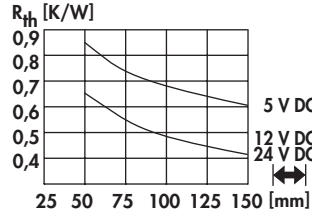

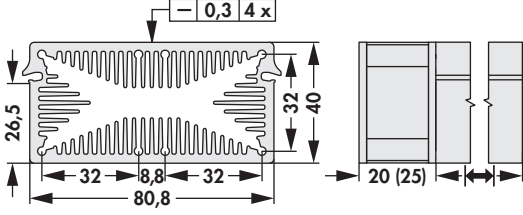
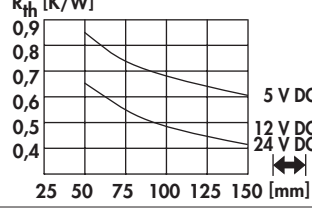

- compact design
- homogeneous heat distribution
- mounting possible on any side
- powerful axial-fan motor
- other lengths, special designs and machinings according to customer's specifications
- other surfaces, fan types and fan voltages upon request

art. no.			
LAM 4 D ...			
art. no.			
LAM 4 D K ...	with grooves for lock-in retaining spring for transistors THFU → A 165		
please indicate:	... \longleftrightarrow 50 75 100 125 150 mm	... fan type 5 = 5 V DC 12 = 12 V DC 24 = 24 V DC	
surface:	natural colour anodised		

Technical data of the fans

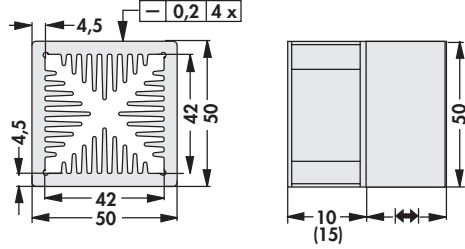
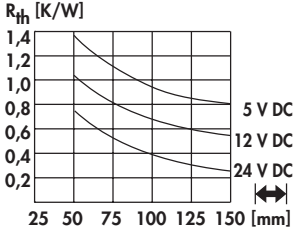
	... 5	... 12	... 24
type	ebmpapst 405	ebmpapst 412 JHH	ebmpapst 414 JHH
dimensions	40x40x20 mm	40x40x25 mm	40x40x25 mm
tension	5 V DC	12 V DC	24 V DC
power inout	0.9 W	3.3 W	3.6 W
max. air volume	10 m ³ /h	24 m ³ /h	24 m ³ /h
temperature range	-20°C... +70°C	-20°C... +60°C	-20°C... +60°C
noise level	18 dB(A)	46 dB(A)	46 dB(A)
speed	6,000 min ⁻¹	13,000 min ⁻¹	13,000 min ⁻¹
weight	27 g	50 g	50 g
failure rate (L₁₀)	L ₁₀ < 50,000 h (40°C) L ₁₀ < 20,000 h (tmax)	L ₁₀ < 57,500 h (40°C) L ₁₀ < 35,000 h (tmax)	L ₁₀ < 57,500 h (40°C) L ₁₀ < 35,000 h (tmax)

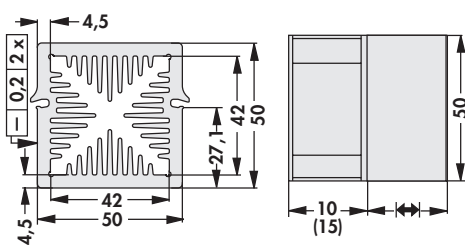
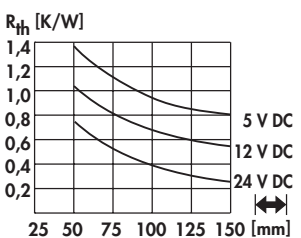
- compact design
- homogeneous heat distribution
- mounting possible on any side
- powerful axial-fan motor
- other lengths, special designs and machinings according to customer's specifications
- other surfaces, fan types and fan voltages upon request



art. no.			
LAM 5 ...			
art. no.			
LAM 5 K ...	with grooves for lock-in retaining spring for transistors THFU → A 165		
please indicate:	...  50 75 100 125 150 mm		... fan type 5 = 5 V DC 12 = 12 V DC 24 = 24 V DC
surface:	natural colour anodised		

Technical data of the fans

	... 5	... 12	... 24
type	Sepa, MFB 50 E 05 A	Sepa, MFB 50 E 12 A	ebmpapst 514 F
dimensions	50x50x10 mm	50x50x10 mm	50x50x15 mm
tension	5 V DC	12 V DC	24 V DC
max. air volume	10.1 m ³ /h	14.3 m ³ /h	20 m ³ /h
temperature range	-40°C... +85°C	-40°C... +85°C	-20°C... +70°C
speed	3,500 min ⁻¹	4,800 min ⁻¹	5,000 min ⁻¹
noise level	20 dB(A)	27 dB(A)	30 dB(A)
weight	19 g	19 g	27 g
failure rate (L₁₀)			L ₁₀ 50,000 h (20°C)
alarm output	with	with	

Miniature cooling aggregates

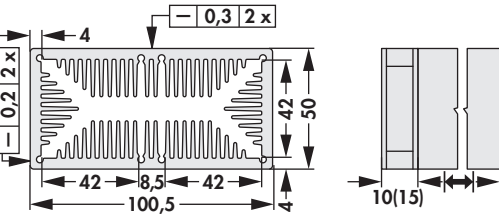
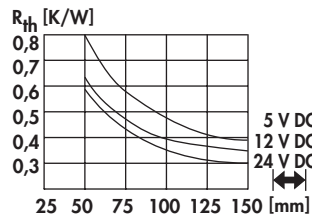

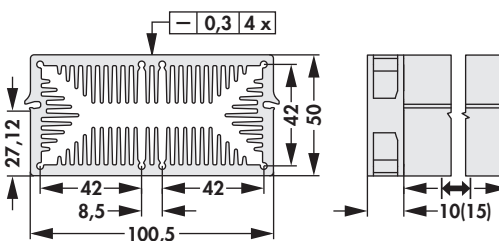
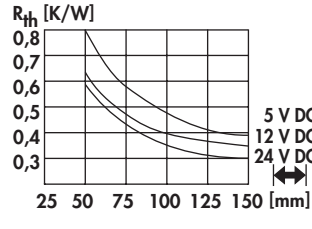
- compact design
- homogeneous heat distribution
- mounting possible on any side
- powerful axial-fan motor
- other lengths, special designs and machinings according to customer's specifications
- other surfaces, fan types and fan voltages upon request

<p>art. no.</p> <p>LAM 5 D ...</p>			
<p>art. no.</p> <p>LAM 5 D K ...</p>			
<p>with grooves for lock-in retaining spring for transistors THFU → A 165</p>			
<p>please indicate: ... \longleftrightarrow 50 75 100 125 150 mm ... fan type 5 = 5 V DC 12 = 12 V DC 24 = 24 V DC</p>			
<p>surface:</p>		<p>natural colour anodised</p>	

Technical data of the fans

	... 5	... 12	... 24
type	Sepa, MFB 50 E 05 A	Sepa, MFB 50 E 12 A	ebmpapst 514 F
dimensions	50x50x10 mm	50x50x10 mm	50x50x15 mm
tension	5 V DC	12 V DC	24 V DC
max. air volume	10.1 m ³ /h	14.3 m ³ /h	20 m ³ /h
temperature range	-40°C... +85°C	-40°C... +85°C	-20°C... +70°C
speed	3,500 min ⁻¹	4,800 min ⁻¹	5,000 min ⁻¹
noise level	20 dB(A)	27 dB(A)	30 dB(A)
weight	19 g	19 g	27 g
failure rate (L ₁₀)			L ₁₀ 50,000 h (20°C)
alarm output	with	with	

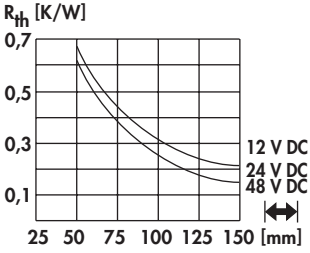

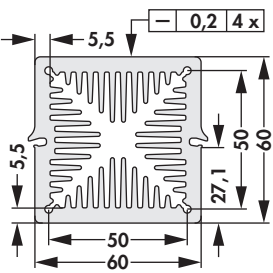
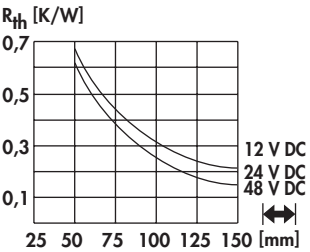
- compact design
- homogeneous heat distribution
- mounting possible on any side
- powerful axial-fan motor
- other lengths, special designs and machinings according to customer's specifications
- other surfaces, fan types and fan voltages upon request

art. no. LAM 6 ...			
art. no. LAM 6 K ...			
please indicate: ... $\left[\text{mm} \right]$ 50 75 100 125 150 mm		... fan type 12 = 12 V DC 24 = 24 V DC 48 = 48 V DC	
surface:		natural colour anodised	

Technical data of the fans

	... 12	... 24	... 48
type	ebmpapst 612 JH	ebmpapst 614 J/2HHP	ebmpapst 618 J/2HHP
dimensions	60x60x32 mm	60x60x32 mm	60x60x32 mm
tension	12 V DC	24 V DC	48 V DC
power inout	7.7 W	14.6 W	14.6 W
max. air volume	70 m ³ /h	82 m ³ /h	82 m ³ /h
temperature range	-20°C... +70°C	-20°C... 75°C	-20°C... 75°C
noise level	53 dB(A)	62 dB(A)	62 dB(A)
speed	11,700 min ⁻¹	15,000 min ⁻¹	15,000 min ⁻¹
weight	100 g	100 g	100 g
failure rate (L₁₀)	L ₁₀ > 57,500 h (40°C)	L ₁₀ > 65,000 h (40°C)	L ₁₀ > 65,000 h (40°C)

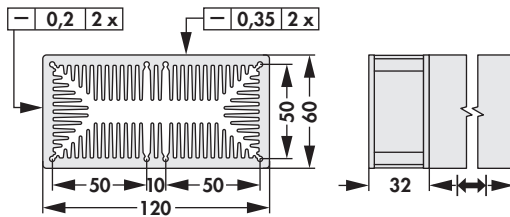
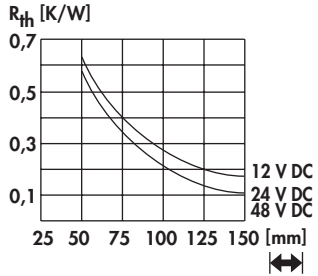

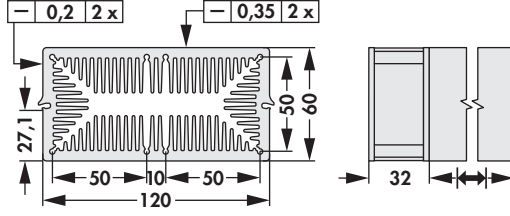
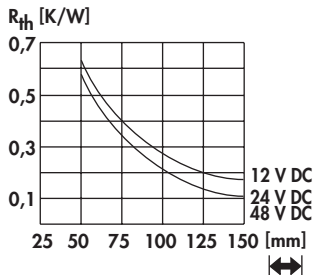
- compact design
- homogeneous heat distribution
- mounting possible on any side
- powerful axial-fan motor
- other lengths, special designs and machinings according to customer's specifications
- other surfaces, fan types and fan voltages upon request

<p>art. no.</p> <p>LAM 6 D ...</p>			
<p>art. no.</p> <p>LAM 6 D K ...</p>			
<p>please indicate: ... \longleftrightarrow</p> <p>50 75 100 125 150 mm</p>		<p>with grooves for lock-in retaining spring for transistors THFU → A 165</p> <p>... fan type</p> <p>12 = 12 V DC</p> <p>24 = 24 V DC</p> <p>48 = 48 V DC</p>	
<p>surface:</p>		<p>natural colour anodised</p>	

Technical data of the fans

	... 12	... 24	... 48
type	ebmpapst 612 JH	ebmpapst 614 J/2HHP	ebmpapst 618 J/2HHP
dimensions	60x60x32 mm	60x60x32 mm	60x60x32 mm
tension	12 V DC	24 V DC	48 V DC
power inout	7.7 W	14.6 W	14.6 W
max. air volume	70 m ³ /h	82 m ³ /h	82 m ³ /h
temperature range	-20°C... +70°C	-20°C... 75°C	-20°C... 75°C
noise level	53 dB(A)	62 dB(A)	62 dB(A)
speed	11,700 min ⁻¹	15,000 min ⁻¹	15,000 min ⁻¹
weight	100 g	100 g	100 g
failure rate (L ₁₀)	L ₁₀ > 57,500 h (40°C)	L ₁₀ > 65,000 h (40°C)	L ₁₀ > 65,000 h (40°C)

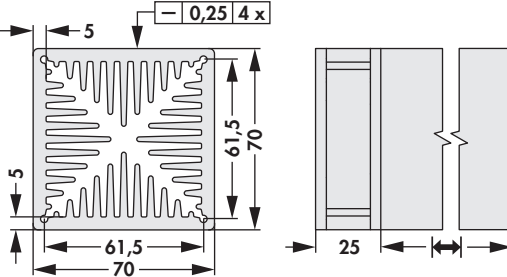
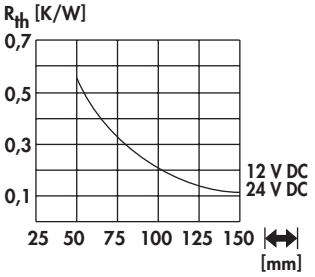
- compact design
- homogeneous heat distribution
- mounting possible on any side
- powerful axial-fan motor
- other lengths, special designs and machinings according to customer's specifications
- other surfaces, fan types and fan voltages upon request

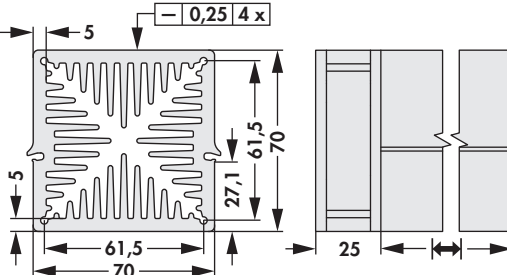
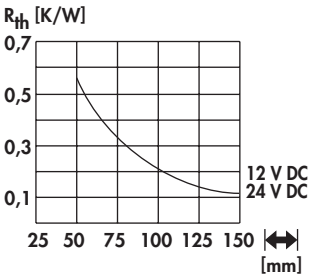

art. no. LAM 7 ...			
art. no. LAM 7 K ...			
<p>please indicate: ... $\left[\text{mm} \right]$... fan type</p> <p style="text-align: center;">100 125 150 200 250 mm 12 = 12 V DC 24 = 24 V DC</p>			
surface:		natural colour anodised	

Technical data of the fans

	... 12	... 24
type	ADDA AD0712UB-A7BGP	ADDA AD0724UB-A7BGP
dimensions	70x70x25 mm	70x70x25 mm
tension	12 V DC	24 V DC
power inout	5 W	6.2 W
max. air volume	82 m ³ /h	82 m ³ /h
temperature range	-10°C... +70°C	-10°C... +70°C
noise level	47.4 dB(A)	47.4 dB(A)
speed	5,000 min ⁻¹	5,000 min ⁻¹
weight	90 g	90 g
failure rate (L₁₀)	70.000 h (40°C)	70.000 h (40°C)

Heatsink-cooling aggregates

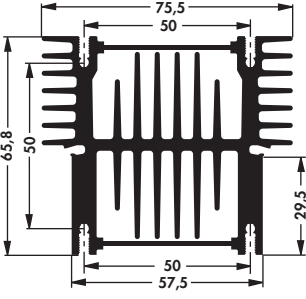
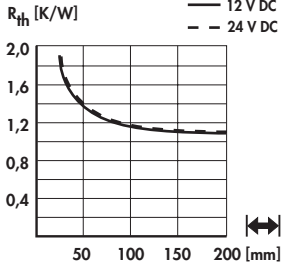
- screw-in solder pin M3 (art. no.: ELS 3)
- different lengths, special designs and machinings according to customer specifications
- different surfaces, fan types and fan voltages upon request



art. no.			
LA 27 K ...	with grooves for lock-in retaining spring for transistors THFU → A 165		
please indicate:	...  50 75 84 94 100 125 150 mm	... fan type	12 = 12 V DC 24 = 24 V DC

Technical data of the fans

	... 12	... 24
type	ebmpapst 612 NHH-118	ebmpapst 614 NHH-119
dimensions	60x60x25 mm	60x60x25 mm
tension	12 V DC	24 V DC
power inout	2.9 W	2.9 W
max. air volume	56 m ³ /h	56 m ³ /h
temperature range	-20°C... +70°C	-20°C... +70°C
noise level	41 dB(A)	41 dB(A)
speed	6,800 min ⁻¹	6,850 min ⁻¹
weight	66 g	66 g
failure rate (L₁₀)	L ₁₀ > 60,000 h (40°C)	L ₁₀ > 60,000 h (40°C)

Heatsink-cooling aggregates

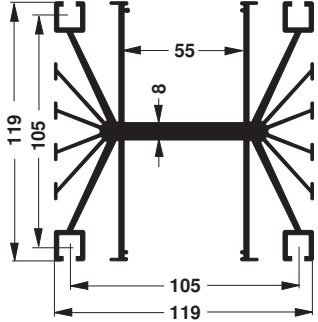
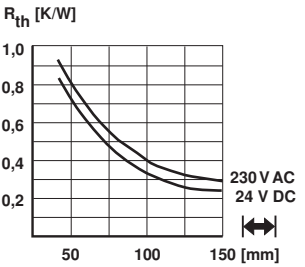
- especially suitable for IGBT, SSR, semiconductor modules, high performance transistors etc.
- effective construction with axial fans
- good thermal performance
- additional machining according to customer's instructions
- cooling aggregates also available without fans
- other fan types and fan voltages on request

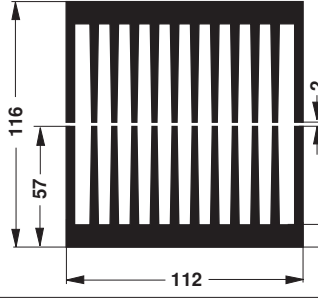
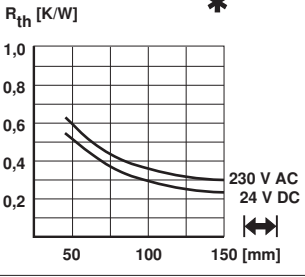



art. no. LA 4 ...			
art. no. LA 5 ...			
please indicate: ... $\left[\right]$ 75 100 150 mm		... fan type 24 = 24 V DC 230 = 230 V AC	

Technical data of the fans

	... 24	... 230
type	ebmpapst 4184NXH	ebmpapst 4656N
dimensions	119x119x38 mm	119x119x38 mm
tension	24 V DC	230 V AC
power inout	11 W	19 W
max. air volume	237 m ³ /h	160 m ³ /h
temperature range	-30°C ... +70°C	-40°C... +85°C
noise level	57 dB(A)	47 dB(A)
speed	4,400 min ⁻¹	2,650 min ⁻¹
weight	390 g	550 g
failure rate (L₁₀)	L ₁₀ > 70,000 h (40°C)	L ₁₀ > 37,500 h (40°C)

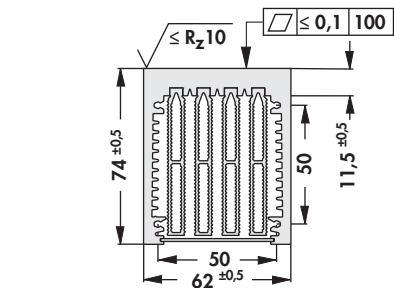
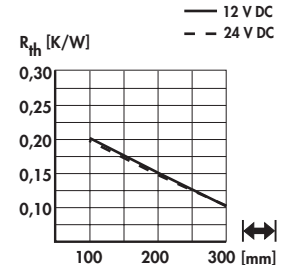
Hollow-fin cooling aggregates

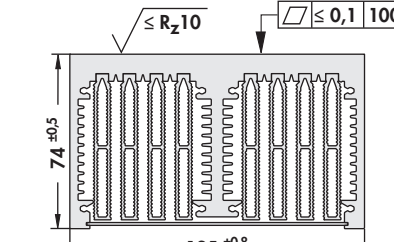
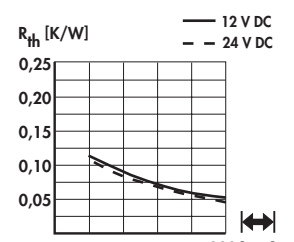
- geometry of hollow fin optimising the air flow
- particularly effective heat dissipation
- compact construction
- milled flat semiconductor mounting surface
- other fan types and fan voltages on request

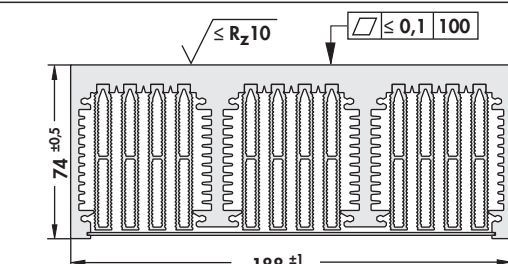
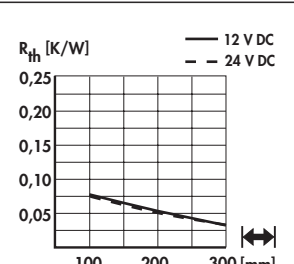



art. no.			
LA 6 ...	without air flow chamber		
art. no.			
LA 7 ...	without air flow chamber		
art. no.			
LA 8 ...	without air flow chamber		
<p>please indicate: ... \longleftrightarrow 100 150 200 250 300 mm</p> <p>... fan type 12 = 12 V DC 24 = 24 V DC</p>			

Technical data of the fans

	... 12	... 24
type	ebmpapst 612 NHH-118	ebmpapst 614 NHH-119
dimensions	60x60x25 mm	60x60x25 mm
tension	12 V DC	24 V DC
power inout	2.9 W	2.9 W
max. air volume	56 m ³ /h	56 m ³ /h
temperature range	-20°C... +70°C	-20°C... +70°C
noise level	41 dB(A)	41 dB(A)
speed	6,800 min ⁻¹	6,850 min ⁻¹
weight	66 g	66 g
failure rate (L₁₀)	L ₁₀ > 60,000 h (40°C)	L ₁₀ > 60,000 h (40°C)

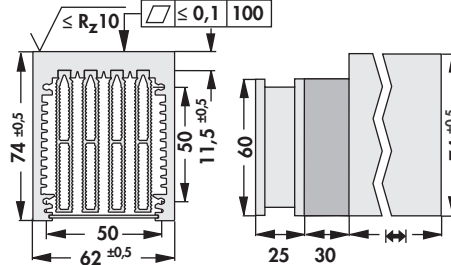
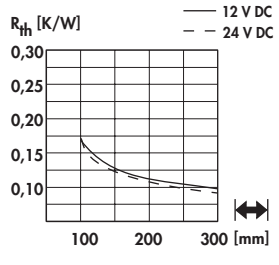
Hollow-fin cooling aggregates

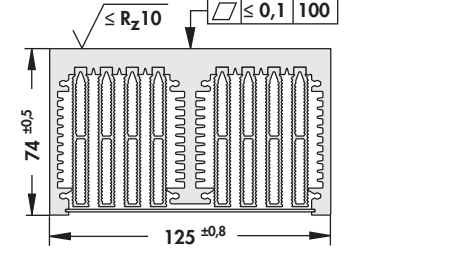
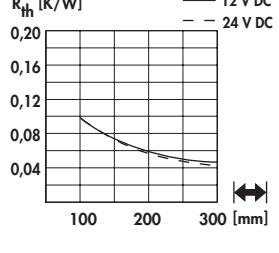
- geometry of hollow fin optimising the air flow
- particularly effective heat dissipation
- compact construction
- milled flat semiconductor mounting surface
- other fan types and fan voltages on request

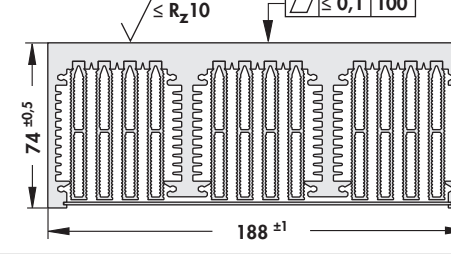
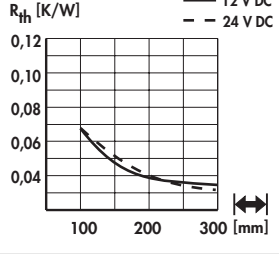





<p>art. no.</p> <p>LA V 6 ...</p>			
<p>with air flow chamber</p>			
<p>art. no.</p> <p>LA V 7 ...</p>			
<p>with air flow chamber</p>			
<p>art. no.</p> <p>LA V 8 ...</p>			
<p>with air flow chamber</p>			
<p>please indicate: ... \longleftrightarrow 100 150 200 250 300 mm</p>		<p>... fan type 12 = 12 V DC 24 = 24 V DC</p>	

Technical data of the fans

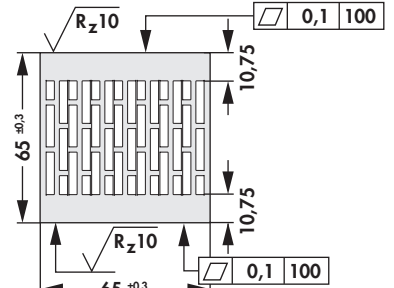
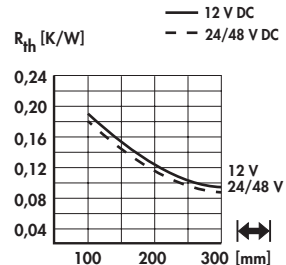
	... 12	... 24
type	ebmpapst 612 NHH-118	ebmpapst 614 NHH-119
dimensions	60x60x25 mm	60x60x25 mm
tension	12 V DC	24 V DC
power inout	2.9 W	2.9 W
max. air volume	56 m ³ /h	56 m ³ /h
temperature range	-20°C... +70°C	-20°C... +70°C
noise level	41 dB(A)	41 dB(A)
speed	6,800 min ⁻¹	6,850 min ⁻¹
weight	66 g	66 g
failure rate (L₁₀)	L ₁₀ > 60,000 h (40°C)	L ₁₀ > 60,000 h (40°C)

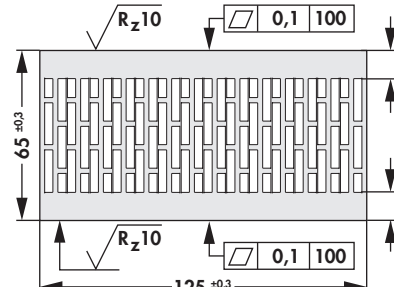
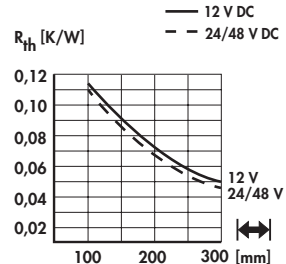
High performance cooling aggregate

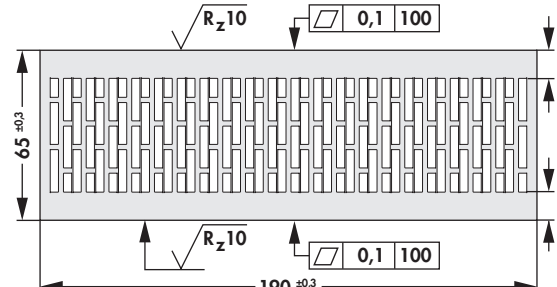
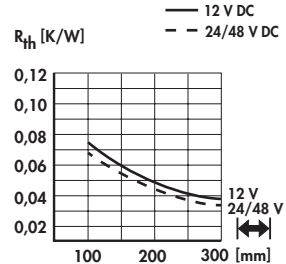
- compact construction by means of connected extruded profiles
- excellent efficiency by means of flow-optimised hollow fin structure
- powerful axial fans
- double-sided precise milled semiconductor mounting surfaces
- different width dimensions, customised machinings, surfaces, fan types and fan voltages upon request





art. no. LA 28 ...			
without air flow chamber			
art. no. LA 29 ...			
without air flow chamber			
art. no. LA 30 ...			
without air flow chamber			
<p>please indicate: ...  100 150 200 250 300 mm</p> <p style="text-align: right;">... fan type 12 = 12 V DC 24 = 24 V DC 48 = 48 V DC</p>			

Technical data of the fans

	... 12	... 24	... 48
type	ebmpapst 612 JH	ebmpapst 614 J/2HHP	ebmpapst 618 J/2HHP
dimensions	60x60x32 mm	60x60x32 mm	60x60x32 mm
tension	12 V DC	24 V DC	48 V DC
power inout	7.7 W	14.6 W	14.6 W
max. air volume	70 m ³ /h	82 m ³ /h	82 m ³ /h
temperature range	-20°C... +70°C	-20°C... 75°C	-20°C... 75°C
noise level	53 dB(A)	62 dB(A)	62 dB(A)
speed	11,700 min ⁻¹	15,000 min ⁻¹	15,000 min ⁻¹
weight	100 g	100 g	100 g
failure rate (L₁₀)	L ₁₀ > 57,500 h (40°C)	L ₁₀ > 65,000 h (40°C)	L ₁₀ > 65,000 h (40°C)

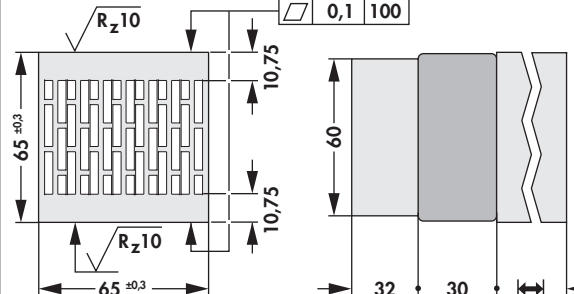
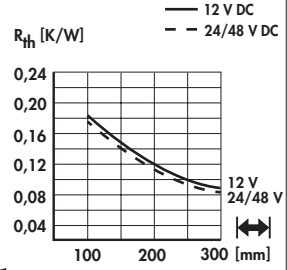
High performance cooling aggregate

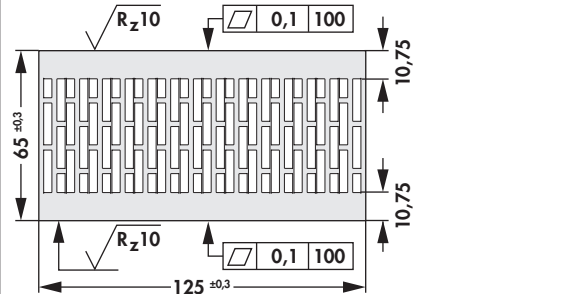
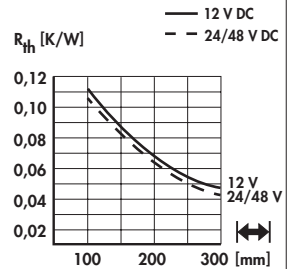
- additional efficiency enhancement and noise reduction by means of air-technically adjusted airflow chambers
- excellent thermal efficiency in connection with powerful axial fans
- double-sided precise milled semiconductor mounting surfaces
- different width dimensions, customised machinings, surfaces, fan types and fan voltages upon request

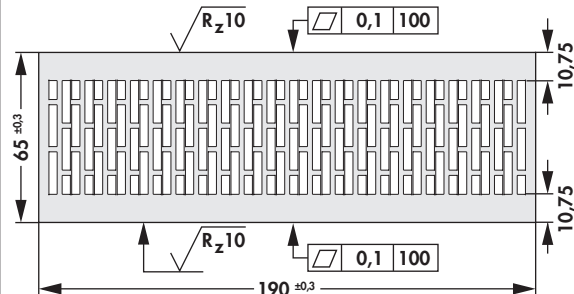
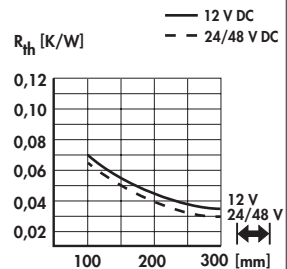



<p>art. no.</p> <p>LA V 28 ...</p>			
<p>with air flow chamber</p>			
<p>art. no.</p> <p>LA V 29 ...</p>			
<p>with air flow chamber</p>			
<p>art. no.</p> <p>LA V 30 ...</p>			
<p>with air flow chamber</p>			
<p>please indicate: ... \longleftrightarrow 100 150 200 250 300 mm</p>		<p>... fan type 12 = 12 V DC 24 = 24 V DC 48 = 48 V DC</p>	

Technical data of the fans

	... 12	... 24	... 48
type	ebmpapst 612 JH	ebmpapst 614 J/2HHP	ebmpapst 618 J/2HHP
dimensions	60x60x32 mm	60x60x32 mm	60x60x32 mm
tension	12 V DC	24 V DC	48 V DC
power inout	7.7 W	14.6 W	14.6 W
max. air volume	70 m ³ /h	82 m ³ /h	82 m ³ /h
temperature range	-20°C... +70°C	-20°C... 75°C	-20°C... 75°C
noise level	53 dB(A)	62 dB(A)	62 dB(A)
speed	11,700 min ⁻¹	15,000 min ⁻¹	15,000 min ⁻¹
weight	100 g	100 g	100 g
failure rate (L ₁₀)	L ₁₀ > 57,500 h (40°C)	L ₁₀ > 65,000 h (40°C)	L ₁₀ > 65,000 h (40°C)

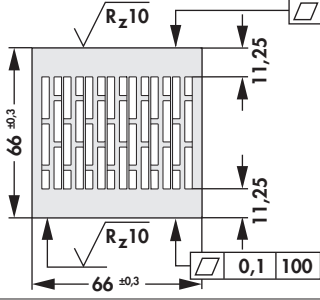
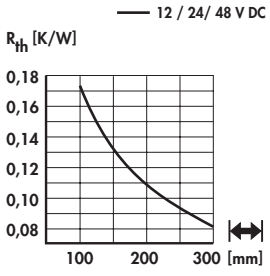
High performance cooling aggregate

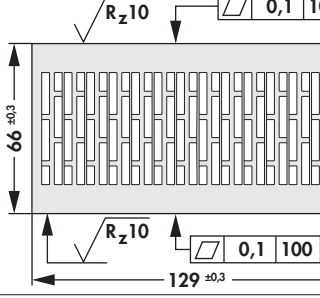
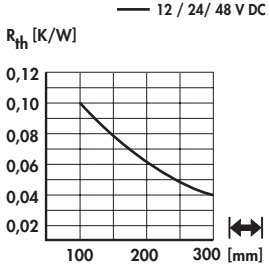
- compact construction by means of connected extruded profiles
- excellent efficiency by means of flow-optimised hollow fin structure
- powerful axial fans
- double-sided precise milled semiconductor mounting surfaces
- different width dimensions, customised machinings, surfaces, fan types and fan voltages upon request

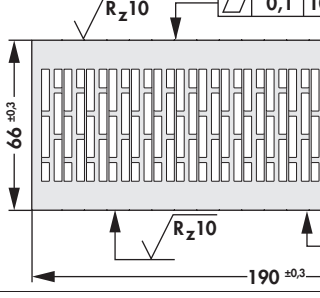
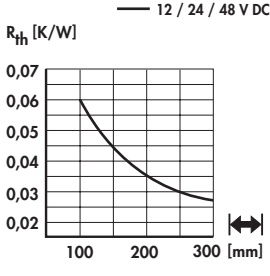
art. no. 			
LA HB 4 ... without air flow chamber			
art. no. 			
LA HB 5 ... without air flow chamber			
art. no. 			
LA HB 6 ... without air flow chamber			
<p>please indicate: ... \longleftrightarrow 100 150 200 250 300 mm</p> <p>... fan type 12 = 12 V DC 24 = 24 V DC 48 = 48 V DC</p>			

Technical data of the fans

	... 12	... 24	... 48
type	ADDA AS06012		
dimensions	60x60x38 mm	60x60x38 mm	60x60x38 mm
tension	12 V DC	24 V DC	48 V DC
power inout	36 W	36 W	36 W
max. air volume	145 m ³ /h	145 m ³ /h	145 m ³ /h
temperature range	-10°C... +70°C	-10°C... +70°C	-10°C... +70°C
noise level	69.5 dB(A)	69.5 dB(A)	69.5 dB(A)
speed	16.000 min ⁻¹	16.000 min ⁻¹	16.000 min ⁻¹
weight	125 g	125 g	125 g
failure rate (L₁₀)	70.000 h (40°C)	70.000 h (40°C)	70.000 h (40°C)

- additional efficiency enhancement and noise reduction by means of air-technically adjusted airflow chambers
- excellent thermal efficiency in connection with powerful axial fans
- double-sided precise milled semiconductor mounting surfaces
- different width dimensions, customised machinings, surfaces, fan types and fan voltages upon request







art. no.			
LA V HB 4 ...	with air flow chamber		
art. no.			
LA V HB 5 ...	with air flow chamber		
art. no.			
LA V HB 6 ...	with air flow chamber		
please indicate:	... \longleftrightarrow 100 150 200 250 300 mm	... fan type 12 = 12 V DC 24 = 24 V DC 48 = 48 V DC	

Technical data of the fans

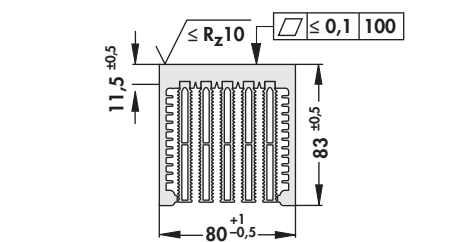
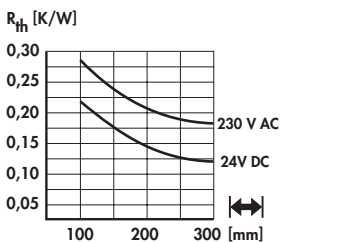
	... 12	... 24	... 48
type	ADDA AS06012		
dimensions	60x60x38 mm	60x60x38 mm	60x60x38 mm
tension	12 V DC	24 V DC	48 V DC
power in/out	36 W	36 W	36 W
max. air volume	145 m ³ /h	145 m ³ /h	145 m ³ /h
temperature range	-10°C... +70°C	-10°C... +70°C	-10°C... +70°C
noise level	69.5 dB(A)	69.5 dB(A)	69.5 dB(A)
speed	16.000 min ⁻¹	16.000 min ⁻¹	16.000 min ⁻¹
weight	125 g	125 g	125 g
failure rate (L₁₀)	70.000 h (40°C)	70.000 h (40°C)	70.000 h (40°C)

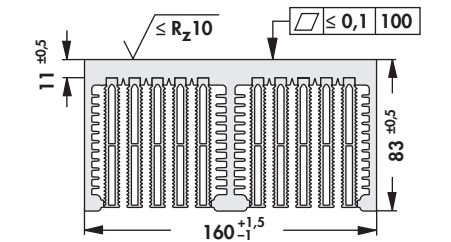
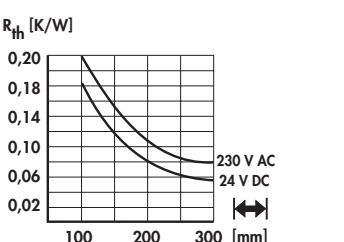
Hollow-fin cooling aggregates

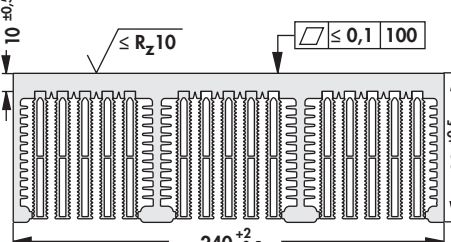
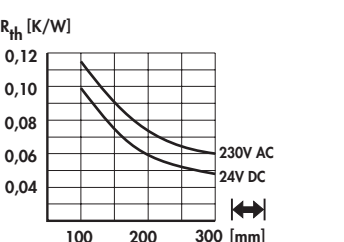
- geometry of hollow fin optimising the air flow
- particularly effective heat dissipation
- compact construction
- milled flat semiconductor mounting surface
- other fan types and fan voltages on request





art. no.			
LA 9 ...	without air flow chamber		
art. no.			
LA 10 ...	without air flow chamber		
art. no.			
LA 11 ...	without air flow chamber		
please indicate: ...  100 150 200 250 300 mm		... fan type 24 = 24 V DC 230 = 230 V AC	

Technical data of the fans

	... 24	... 230
type	ebmpapst 8314H	ebmpapst 8556N
dimensions	80x80x32 mm	80x80x38 mm
tension	24 V DC	230 V AC
power inout	6 W	12 W
max. air volume	80 m ³ /h	50 m ³ /h
temperature range	-20°C... 75°C	-40°C... +90°C
noise level	48 dB(A)	31 dB(A)
speed	5,000 min ⁻¹	2,800 min ⁻¹
weight	170 g	490 g
failure rate (L₁₀)	L ₁₀ > 55,000 h (40°C)	L ₁₀ > 52,500 h (40°C)

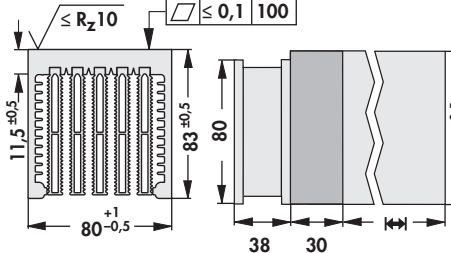
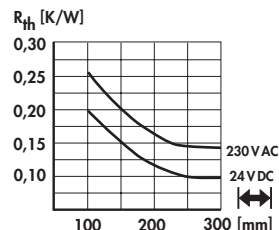
Hollow-fin cooling aggregates

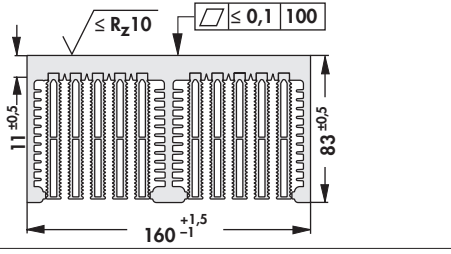
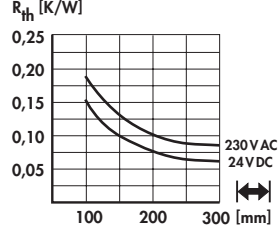
- geometry of hollow fin optimising the air flow
- particularly effective heat dissipation
- compact construction
- milled flat semiconductor mounting surface
- other fan types and fan voltages on request

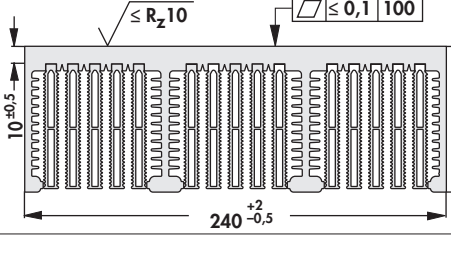
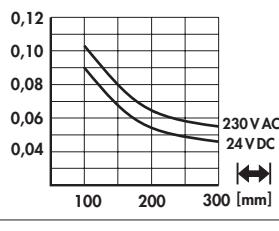



<p>art. no.</p> <p>LA V 9 ...</p>			
<p>with air flow chamber</p>			
<p>art. no.</p> <p>LA V 10 ...</p>			
<p>with air flow chamber</p>			
<p>art. no.</p> <p>LA V 11 ...</p>			
<p>with air flow chamber</p>			
<p>please indicate: ... \longleftrightarrow 100 150 200 250 300 mm</p>		<p>... fan type 24 = 24 V DC 230 = 230 V AC</p>	

Technical data of the fans

	... 24	... 230
type	ebmpapst 8314H	ebmpapst 8556N
dimensions	80x80x32 mm	80x80x38 mm
tension	24 V DC	230 V AC
power inout	6 W	12 W
max. air volume	80 m ³ /h	50 m ³ /h
temperature range	-20°C... 75°C	-40°C... +90°C
noise level	48 dB(A)	31 dB(A)
speed	5,000 min ⁻¹	2,800 min ⁻¹
weight	170 g	490 g
failure rate (L ₁₀)	L ₁₀ > 55,000 h (40°C)	L ₁₀ > 52,500 h (40°C)

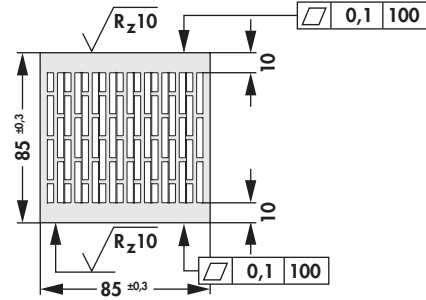
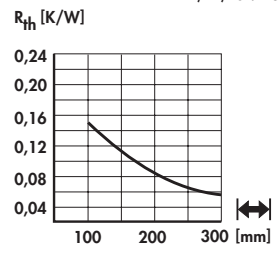
High performance cooling aggregate

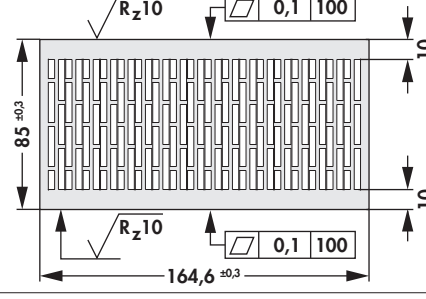
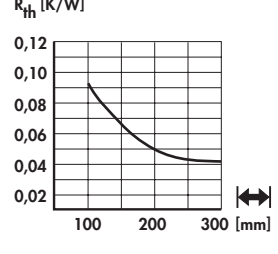
- compact construction by means of connected extruded profiles
- excellent efficiency by means of flow-optimised hollow fin structure
- powerful axial fans
- double-sided precise milled semiconductor mounting surfaces
- different width dimensions, customised machinings, surfaces, fan types and fan voltages upon request

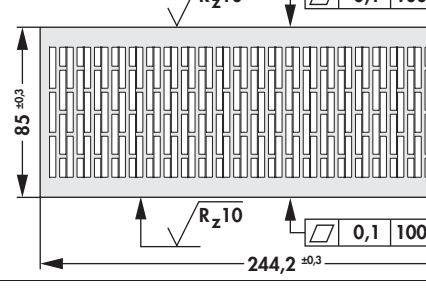
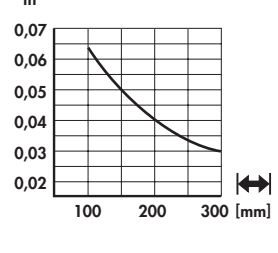



art. no. LA 31 ...			
without air flow chamber			
art. no. LA 32 ...			
without air flow chamber			
art. no. LA 33 ...			
without air flow chamber			
please indicate: ... \longleftrightarrow 100 150 200 250 300 mm ... fan type 12 = 12 V DC 24 = 24 V DC 48 = 48 V DC			

Technical data of the fans

	... 12	... 24	... 48
type	ebmpapst 8212 JH4	ebmpapst 8214 JH4	ebmpapst 8218 JH4
dimensions	80x80x38 mm	80x80x38 mm	80x80x38 mm
tension	12 V DC	24 V DC	48 V DC
power inout	39 W	38 W	36 W
max. air volume	222 m ³ /h	222 m ³ /h	222 m ³ /h
temperature range	-20°C... +70°C	-20°C... +70°C	-20°C... +70°C
noise level	71 dB(A)	71 dB(A)	71 dB(A)
speed	14,000 min ⁻¹	14,000 min ⁻¹	14,000 min ⁻¹
weight	200 g	200 g	200 g
failure rate (L₁₀)	L ₁₀ > 50,000 h (40°C)	L ₁₀ > 50,000 h (40°C)	L ₁₀ > 50,000 h (40°C)

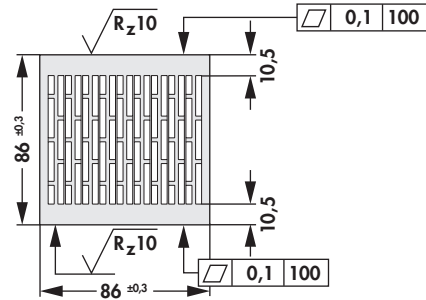
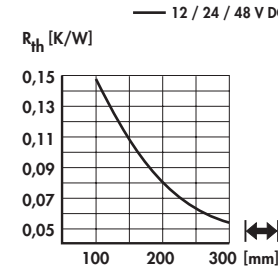
High performance cooling aggregate

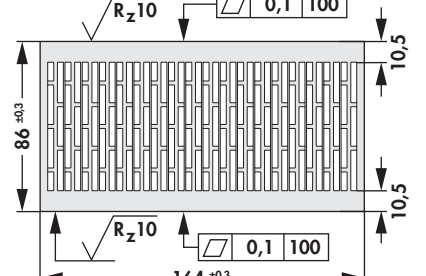
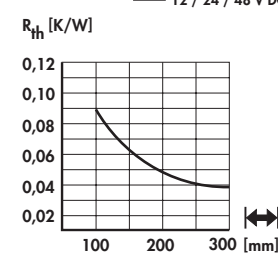
- compact construction by means of connected extruded profiles
- excellent efficiency by means of flow-optimised hollow fin structure
- powerful axial fans
- double-sided precise milled semiconductor mounting surfaces
- different width dimensions, customised machinings, surfaces, fan types and fan voltages upon request

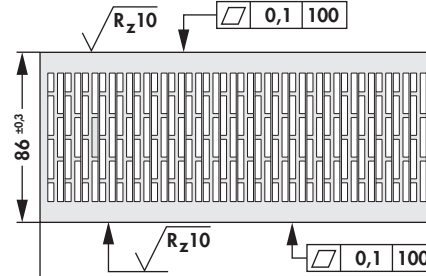
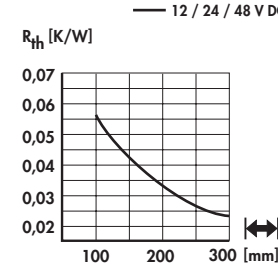



art. no. LA HB 7 ...			
without air flow chamber			
art. no. LA HB 8 ...			
without air flow chamber			
art. no. LA HB 9 ...			
without air flow chamber			
<p>please indicate: ... $\left[\text{mm} \right]$... fan type</p> <p style="margin-left: 100px;">100 150 200 250 300 mm</p> <p style="margin-left: 100px;">12 = 12 V DC 24 = 24 V DC 48 = 48 V DC</p>			

Technical data of the fans

	... 12	... 24	... 48
type			
dimensions	80x80x38 mm	80x80x38 mm	80x80x38 mm
tension	12 V DC	24 V DC	48 V DC
power inout	69.6 W	60 W	72 W
max. air volume	230 m ³ /h	230 m ³ /h	230 m ³ /h
temperature range	-10°C... +70°C	-10°C... +70°C	-10°C... +70°C
noise level	73.1 dB(A)	73.1 dB(A)	73.1 dB(A)
speed	13.500 min ⁻¹	13.500 min ⁻¹	13.500 min ⁻¹
weight	225 g	219 g	219 g
failure rate (L₁₀)	70.000 h (40°C)	70.000 h (40°C)	70.000 h (40°C)

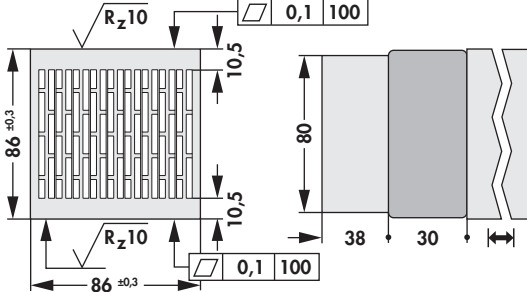
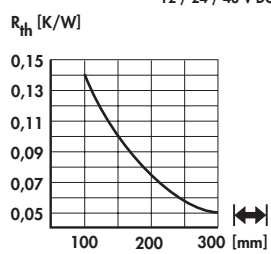
High performance cooling aggregate

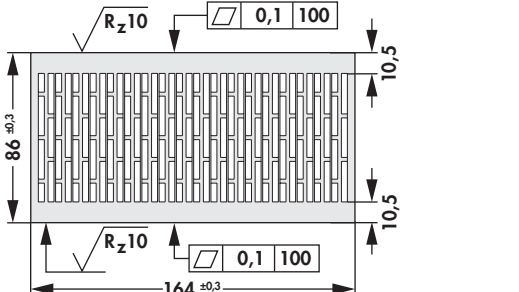
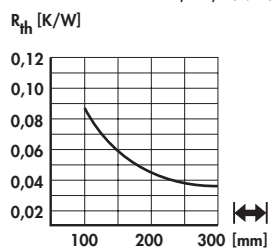
- additional efficiency enhancement and noise reduction by means of air-technically adjusted airflow chambers
- excellent thermal efficiency in connection with powerful axial fans
- double-sided precise milled semiconductor mounting surfaces
- different width dimensions, customised machinings, surfaces, fan types and fan voltages upon request

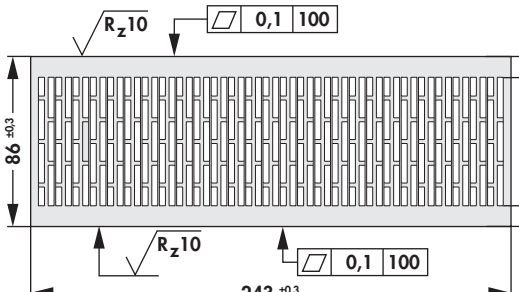
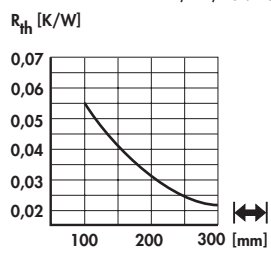



<p>art. no.</p>  <p>LA V HB 7 ...</p>	<p>with air flow chamber</p>		 <p>— 12 / 24 / 48 V DC</p>
<p>art. no.</p>  <p>LA V HB 8 ...</p>	<p>with air flow chamber</p>		 <p>— 12 / 24 / 48 V DC</p>
<p>art. no.</p>  <p>LA V HB 9 ...</p>	<p>with air flow chamber</p>		 <p>— 12 / 24 / 48 V DC</p>
<p>please indicate:</p> <p>... \longleftrightarrow 100 150 200 250 300 mm</p> <p>... fan type</p> <p>12 = 12 V DC</p> <p>24 = 24 V DC</p> <p>48 = 48 V DC</p>			

Technical data of the fans

	... 12	... 24	... 48
type			
dimensions	80x80x38 mm	80x80x38 mm	80x80x38 mm
tension	12 V DC	24 V DC	48 V DC
power in/out	69.6 W	60 W	72 W
max. air volume	230 m ³ /h	230 m ³ /h	230 m ³ /h
temperature range	-10°C... +70°C	-10°C... +70°C	-10°C... +70°C
noise level	73.1 dB(A)	73.1 dB(A)	73.1 dB(A)
speed	13.500 min ⁻¹	13.500 min ⁻¹	13.500 min ⁻¹
weight	225 g	219 g	219 g
failure rate (L₁₀)	70.000 h (40°C)	70.000 h (40°C)	70.000 h (40°C)

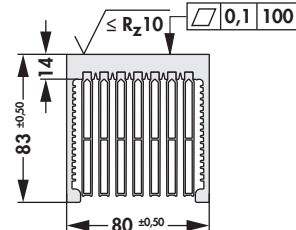
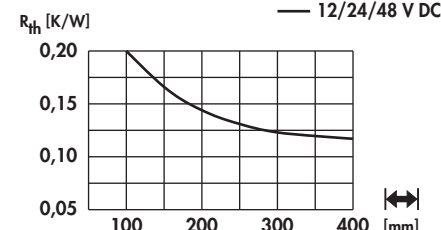
Hollow-fin cooling aggregates

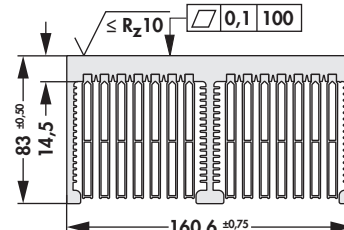
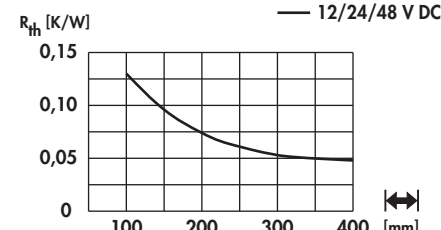
- hollow-fin geometry of new conception
- enlarged surface due to larger fin quantity
- effective heat dissipation with low pressure drop
- available with and without air-flow chamber
- milled flat semiconductor mounting surface
- mechanical treatments according to customer's specifications

art. no. LA 34 ...			 <p style="text-align: right;">— 12/24/48 V DC</p>
without air flow chamber			
art. no. LA 35 ...			 <p style="text-align: right;">— 12/24/48 V DC</p>
without air flow chamber			
please indicate: ...  100 150 200 250 300 mm		... fan type 12 = 12 V DC 24 = 24 V DC 48 = 48 V DC	

Technical data of the fans

	... 12	... 48	... 24
type	ebmpapst 8212 JH4	ebmpapst 8218 JH4	ebmpapst 8214 JH4
dimensions	80x80x38 mm	80x80x38 mm	80x80x38 mm
tension	12 V DC	48 V DC	24 V DC
power inout	39 W	36 W	38 W
max. air volume	222 m ³ /h	222 m ³ /h	222 m ³ /h
temperature range	-20°C... +70°C	-20°C... +70°C	-20°C... +70°C
noise level	71 dB(A)	71 dB(A)	71 dB(A)
speed	14,000 min ⁻¹	14,000 min ⁻¹	14,000 min ⁻¹
weight	200 g	200 g	200 g
failure rate (L₁₀)	L ₁₀ > 50,000 h (40°C)	L ₁₀ > 50,000 h (40°C)	L ₁₀ > 50,000 h (40°C)

Hollow-fin cooling aggregates

- hollow-fin geometry of new conception
- enlarged surface due to larger fin quantity
- effective heat dissipation with low pressure drop
- available with and without air-flow chamber
- milled flat semiconductor mounting surface
- mechanical treatments according to customer's specifications

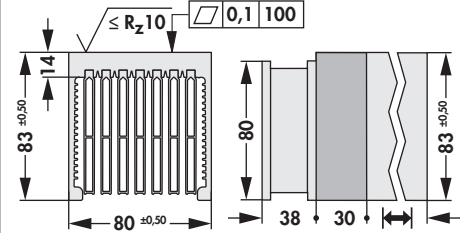
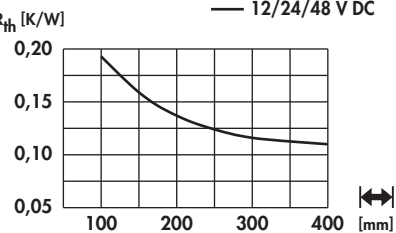
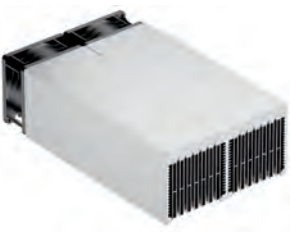
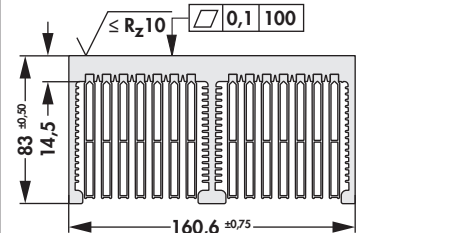
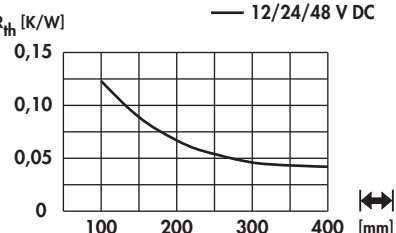



<p>art. no.</p> <p>LA V 34 ...</p>	 <p>with air flow chamber</p>		<p>R_{th} [K/W] — 12/24/48 V DC</p> 
<p>art. no.</p> <p>LA V 35 ...</p>	 <p>with air flow chamber</p>		<p>R_{th} [K/W] — 12/24/48 V DC</p> 
<p>please indicate: ... \longleftrightarrow</p> <p>100 150 200 250 300 mm</p>		<p>... fan type</p> <p>12 = 12 V DC</p> <p>24 = 24 V DC</p> <p>48 = 48 V DC</p>	

Technical data of the fans

	... 12	... 48	... 24
type	ebmpapst 8212 JH4	ebmpapst 8218 JH4	ebmpapst 8214 JH4
dimensions	80x80x38 mm	80x80x38 mm	80x80x38 mm
tension	12 V DC	48 V DC	24 V DC
power inout	39 W	36 W	38 W
max. air volume	222 m ³ /h	222 m ³ /h	222 m ³ /h
temperature range	-20°C... +70°C	-20°C... +70°C	-20°C... +70°C
noise level	71 dB(A)	71 dB(A)	71 dB(A)
speed	14,000 min ⁻¹	14,000 min ⁻¹	14,000 min ⁻¹
weight	200 g	200 g	200 g
failure rate (L₁₀)	L ₁₀ > 50,000 h (40°C)	L ₁₀ > 50,000 h (40°C)	L ₁₀ > 50,000 h (40°C)

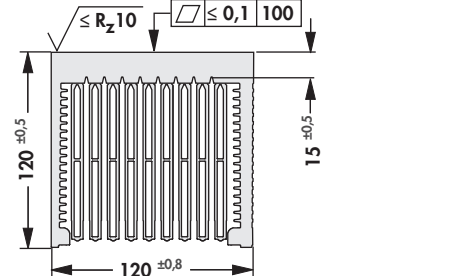
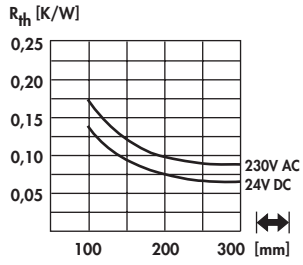
Hollow-fin cooling aggregates

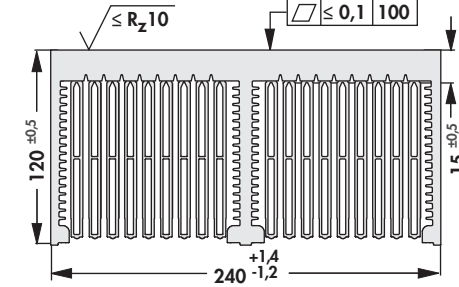
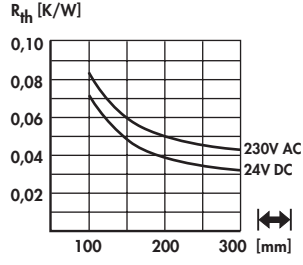
- extremely low losses due to optimised hollow fin geometry
- particularly effective heat dissipation
- compact design with axial fan
- milled flat semiconductor mounting surface
- additional design to customer's instructions
- other fan types and fan voltages on request



art. no. LA 14 ...			
without air flow chamber			
art. no. LA 15 ...			
without air flow chamber			
please indicate: ...  100 150 200 250 300 400 mm		... fan type 24 = 24 V DC 230 = 230 V AC	

Technical data of the fans

	... 24	... 230
type	ebmpapst 4184NXH	ebmpapst 4656N
dimensions	119x119x38 mm	119x119x38 mm
tension	24 V DC	230 V AC
power inout	11 W	19 W
max. air volume	237 m ³ /h	160 m ³ /h
temperature range	-30°C ... +70°C	-40°C... +85°C
noise level	57 dB(A)	47 dB(A)
speed	4,400 min ⁻¹	2,650 min ⁻¹
weight	390 g	550 g
failure rate (L₁₀)	L ₁₀ > 70,000 h (40°C)	L ₁₀ > 37,500 h (40°C)

Hollow-fin cooling aggregates

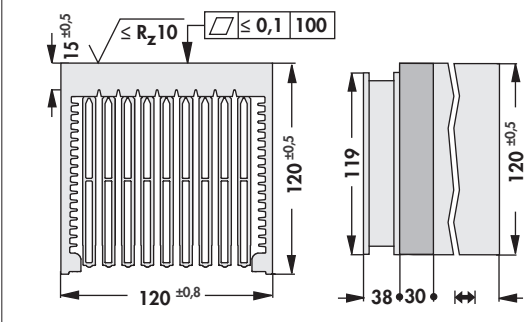
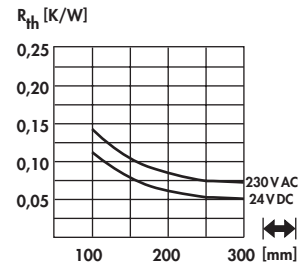
- extremely low losses due to optimised hollow fin geometry
- particularly effective heat dissipation
- compact design with axial fan
- milled flat semiconductor mounting surface
- additional design to customer's instructions on request
- other fan types and fan voltages on request

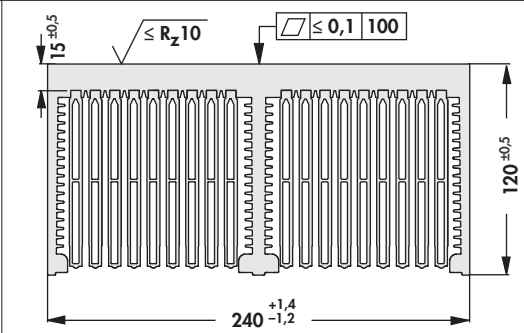
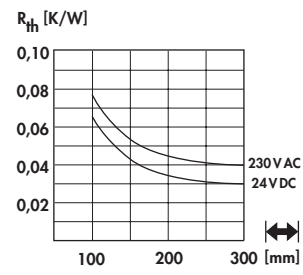



art. no.			
LA V 14 ...	with air flow chamber		
art. no.			
LA V 15 ...	with air flow chamber		
please indicate:	... $\left[\begin{array}{c} \leftarrow \rightleftarrows \rightarrow \end{array} \right]$ 100 150 200 250 300 400 mm		... fan type 24 = 24 V DC 230 = 230 V AC

Technical data of the fans

	... 24	... 230
type	ebmpapst 4184NXH	ebmpapst 4656N
dimensions	119x119x38 mm	119x119x38 mm
tension	24 V DC	230 V AC
power in/out	11 W	19 W
max. air volume	237 m ³ /h	160 m ³ /h
temperature range	-30°C ... +70°C	-40°C... +85°C
noise level	57 dB(A)	47 dB(A)
speed	4,400 min ⁻¹	2,650 min ⁻¹
weight	390 g	550 g
failure rate (L₁₀)	L ₁₀ > 70,000 h (40°C)	L ₁₀ > 37,500 h (40°C)

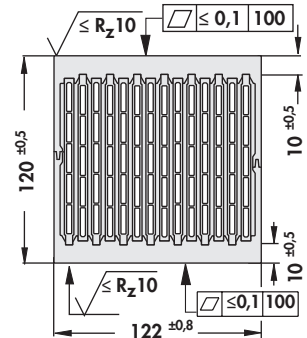
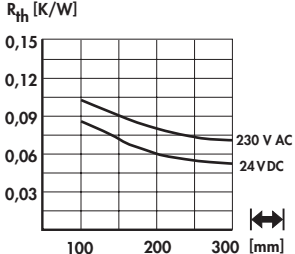
Hollow-fin cooling aggregates

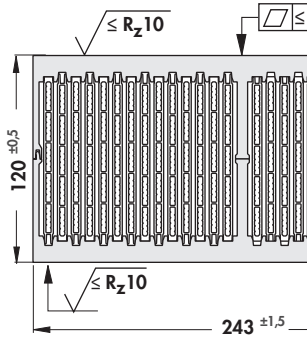
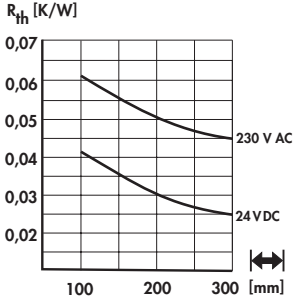
- extremely low losses due to optimised hollow fin geometry
- effective heat dissipation
- compact construction with axial fans
- two opposite mounting surfaces are milled flat
- additional treatment upon customer's request
- other fan types and fan voltages on request

art. no. 		
LA 17 ...	without air flow chamber	
art. no. 		
LA 18 ...	without air flow chamber	
please indicate: ...  100 150 200 250 300 400 mm ... fan type 24 = 24 V DC 230 = 230 V AC		

Technical data of the fans

	... 24	... 230
type	ebmpapst 4184NXH	ebmpapst 4656N
dimensions	119x119x38 mm	119x119x38 mm
tension	24 V DC	230 V AC
power inout	11 W	19 W
max. air volume	237 m ³ /h	160 m ³ /h
temperature range	-30°C ... +70°C	-40°C... +85°C
noise level	57 dB(A)	47 dB(A)
speed	4,400 min ⁻¹	2,650 min ⁻¹
weight	390 g	550 g
failure rate (L₁₀)	L ₁₀ > 70,000 h (40°C)	L ₁₀ > 37,500 h (40°C)

Hollow-fin cooling aggregates

- extremely low losses due to optimised hollow fin geometry
- effective heat dissipation
- compact construction with axial fans
- two opposite mounting surfaces are milled flat
- additional treatment upon customer's request
- other fan types and fan voltages on request

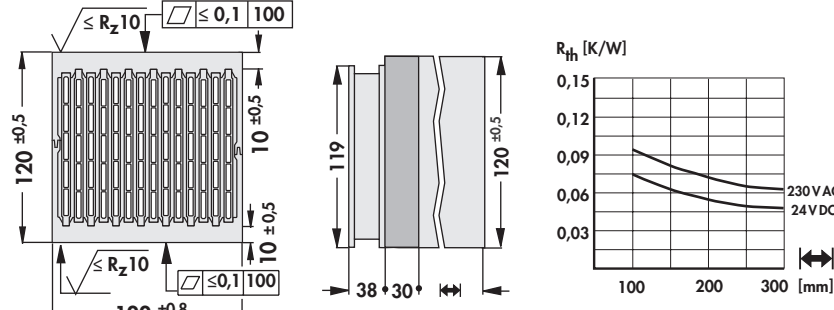
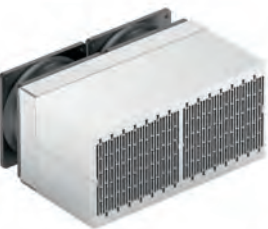
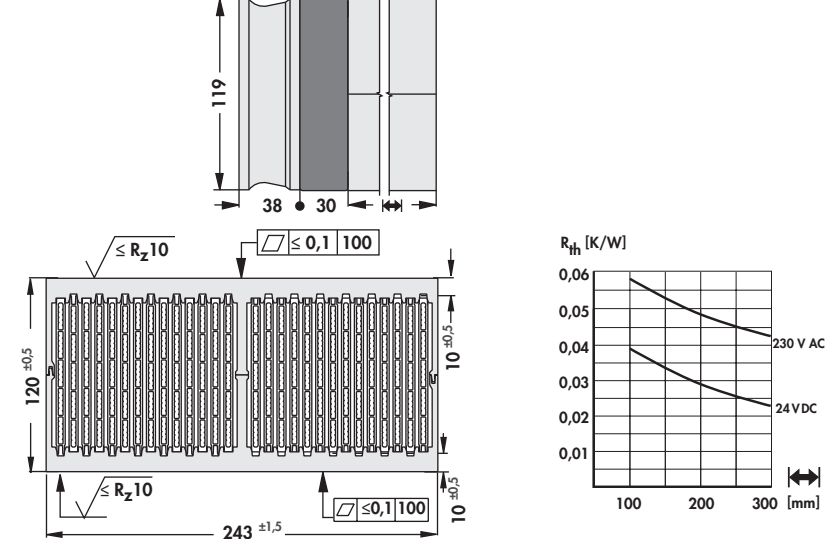



<p>art. no.</p>			
<p>LA V 17 ...</p>	<p>with air flow chamber</p>		
<p>art. no.</p>			
<p>LA V 18 ...</p>	<p>with air flow chamber</p>		
<p>please indicate: ... \longleftrightarrow 100 150 200 250 300 400 mm</p>			<p>... fan type 24 = 24 V DC 230 = 230 V AC</p>

Technical data of the fans

	... 24	... 230
type	ebmpapst 4184NXH	ebmpapst 4656N
dimensions	119x119x38 mm	119x119x38 mm
tension	24 V DC	230 V AC
power inout	11 W	19 W
max. air volume	237 m ³ /h	160 m ³ /h
temperature range	-30°C ... +70°C	-40°C... +85°C
noise level	57 dB(A)	47 dB(A)
speed	4,400 min ⁻¹	2,650 min ⁻¹
weight	390 g	550 g
failure rate (L ₁₀)	L ₁₀ > 70,000 h (40°C)	L ₁₀ > 37,500 h (40°C)

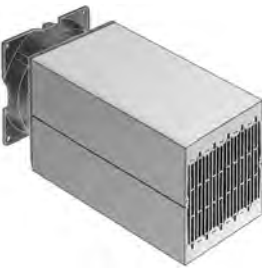
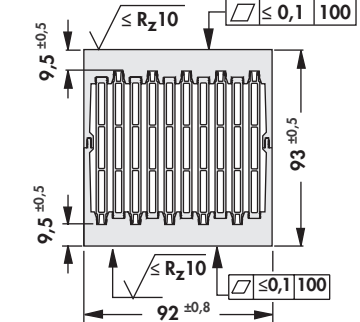
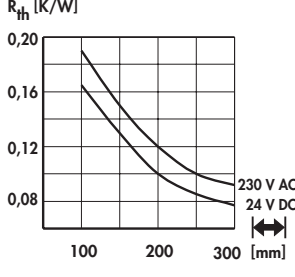
Hollow-fin cooling aggregates

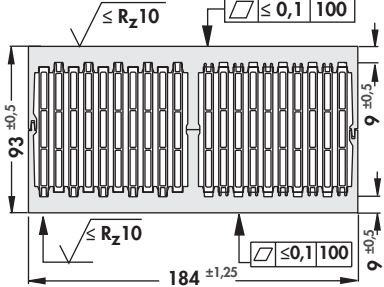
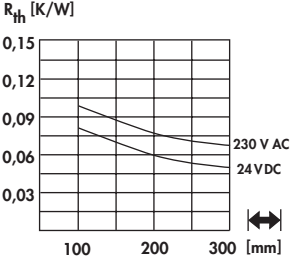
- extremely low losses due to optimised hollow fin geometry
- effective heat dissipation
- compact construction with axial fans
- two opposite mounting surfaces are milled flat
- additional treatment upon customer's request
- other fan types and fan voltages on request



art. no.			
LA 21 ...	without air flow chamber		
art. no.			
LA 22 ...	without air flow chamber		
please indicate: ...  100 150 200 250 300 400 mm ... fan type 24 = 24 V DC 230 = 230 V AC			

Technical data of the fans

	... 24	... 230
type	ebmpapst 3314 NHH	ebmpapst 3656
dimensions	92x92x32 mm	92x92x38 mm
tension	24 V DC	230 V AC
power inout	3.4 W	12 W
max. air volume	107 m ³ /h	75 m ³ /h
temperature range	-20°C... 75°C	-40°C... +75°C
noise level	42 dB(A)	37 dB(A)
speed	3,450 min ⁻¹	2,700 min ⁻¹
weight	190 g	420 g
failure rate (L₁₀)	L ₁₀ > 57,500 h (40°C)	L ₁₀ > 52,500 h (40°C)

Hollow-fin cooling aggregates

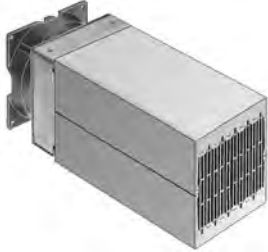
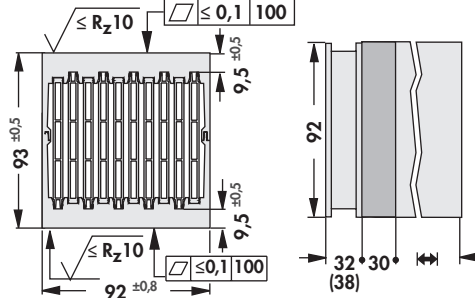
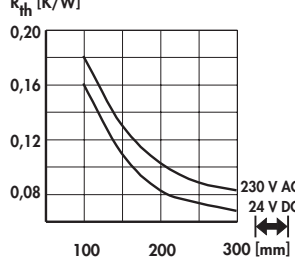
- extremely low losses due to optimised hollow fin geometry
- effective heat dissipation
- compact construction with axial fans
- two opposite mounting surfaces are milled flat
- additional treatment upon customer's request
- other fan types and fan voltages on request

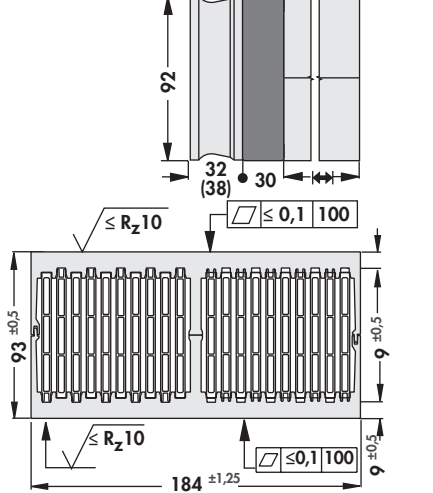
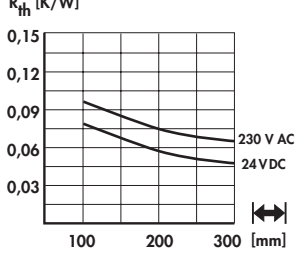
<p>art. no.</p>			
<p>LA V 21 ...</p>	<p>with air flow chamber</p>		
<p>art. no.</p>			
<p>LA V 22 ...</p>	<p>with air flow chamber</p>		
<p>please indicate: ... \longleftrightarrow 100 150 200 250 300 400 mm</p>		<p>... fan type 24 = 24 V DC 230 = 230 V AC</p>	

Technical data of the fans

	... 24	... 230
type	ebmpapst 3314 NHH	ebmpapst 3656
dimensions	92x92x32 mm	92x92x38 mm
tension	24 V DC	230 V AC
power inout	3.4 W	12 W
max. air volume	107 m ³ /h	75 m ³ /h
temperature range	-20°C... 75°C	-40°C... +75°C
noise level	42 dB(A)	37 dB(A)
speed	3,450 min ⁻¹	2,700 min ⁻¹
weight	190 g	420 g
failure rate (L ₁₀)	L ₁₀ > 57,500 h (40°C)	L ₁₀ > 52,500 h (40°C)

Hollow-fin cooling aggregates

- extremely low losses due optimised hollow fin geometry
- especially effective heat dissipation
- compact construction with axial fans
- two opposite mounting surfaces are milled flat
- additional treatment upon customer's request
- other fan types and fan voltages on request

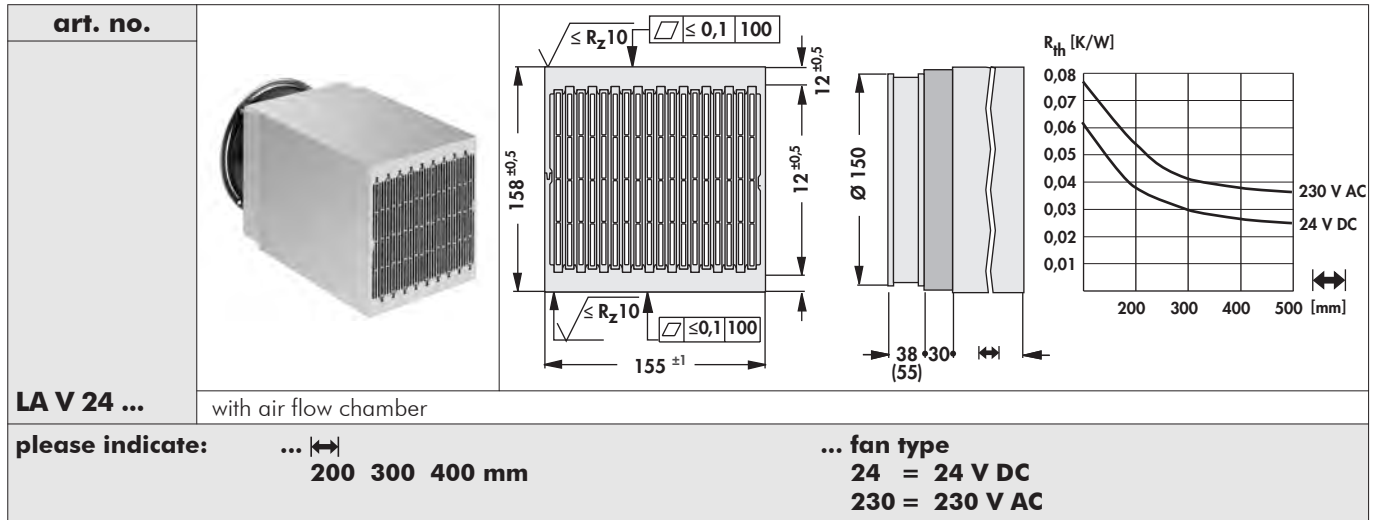

Technical data of the fans

	... 24	... 230
type	ebmpapst, ball bearing, with safety guard	ebmpapst, ball bearing, with safety guard
dimensions	Ø150x38 mm	Ø150x55 mm
tension	24 V DC	230 V AC
power in/out	19 W	47 W
max. air volume	366 m ³ /h	380 m ³ /h
temperature range	-25°C... +72°C	
noise level	58 dB(A)	60 dB(A)
speed	3,350 min ⁻¹	2,700 min ⁻¹
weight	620 g	1,100 g
failure rate (L₁₀)	L ₁₀ > 75,000 h (40°C)	L ₁₀ > 40,000 h (40°C)

High performance cooling aggregate

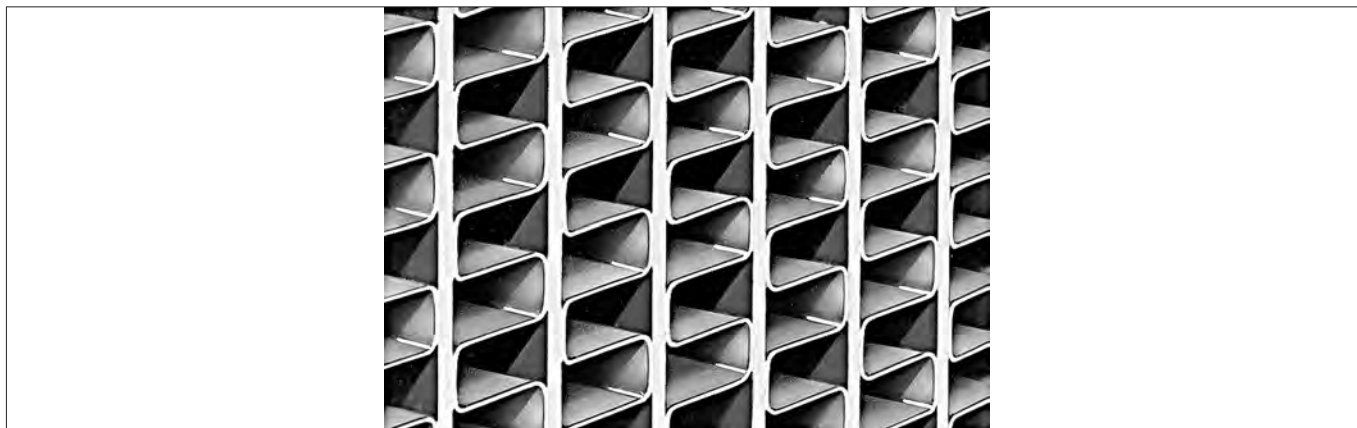

- extremely low losses of air flow as compared to cooling aggregates with extruded aluminium
- compact dimensions, that means high performance density due to large heat-conducting surfaces
- maximum heat flow due to brazing or thermal adhesion
- high performance cooling aggregates are only effective with forced ventilation by means of the fan, but not with free convection
- other fan types and fan voltages on request

material: solder-plated aluminium sheet, thus minimal weight due to the thickness of the material

An optimised unit for any application can be produced from the wide range of existing components upon request. The specific capacity will be determined by a test run upon customer's request.

Technical data of the fans

	... 230
type	ebmpapst 4656N
dimensions	119x119x38 mm
tension	230 V AC
power inout	19 W
max. air volume	160 m ³ /h
temperature range	-40°C... +85°C
noise level	47 dB(A)
speed	2,650 min ⁻¹
weight	550 g
failure rate (L₁₀)	L ₁₀ > 37,500 h (40°C)

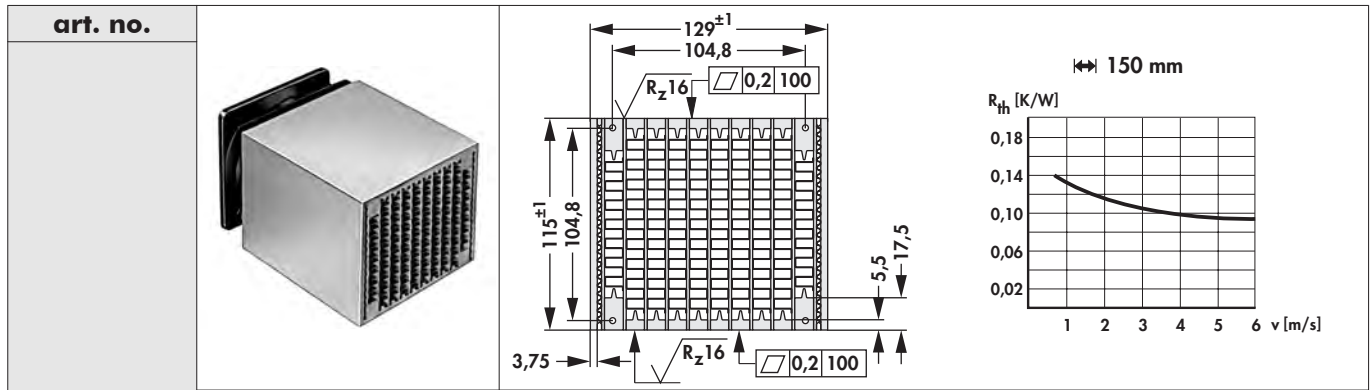
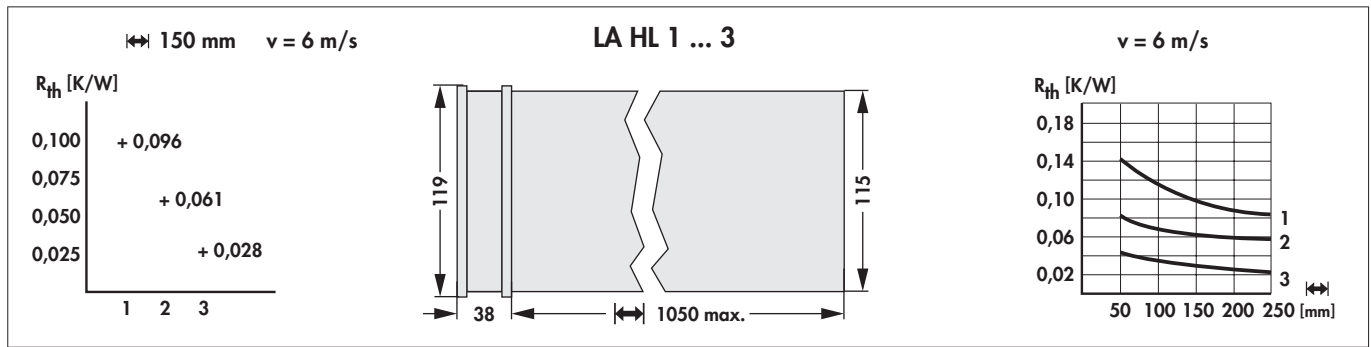
High performance cooling aggregate

LA HL 1 ...

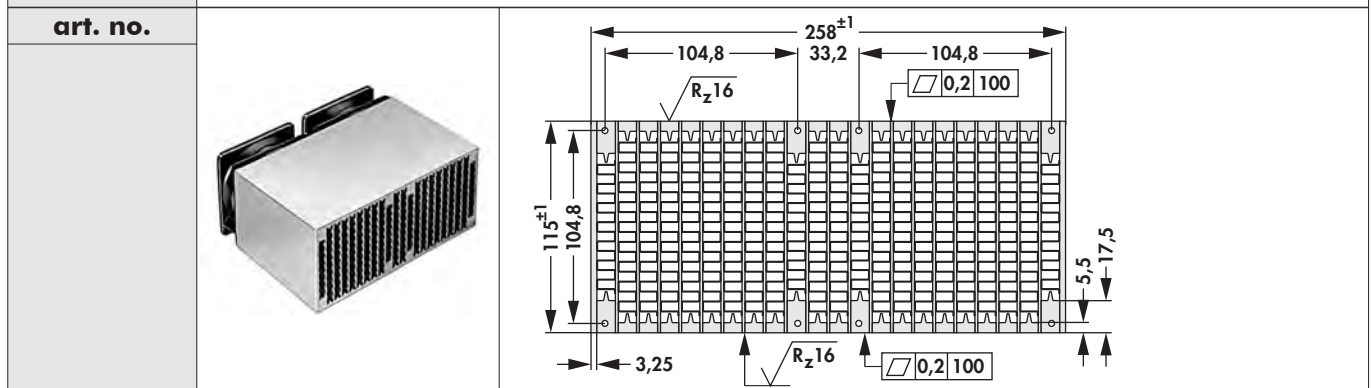
without air flow chamber

LA HL 2 ...

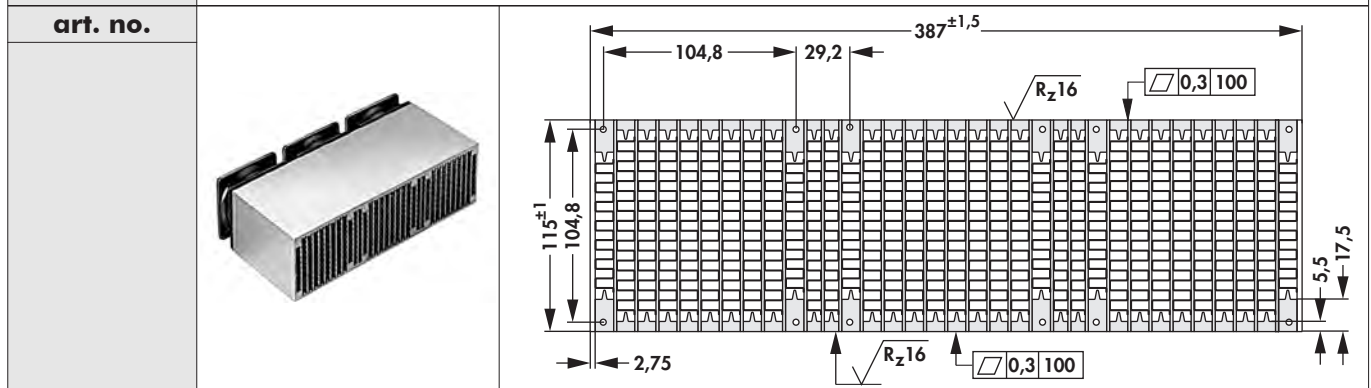
without air flow chamber



LA HL 3 ...



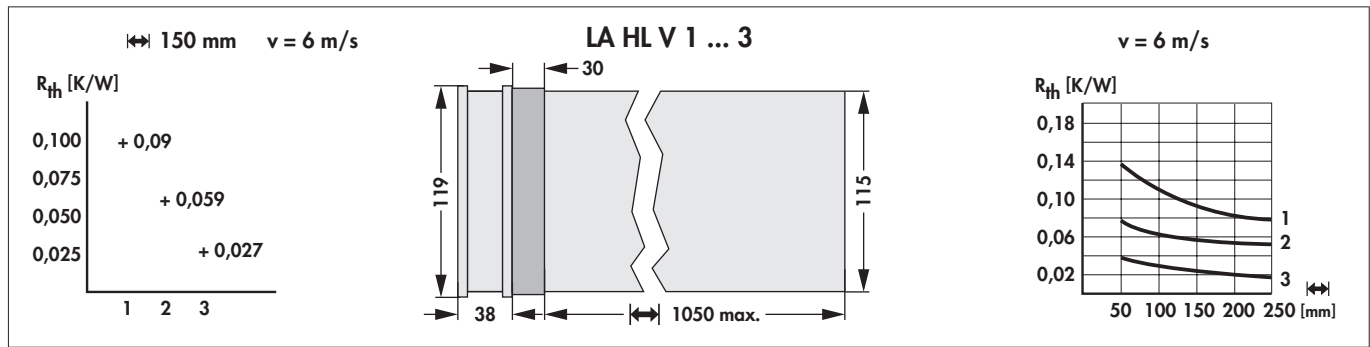

without air flow chamber

please indicate:



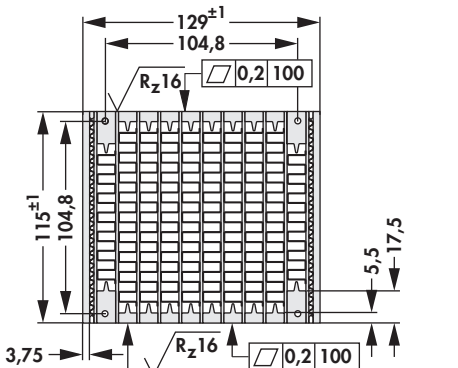

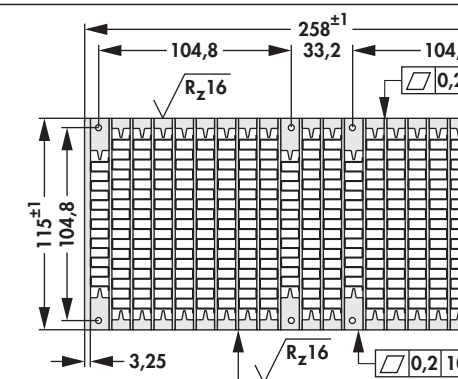
 ... \leftrightarrow
 100 150 200 250 300 400 mm

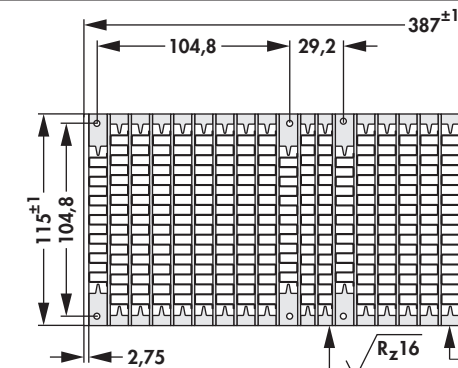
High performance cooling aggregate

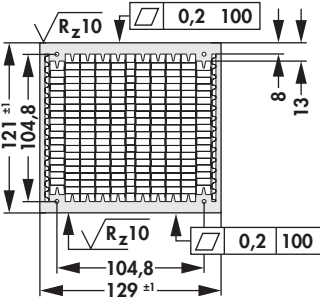
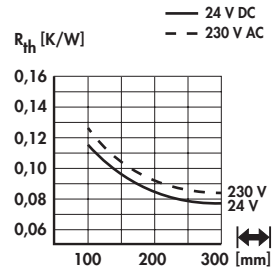

<p>art. no.</p>			<p>$v = 6 \text{ m/s}$</p> <p>$R_{th} \text{ [K/W]}$</p> <table border="1"> <tr><td>1</td><td>0,14</td></tr> <tr><td>2</td><td>0,10</td></tr> <tr><td>3</td><td>0,07</td></tr> <tr><td>4</td><td>0,06</td></tr> <tr><td>5</td><td>0,05</td></tr> <tr><td>6</td><td>0,04</td></tr> </table> <p>150 mm</p>	1	0,14	2	0,10	3	0,07	4	0,06	5	0,05	6	0,04
1	0,14														
2	0,10														
3	0,07														
4	0,06														
5	0,05														
6	0,04														
<p>LA HLV 1 ...</p> <p>with air flow chamber</p>															
<p>LA HLV 2 ...</p> <p>with air flow chamber</p>															
<p>LA HLV 3 ...</p> <p>with air flow chamber</p>	<p>please indicate: ... \leftrightarrow 100 150 200 250 300 400 mm</p>														

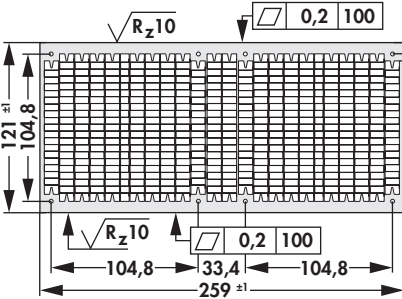
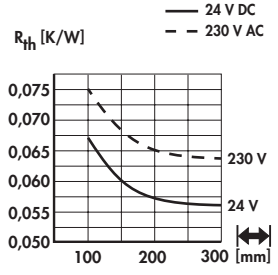

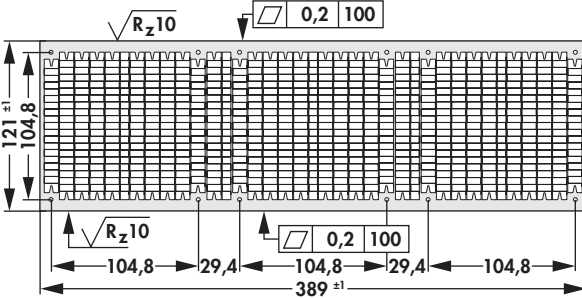
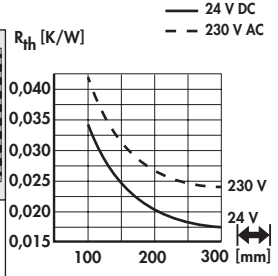



- extremely low losses of air flow as compared to cooling aggregates with extruded aluminium
- compact dimensions, that means high performance density due to large heat-conducting surfaces
- maximum heat flow due to brazing or thermal adhesion
- high performance cooling aggregates are only effective with forced ventilation by means of the fan, but not with free convection
- other fan types and fan voltages on request

art. no.			
LA HB 1 ...	without air flow chamber		
art. no.			
LA HB 2 ...	without air flow chamber		
art. no.			
LA HB 3 ...	without air flow chamber		
please indicate:	... 100 150 200 250 300 mm		... fan type 24 = 24 V DC 230 = 230 V AC

Technical data of the fans

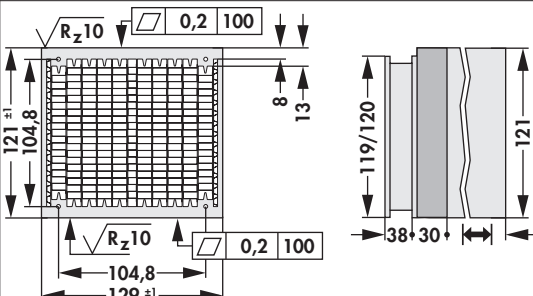
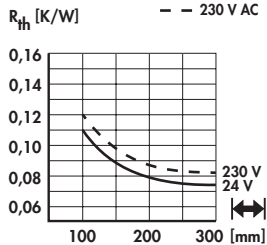
	... 24	... 230
type	ADDA A1224MB	ebmpapst 4656N
dimensions	120x120x38.5 mm	119x119x38 mm
tension	24 V DC	230 V AC
power inout	16.32 W	19 W
max. air volume	276 m ³ /h	160 m ³ /h
temperature range	-10°C... +70°C	-40°C... +85°C
noise level	73.1 dB(A)	47 dB(A)
speed	3.800 min ⁻¹	2,650 min ⁻¹
weight	335 g	550 g
failure rate (L₁₀)	70.000 h (40°C)	L ₁₀ > 37,500 h (40°C)

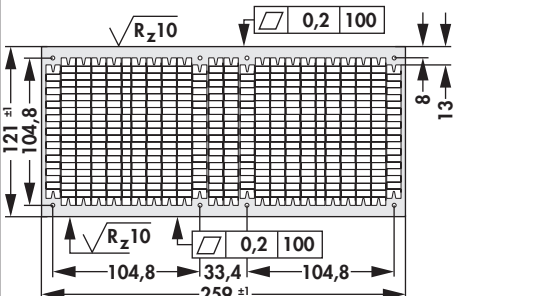
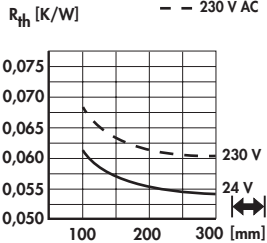
- extremely low losses of air flow as compared to cooling aggregates with extruded aluminium
- compact dimensions, that means high performance density due to large heat-conducting surfaces
- maximum heat flow due to brazing or thermal adhesion
- high performance cooling aggregates are only effective with forced ventilation by means of the fan, but not with free convection
- other fan types and fan voltages on request

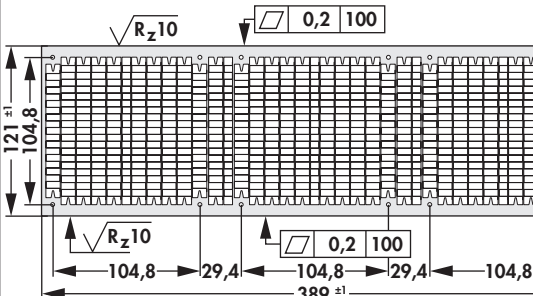
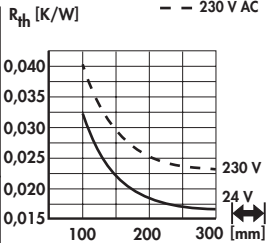
art. no. 			
LA V HB 1 ... with air flow chamber			
art. no. 			
LA V HB 2 ... with air flow chamber			
art. no. 			
LA V HB 3 ... with air flow chamber			
<p>please indicate: ... \longleftrightarrow 100 150 200 250 300 mm ... fan type 24 = 24 V DC 230 = 230 V AC</p>			

Technical data of the fans

	... 24	... 230
type	ADDA A1224MB	ebmpapst 4656N
dimensions	120x120x38.5 mm	119x119x38 mm
tension	24 V DC	230 V AC
power inout	16.32 W	19 W
max. air volume	276 m ³ /h	160 m ³ /h
temperature range	-10°C... +70°C	-40°C... +85°C
noise level	73.1 dB(A)	47 dB(A)
speed	3.800 min ⁻¹	2,650 min ⁻¹
weight	335 g	550 g
failure rate (L₁₀)	70.000 h (40°C)	L ₁₀ > 37,500 h (40°C)

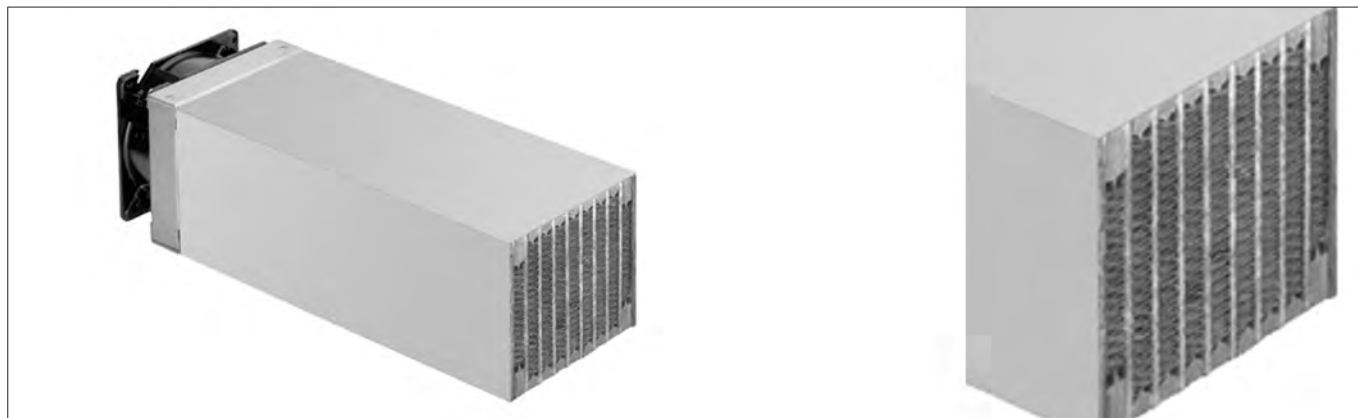

High performance cooling aggregate

- innovative, efficient heatsink design
- thick multiwall sheets for maximum heat dissipation
- specially formed laminated structures ensure optimum heat exchange with the air flow
- powerful mixed axial fan for highly efficient heat dissipation
- reduced noise output achieved by an optimised adaption of fan and heatsink
- additional treatment and modifications upon customer's request
- double and triple versions upon request

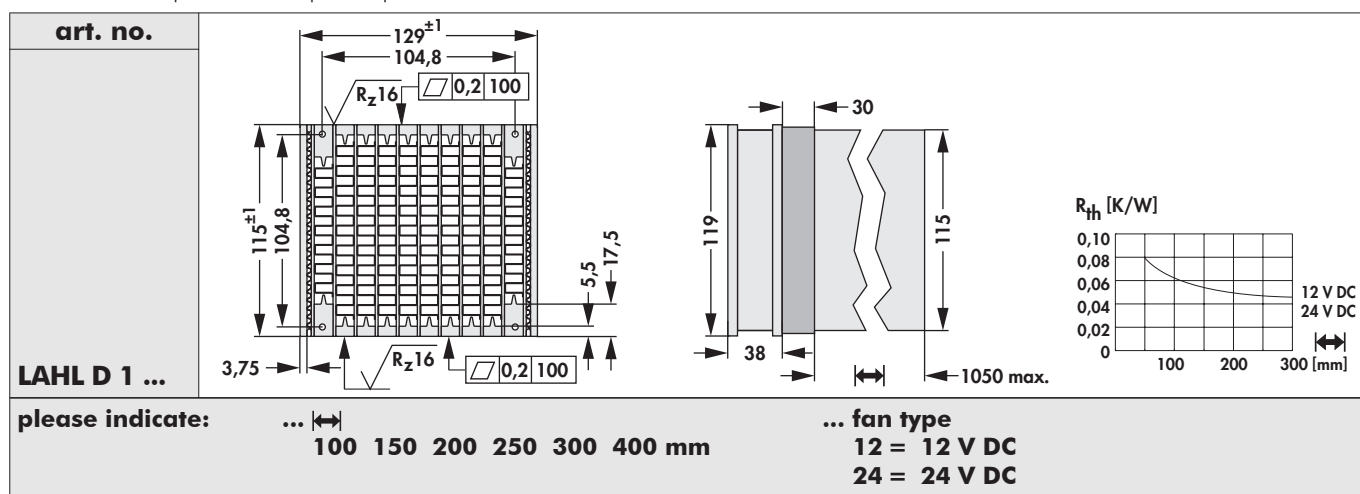

Technical data of the fans

	... 12	... 24
type	ebmpapst 4112NH3	ebmpapst 4114NH3
dimensions	119x119x38 mm	119x119x38 mm
tension	12 V DC	24 V DC
power inout	21.6 W	19.5 W
max. air volume	310 m ³ /h	310 m ³ /h
temperature range	-20°C... +65°C	-20°C... +65°C
noise level	65 dB(A)	65 dB(A)
speed	6,000 min ⁻¹	6,000 min ⁻¹
weight	390 g	390 g
failure rate (L₁₀)	L ₁₀ > 60,000 h (40°C) L ₁₀ > 37,500 h (tmax)	L ₁₀ > 65,000 h (40°C) L ₁₀ > 37,500 h (tmax)

High performance heatsinks with hollow-fin profile

- high performance heatsinks for fan operation
- exclusively for forced convection
- preferably for radial or tangential fans
- hollow fin geometry optimises the air flow
- particularly effective heat dissipation
- milled flat base (except length 1000 mm)

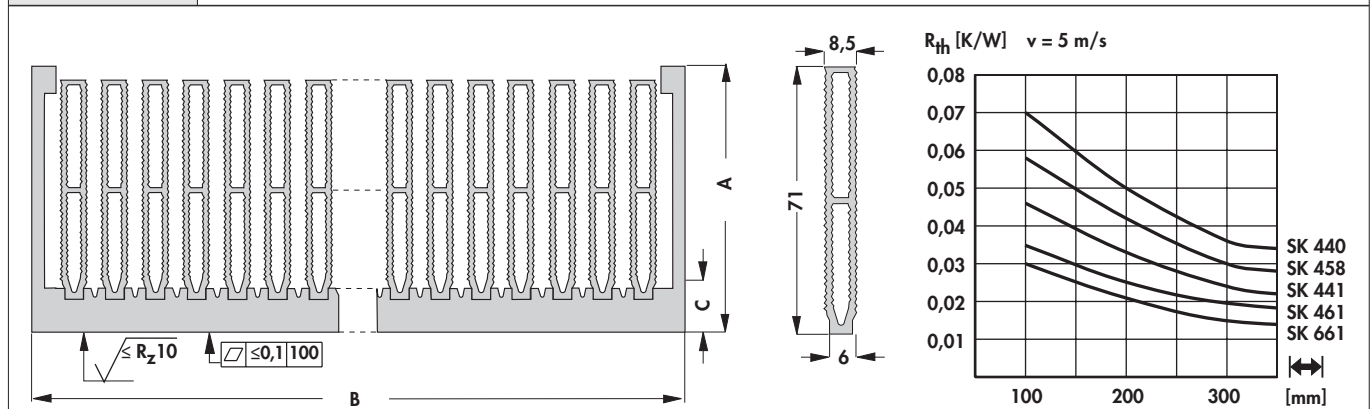
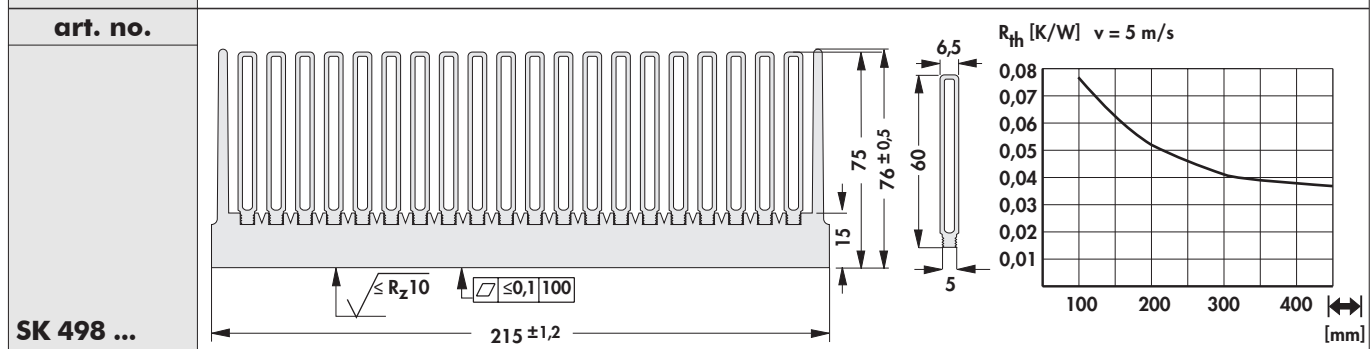
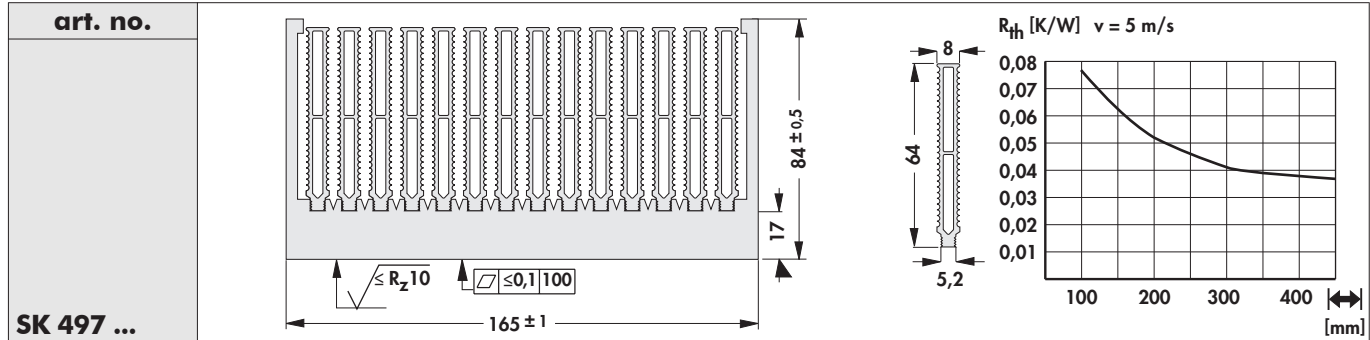





art. no.	number of fins	dim. [mm]		
		A	B	C
SK 440 ...	15	84 ± 1	200 ± 1.2	16
SK 458 ...	19		250 ± 1.4	
SK 441 ...	23		300 ± 1.6	
SK 461 ...	31	88 ± 1	400 ± 2.0	20
SK 661 ...	48	84 ± 1	500 ± 2.5	19

please indicate: ... \longleftrightarrow 150 200 250 300 1000 mm

... surface
SA = black anodised
AL = aluminium natural/degreased/
cutting edges not deburred (by the
metre not degreased/cutting
edges not deburred)

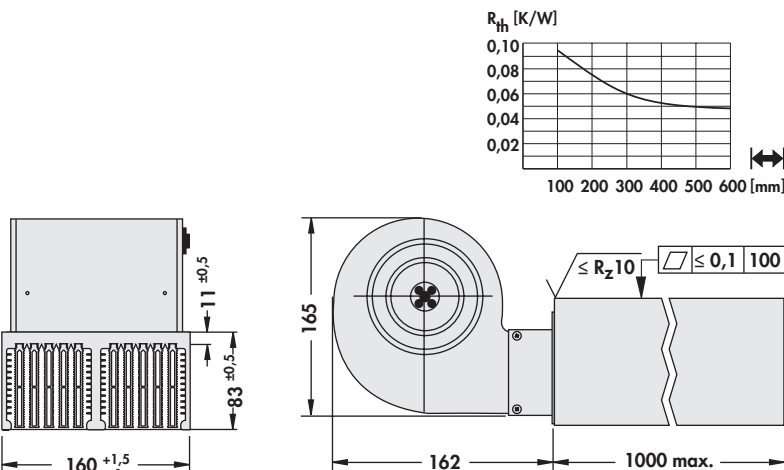
High performance cooling aggregate

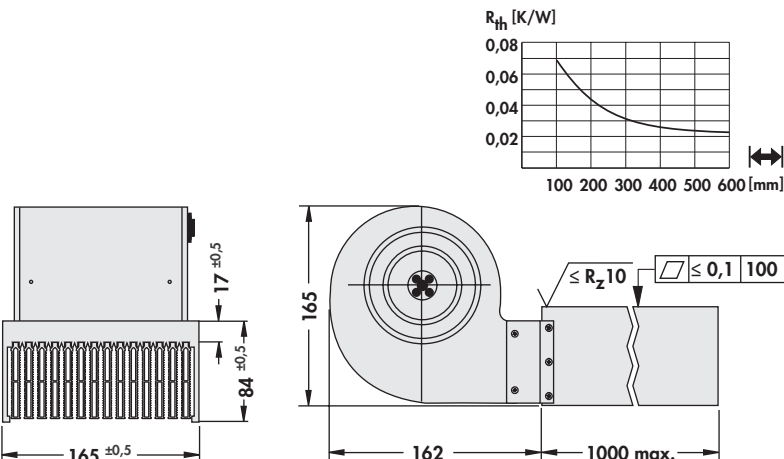
- optimised air flow due to hollow fin geometrie
- very good thermal performance
- optimized high performance construction with radial fan
- milled flat mounting surface for semiconductor
- cover plate for fin side upon request
- additional customized treatment upon request
- fan condenser: **art. no. LAHLR K 2**



art. no. LA 25 ...		
art. no. LA 26 ...		
please indicate: ...  200 300 400 500 600 mm		

Technical data of the fans

	... 230
type	ebmpapst, radial blower with safety guard, double sided absorption
bearing type	ball bearing
discharge air flow	435 m ³ /h
rotation speed	1,950 min ⁻¹
power inout	87 W
current consumption	0.39 A
temperature range	-25°C... +40°C
circuit voltage	230 V AC
motor condenser	2 µF/400 V
noise level	58 dB(A)
weight	1,500 g

High performance cooling aggregate

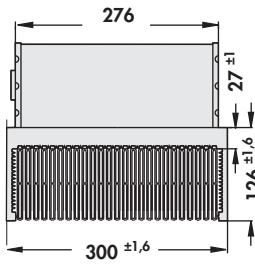
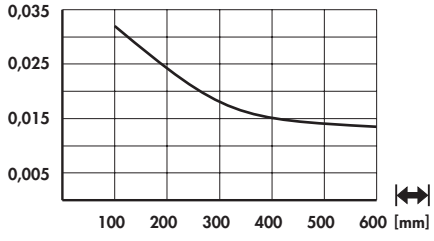
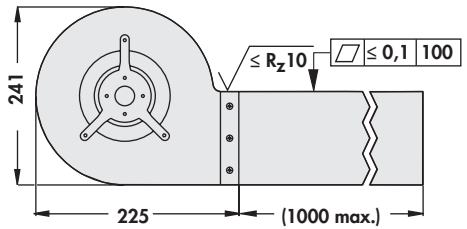
- optimised air flow due to hollow fin geometrie
- very good thermal performance
- optimized high performance construction with radial fan
- milled flat mounting surface for semiconductor
- cover plate for fin side upon request
- additional customized treatment upon request
- fan condenser: **art. no. LA 20 K 6**

art. no.			<p>R_{th} [K/W]</p> 
LA 20 ...			
please indicate:	 ... 200 300 400 500 600 mm		

Technical data of the fans

	... 230
bearing type	ball bearing
type	ebmpapst, radial blower with safety guard, double sided absorption
discharge air flow	1,310 m ³ /h
rotation speed	1,350 min ⁻¹
power inout	185 W
current consumption	0.81 A
circuit voltage	230 V AC
temperature range	-25°C... +70°C
motor condenser	6 μF
noise level	64 dB(A)
weight	5,900 g

Safety guard for fans

- protection against contact as per EN 294
- aerodynamic construction
- minimized noise modification
- only low modification of the air flow

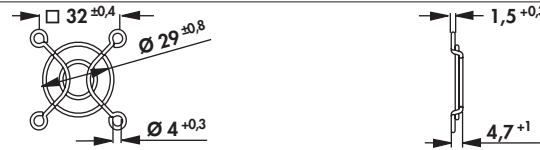
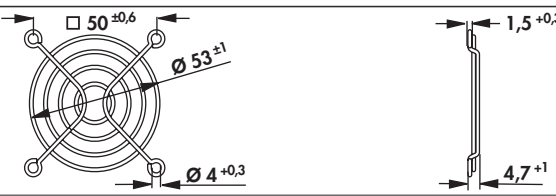
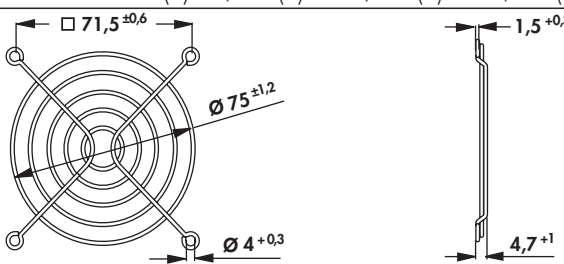
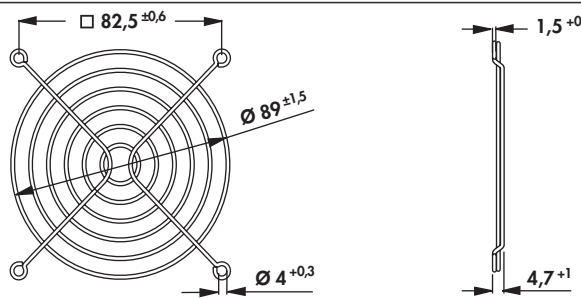
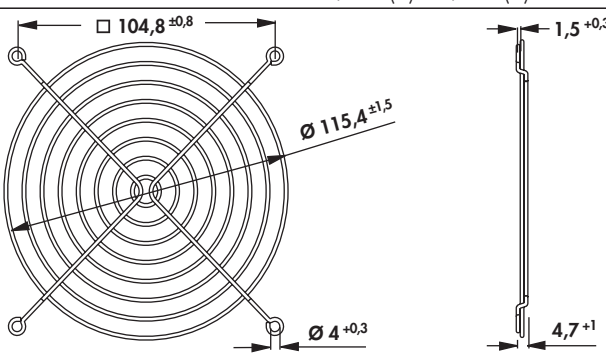
	
art. no.	suitable for cooling aggregate
LAGI 40	LAM 2/ LAM 2 S/ LAM 4/ LAM 4 D/ LAM 4 K/ LAM 4 DK
	
art. no.	suitable for cooling aggregate
LAGI 60	LAM 1/ LAM 6/ LAM 6 K/ LAM 6 D/ LAM 6 D K/ LA (V) 6/ LA (V) 7/ LA (V) 8/ LA 27 K/ LA (V) 28/ LA (V) 29/ LA (V) 30/ LA (V) HB 4/ LA (V) HB 5/ LA (V) HB 6
	
art. no.	suitable for cooling aggregate
LAGI 80	LA (V) 9/ LA (V) 10/ LA (V) 11/ LA (V) 31/ LA (V) 32/ LA (V) 33/ LA (V) 34/ LA (V) 35/ LA (V) HB 7/ LA (V) HB 8/ LA (V) HB 9
	
art. no.	suitable for cooling aggregate
LAGI 92	LA 2/ LA (V) 21/ LA (V) 22
	
art. no.	suitable for cooling aggregate
LAGI 119	LA 1/ LA 4/ LA 5/ LA (V) 14/ LA (V) 15/ LA (V) 17/ LA (V) 18/ LA HL (V) 1/ LA HL (V) 2/ LA HL (V) 3 / LA HL D1/ LA (V) HB 1/ LA (V) HB 2/ LA (V) HB 3
material:	steel wire, nickel-plated

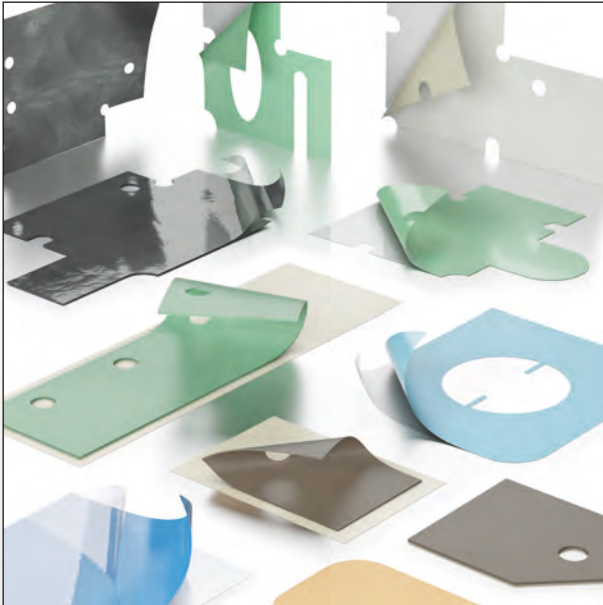

Thermally conductive film

- extensive standard programme of heat conducting foils, cut-to-size sheets, tapes, caps and tubes
- silicone-free and silicone-containing heat conducting foils
- electrically insulating or conductive
- single-sided or double-sided adhesive designs
- 24-hour sample delivery service for customised cuts and geometries of our heat conducting films in our in-house punching shop

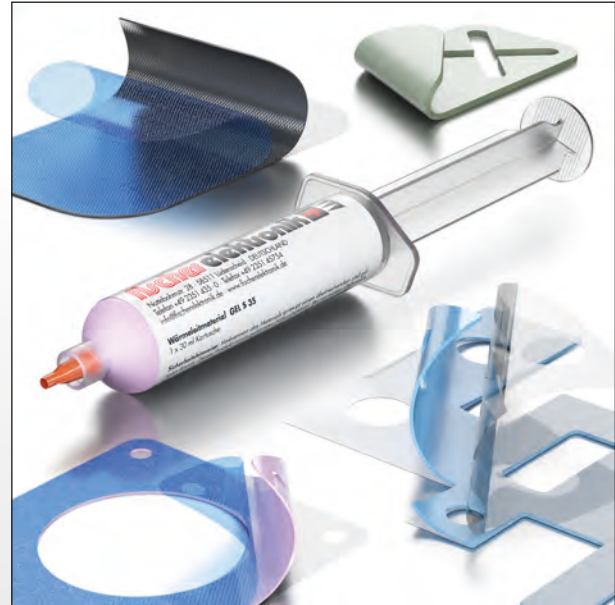

Gel heat conducting materials

- silicone-contain. and silicone-free gel heat conduct. foils
- soft, elastic and compressible
- optimum levelling of unevennesses and component differences; • with and without adhesive coating
- also available as a one- or two-component liquid material, automatically dispensable
- customised contour parts according to drawing specifications



Thermally conductive pastes

- silicone-free and silicone-containing thermal conductive pastes
- very good thermal properties with high long-term stability
- different fillers and thermal conductivities
- no drying out, hardening or melting
- filled in syringes, cans and cartridges
- other container sizes and types on request



Thermally conductive adhesives

- solvent-free and thermally conductive two-component adhesives
- very good thermal conductivity
- complete replacement of mechanical connections
- mixture of hardener and binder (1:1) with static mixing tube
- good usage and processing properties
- store in a cool and dark place

The connection of the device to be dissipated to the heat sink is especially important as for a poor heat transfer, i.e. from the device to the heatsink, the heat conduction respectively the heat transition is reduced and the device temperature will be significantly increased. Beside functional restrictions an uncontrolled temperature increase or even a device destruction is also possible. An optimal heat transfer can only be achieved if the inevitable tolerances, unevennesses and roughnesses of the surfaces to be connected which occur by production processes will be equalised. Suitable thermal conductive foils matching to the application provide excellent solutions for the thermotechnical contact optimization.

Our wide range of products contains i.e. silicon-containing and silicone-free thermal conductive foils, one sided and double sided adhesive thermal conductive foils, high thermal conductive graphite foils, thermal conductive silicone foam foils, silicone-containing and silicone-free GEL thermal conductive foils, dispensable GEL thermal conductive foils, kapton insulating washers, aluminium oxide and mica washers, phase change thermal conductive materials, silicone-containing and silicone-free thermal conductive pastes as well as various thermal conductive glues.

The different thermal conductive foils can be produced individually out of plate- or roll material according to customer specific drawings. Please also use our **24 hour sample service** for individual cuts of our standard thermal conductive materials according to your specification.

Production process:

Drawing parts with digital cutter



CAD data as a dxf file can be realised directly in ready and zero-toleranced exact cut templates without tooling costs. The outstanding production speed and a cutting technology perfected to the last detail provide an optimal result.

Stamped parts according to customer specific requirements

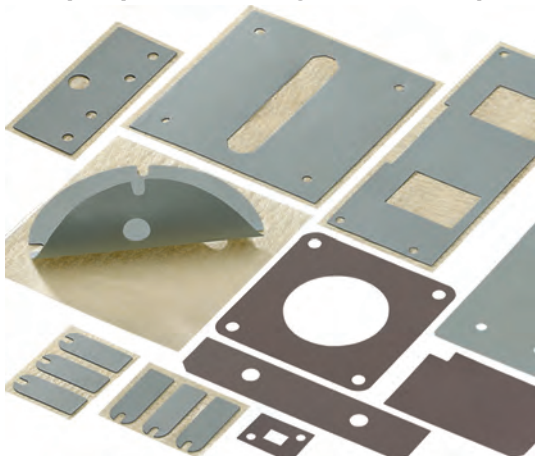

We produce contour die-cutting according to your drawing specification flexibly and fast for you.

The fully automatised punching machine with the associated steel strip blanking die is particularly suitable for smaller, but also for higher quantities. Beside contour- and kiss-cut parts the possibility of cutting roll material to size or machining according to customer's requirements is also given.

The thermal data in the catalogue refers to an area of 1 inch² (6.45 cm²) if not indicated otherwise.

Overview thermal interface material

art. no.	thermal conductivity [W/m*K]	material thickness [mm]	page
WLFT 404 ... / WLFT 414 ... (double sided)	0.400	0.127	E 39
WLFT 405 ... (double sided)	0.500	0.15	E 39
WSF(S) ...	0.460 @ 1.6 mm 0.520 @ 3.2 mm	0.8 / 1.6 / 2.4 / 3.2 / 4.8 / 6.35	E 43
WLFT 88 ... (double sided)	0.600	0.13 / 0.25 / 0.38 / 0.5	E 41
WLP ...	0.610	-	E 79
WLPF 07 ...	0.700	-	E 80
WLK ...	0.836	-	E 83
WFPK 09	0.900	0.152	E 28
WFS 09 ...	0.900	0.178 / 0.229	E 16
WG ...	0.900	0.2	E 14
WK ... (adhesive on one side)	0.900	0.2	E 14
WFP 09	0.900	0.229	E 29
WLK DK ...	1.000	-	E 84
WS ...	1.200	0.3	E 14
WFPK 13	1.300	0.152	E 30
WLPF 13 ...	1.300	-	E 81
WLFT 412 ... (double sided)	1.400	0.23	E 39
GEL 14 (G) ...	1.400	0.5 / 1.0 / 1.5 / 2.0 / 2.5 / 3.0 / 3.5 / 4.0 / 4.5 / 5.0	E 47
WB ...	1.440	0.15	E 14
FSF 15 P ...	1.500	0.114 / 0.127 / 0.140	E 75
WLFT 8926 ... (double sided)	1.500	0.2 / 0.25 / 0.5	E 42
WFG 15 ...	1.500	0.508 / 1.016 / 1.524 / 2.032 / 2.54 / 3.175 / 4.064 / 5.08	E 48
GEL F 15 (G) ...	1.500	1.0 / 1.5 / 2.0	E 44
FSF 16 P ...	1.600	0.102 / 0.114 / 0.127	E 76
WFS 16	1.600	0.229	E 17
WFKF 18 ...	1.800	0.150 / 0.175 / 0.325	E 31
WFS 18	1.800	0.203	E 18
WFK 18 ...	1.800	0.225 / 0.25	E 19
GEL S 18 (liquid)	1.800	-	E 68
GEL S 20 (liquid)	1.800	-	E 69
FSF 20 P	2.000	0.200	E 77
GEL F 20 ...	2.000	0.5 / 1.0	E 45
WLK SK 50	2.000	-	E 85
WLPF 23 ...	2.300	-	E 81
WFQ 25	2.500	0.152	E 34
WFK 25 ...	2.500	0.225 / 0.25	E 20
GEL 28 (G) ...	2.500	0.5 / 1.0 / 1.5 / 2.0 / 2.5 / 3.0 / 3.5 / 4.0 / 4.5 / 5.0	E 49
GEL 28 S ...	2.500	1.0 / 1.5 / 2.0 / 2.5 / 3.0 / 3.5 / 4.0 / 4.5 / 5.0	E 60
FSF 30 P	3.000	0.12	E 77
WLFT 30 ... (one-sided)	3.000	0.15 / 0.23	E 37

Explanation of the colours:

Thermally conductive foils containing silicone	Silicone-free thermally conductive foils	Aluminium and graphite foils	Adhesive thermally conductive foils	GAP Filler thermally conductive foils	GAP Fillers for extreme compressions	PhaseChange thermally conductive foils	Thermally conductive pastes	Thermally conductive glues
--	--	------------------------------	-------------------------------------	---------------------------------------	--------------------------------------	--	-----------------------------	----------------------------

art. no.	thermal conductivity [W/m*K]	material thickness [mm]	page
WFKF 30 02	3.000	0.2	E 32
WFP 30 ...	3.000	0.2 / 0.3 / 0.45	E 21
WFS 30 ...	3.000	0.508	E 22
GEL F 30 ...	3.000	0.5 / 1.0 / 1.5	E 46
WFGH 30 ...	3.000	0.508 / 1.016 / 1.524 / 2.032 / 2.54 / 3.175	E 50
GEL 30 S ...	3.000	0.5 / 1.0 / 1.5 / 2.0 / 2.5 / 3.0 / 3.5 / 4.0	E 61
GEL S 30 (liquid)	3.000	-	E 69
GEL 32 A ...	3.200	0.5 / 1.0 / 1.5 / 2.0 / 2.5 / 3.0	E 51
WLPF 33 ...	3.300	-	E 82
WFS 34 ...	3.400	0.2 / 0.3 / 0.45	E 23
WFK 35 ...	3.500	0.125 / 0.225 / 0.25	E 24
GEL S 35 ... (liquid)	3.500	-	E 70
WLFT 40 023 (one-sided)	4.000	0.23	E 38
GEL S 40 (liquid)	4.300	-	E 69
GEL 45 (G) ...	4.500	0.5 / 1.0 / 1.5 / 2.0 / 2.5 / 3.0 / 3.5 / 4.0 / 4.5 / 5.0	E 52
GEL 45 S ...	4.500	1.5 / 2.0 / 2.5	E 62
WFC 50 ...	5.000	0.2 / 0.3 / 0.45 / 0.8	E 25
WFGH 50 ...	5.000	0.508 / 1.016 / 1.524 / 2.032 / 2.54 / 3.175	E 53
GEL 50 S ...	5.000	0.5 / 1.0 / 1.5 / 2.0 / 2.5 / 3.0 / 3.5 / 4.0	E 63
FSF 50 P ...	5.300	0.125 / 0.200 / 0.250	E 78
WFK 60 ...	6.000	0.1 / 0.2 / 0.225 / 0.3	E 33
GEL 60 (G) ...	6.000	0.5 / 1.0 / 1.5 / 2.0 / 2.5	E 54
GEL 60 A ...	6.000	0.5 / 1.0 / 1.5 / 2.0 / 2.5 / 3.0	E 55
WFK 65 ...	6.500	0.25 / 0.275	E 26
GEL 65 S ...	6.500	0.5 / 1.0 / 1.5 / 2.0	E 64
GEL 70 S ...	7.000	1.0 / 1.5 / 2.0 / 2.5 / 3.0 / 3.5 / 4.0	E 65
WFLG S 900 ...	7.500	0.15	E 35
WFLG 98 ...	8.000	0.13 / 0.25 / 0.5	E 36
WFS 80 ...	8.000	0.2 / 0.3 / 0.45	E 27
GEL 80 (G) ...	8.000	0.3 / 0.5 / 1.0 / 1.5 / 2.0 / 2.5 / 3.0	E 56
GEL 80 S ...	8.000	0.5 / 1.0 / 1.5 / 2.0	E 66
GEL 83 A ...	8.300	0.5 / 1.0 / 1.5 / 2.0 / 2.5 / 3.0	E 57
GEL 100 (G) ...	10.000	0.3 / 0.5 / 1.0 / 1.5 / 2.0	E 58
WLPK ...	10.000	-	E 82
GEL 130 ...	13.000	0.3 / 0.5 / 1.0 / 1.5 / 2.0	E 59
GEL 130 S ...	13.000	0.3 / 0.5 / 1.0 / 1.5 / 2.0	E 67

Explanation of the colours:

Thermally conductive foils containing silicone	Silicone-free thermally conductive foils	Aluminium and graphite foils	Adhesive thermally conductive foils	GAP Filler thermally conductive foils	GAP Fillers for extreme compressions	PhaseChange thermally conductive foils	Thermally conductive pastes	Thermally conductive glues
--	--	------------------------------	-------------------------------------	---------------------------------------	--------------------------------------	--	-----------------------------	----------------------------

Thermal conductive foils for semiconductors



- thermal conductive foils cut to size for IGBT, DC/DC converters and Solid State Relais
- other thermal conductive materials and cuts according to customer's specifications

art. no.	page	thermal conductivity [W/m·k]	material thickness [mm] [mm]	type
WFQ 25	E 34	2,5	0,152	aluminium foil
WLFG S 900	E 35	7,5	0,150	graphite foil
WLFG 9813	E 36	8,0	0,130	
WLFG 9825	E 36	8,0	0,250	
WLFG 9850	E 36	8,0	0,500	
FSF 15 P 011	E 75	1,5	0,114	phase-change thermal conductive foil
FSF 15 P 012	E 75	1,5	0,127	
FSF 15 P 014	E 75	1,5	0,140	
FSF 20 P	E 77	2,0	0,200	

Order example

WLFG 9813 Thermally conductive foil	54 x 94 dimension
--	----------------------------------

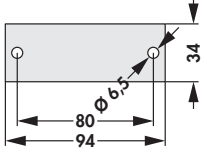
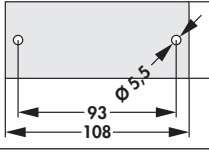
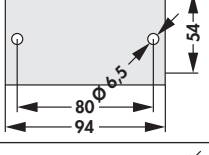
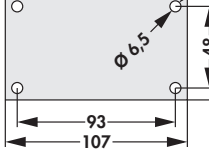
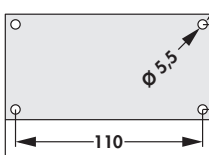
IGBT

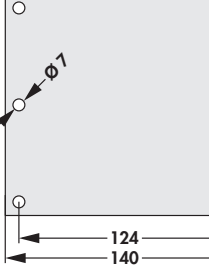
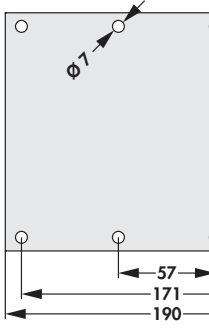
dimension [mm]	blanks	manufacturer	component
34 x 94		Infineon MCC IXYS Semikron	Int-A-Pak (New) / 34mm Module MF ... F2 / MT ... T2 / MD ... D2 Y4-M6 SEMISTRANS 2 / SEMIPACK 2
45 x 108		Infineon IXYS	Econo 2 / Econo PIM 2 / Econo PACK 2 / Econo BRIDGE / Iso PACK 2 E2-Pack
54 x 94		Infineon MCC IXYS Semikron	MTC / Iso PACK 54 MD ... M3 / MD ... M5 PWS-E Flat / PWS-E SEMIPOINT 4
62 x 107		Infineon MCC IXYS Semikron	Dual Int-A-Pak / 62 mm Module MT ... L2 E3-Pack SEMISTRANS 3 / SEMISTRANS 4
62 x 122		Infineon IXYS Semikron	Econo 3 / Econo DUAL + / Econo PIM 3 / Econo PACK 3 SimBus F SEMIX 3p / SEMIX 3lp
73 x 140		Infineon	IHV
130 x 140		Infineon	IHM / IHV
140 x 190		Infineon	IHM / IHV

DC/DC converter

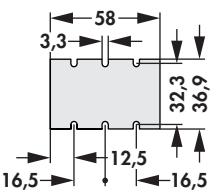
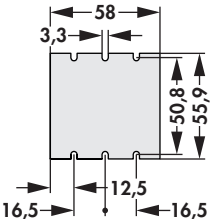
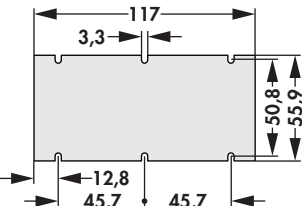
dimension [mm]	blanks	component
36.9 x 58		Micro DC/DC-converter
55.9 x 58		Mini DC/DC-converter
55.9 x 117		Maxi DC/DC-converter

Solid State Relais

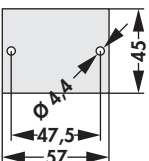
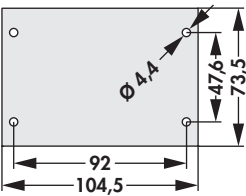
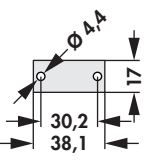
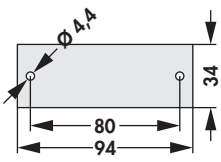
dimension [mm]	blanks	component
45 x 57		SSR 1
73.5 x 104.5		SSR 2
17 x 38.1		SSR 3
34 x 94		SSR 4





Thermal conductive foils for LED

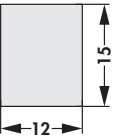
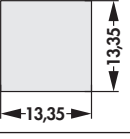
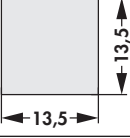
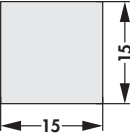

- thermal conductive foils cut to size for LEDs
- other thermal conductive materials and cuts according to customer's specifications

art. no.	Seite	thermal conductivity [W/m·k]	material thickness [mm]	type
WFQ 25	E 34	2,5	0,152	aluminium foil
WLFG S 900	E 35	7,5	0,150	graphite foil
WLFG 9813	E 36	8,0	0,130	
WLFG 9825	E 36	8,0	0,250	
WLFG 9850	E 36	8,0	0,500	
WLFT 404	E 39	0,4	0,127	double-sided adhesive thermal conductive foil
WLFT 405	E 39	0,5	0,150	
WLFT 8805	E 41	0,6	0,130	
WLFT 8810	E 41	0,6	0,250	
WLFT 8815	E 41	0,6	0,380	
WLFT 8820	E 41	0,6	0,500	
WLFT 8926	E 42	1,5	0,2 / 0,25 / 0,5	
WLFT 30	E 37	3,0	0,15 / 0,23	
FSF 15 P 011	E 75	1,5	0,114	phase-change thermal conductive foil
FSF 15 P 012	E 75	1,5	0,127	
FSF 15 P 014	E 75	1,5	0,140	
FSF 20 P	E 77	2,0	0,200	

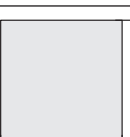
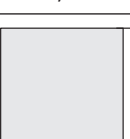
Order example

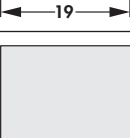
WLFT 8810 Thermally conductive foil	20 x 24 dimension
--	----------------------------------

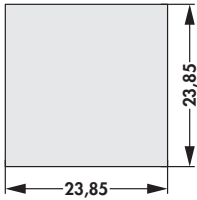
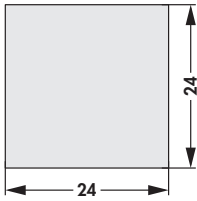
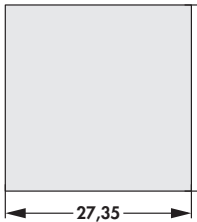

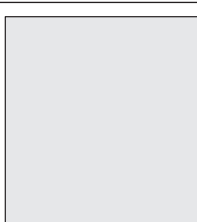
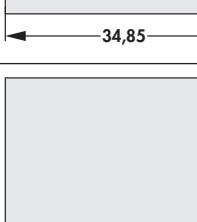
dimension [mm]	blanks	manufacturer	LED package
12 x 15		Lumileds Luxeon Sharp Nichia LG Innotec	CoB 1202S Mini ZENIGATA / GW6BMG / GW6BGG / GW6BMW / GW6BGW / GW6NGW NTCWT / NTCWS / NVNWS / NJCWS LEMWM12480 / LEMWM12490
13.35 x 13.35		Cree Seoul Semiconductor	CXA13XX / CXB13XX SAW 806 / SAW810 / SAW906 / SAW910
13.5 x 13.5		Citizen	CLU026 / CLU027 / CLU028 / CLU700 / CLU701
15 x 15		Osram	Soleriq P9
15.85 x 15.85		Cree	CXA15XX / CXB15XX
16 x 19		Lumileds Luxeon Nichia LG Innotec	CoB 1202 / CoB 1203 NFCWL / NVEWL / NVCWL LEMWM19480 / LEMWM19490 / LEMWM19680 / LEMWM19690
17.85 x 17.85		Cree	CXA18XX / CXB18XX
18 x 18		Osram	Soleriq S13
19 x 19		Citizen Seoul Semiconductor	CLU036 / CLU038 / CLU710 / CLU711 / CLU720 / CLU721 SAW815 / SAW915
20 x 24		Lumileds Luxeon Sharp LG Innotec	CoB1204 / CoB1205 / CoB1208 Mini ZENIGATA / GW6DMB / GW6DGB / GW6DMC / GW6DGC / GW6DMD / GW6DGD / GW6DME / GW6DGE / GW6TGB / Tiger ZENIGATA / GW6TGC LEMWM24780 / LEMWM24790 / LEMWM24980 / LEMWM24990 / LEMWM24B80 / LEMWM24B90

dimension [mm]	blanks	manufacturer	LED package
23.85 x 23.85		Cree	CXA25XX / CXB25XX
24 x 24		Osram	Solericq S19
27.35 x 27.35		Cree	CXA30XX / CXB30XX
28 x 28		Lumileds Luxeon Citizen Seoul Semiconductor LG Innotec	CoB 1211 CLU046 / CLU048 / CLU731 SAW822 / SAW922 LEMWM28D80 / LEMWM28D90 / LEMWM28E80 / LEMWM28E90
34.85 x 34.85		Cree	CXA35XX / CXB35XX / CXA2Studio
38 x 38		Citizen Seoul Semiconductor Nichia	CLU056 / CLU058 / CLU550 SAW833 / SAW933 NFEWH

Silicone rubber insulating material for semiconductors

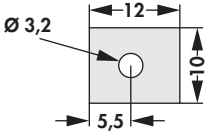
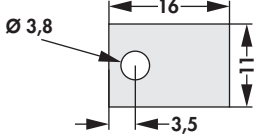
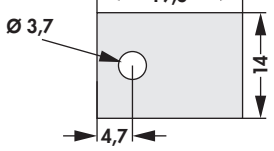
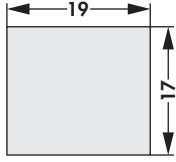
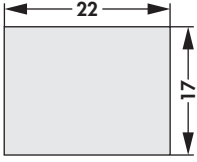
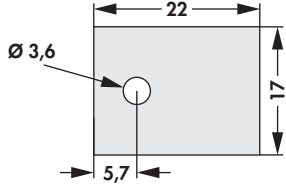
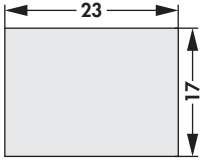
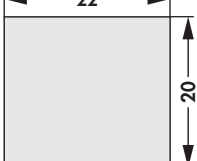
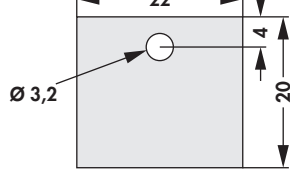
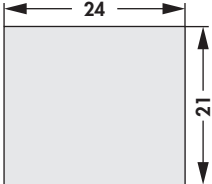
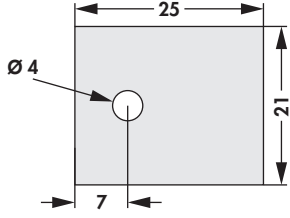
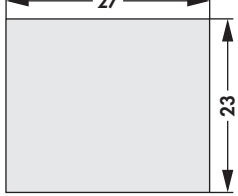
- Cuts from other film materials on request
- Cuts, cut-outs and contours according to customer-specific drawing specifications

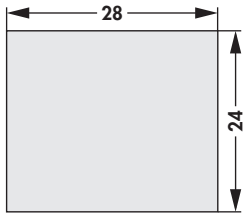
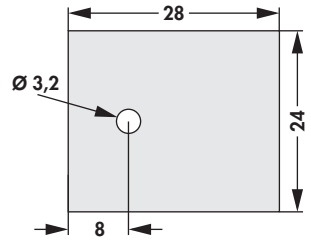
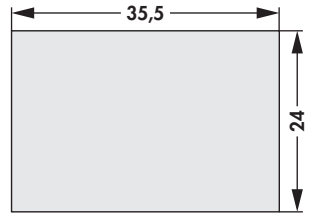
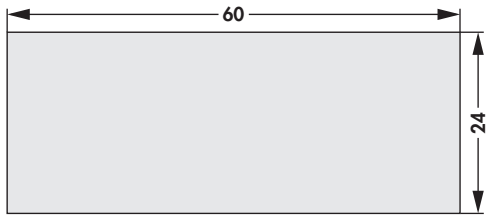
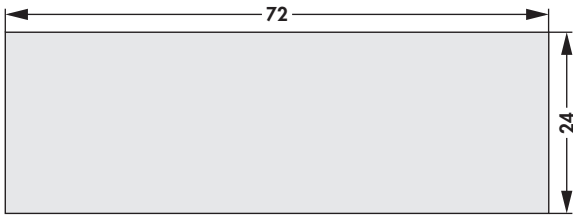
		
<p style="text-align: center;">art. no.</p> <p style="text-align: center;">... 10 x 12 L</p>	<p style="text-align: center;">art. no.</p> <p style="text-align: center;">... 11 x 16 L</p>	<p style="text-align: center;">art. no.</p> <p style="text-align: center;">... 14 x 19,3 L</p>
		
<p style="text-align: center;">art. no.</p> <p style="text-align: center;">... 17 x 19</p>	<p style="text-align: center;">art. no.</p> <p style="text-align: center;">... 17 x 22</p>	<p style="text-align: center;">art. no.</p> <p style="text-align: center;">... 17 x 22 L</p>
		
<p style="text-align: center;">art. no.</p> <p style="text-align: center;">... 17 x 23</p>	<p style="text-align: center;">art. no.</p> <p style="text-align: center;">... 20 x 22</p>	<p style="text-align: center;">art. no.</p> <p style="text-align: center;">... 20 x 22 L</p>
		
<p style="text-align: center;">art. no.</p> <p style="text-align: center;">... 21 x 24</p>	<p style="text-align: center;">art. no.</p> <p style="text-align: center;">... 21 x 25 L</p>	<p style="text-align: center;">art. no.</p> <p style="text-align: center;">... 23 x 27</p>
<p>please indicate:</p> <p style="margin-left: 40px;">... foil type</p> <p style="margin-left: 80px;">WS = foil WS</p> <p style="margin-left: 80px;">WG = foil WG</p> <p style="margin-left: 80px;">WK = foil WK</p> <p style="margin-left: 80px;">WB = foil WB</p>		

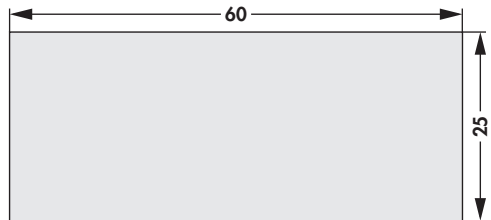
		
art. no.	art. no.	art. no.
... 24 x 28	... 24 x 28 L	... 24 x 35,5
		
art. no.	art. no.	
... 24 x 60	... 24 x 72	
		
art. no.	art. no.	
... 25 x 35	... 25 x 60	
<p>please indicate:</p> <p>... foil type</p> <p>WS = foil WS</p> <p>WG = foil WG</p> <p>WK = foil WK</p> <p>WB = foil WB</p>		

– other cuttings on request

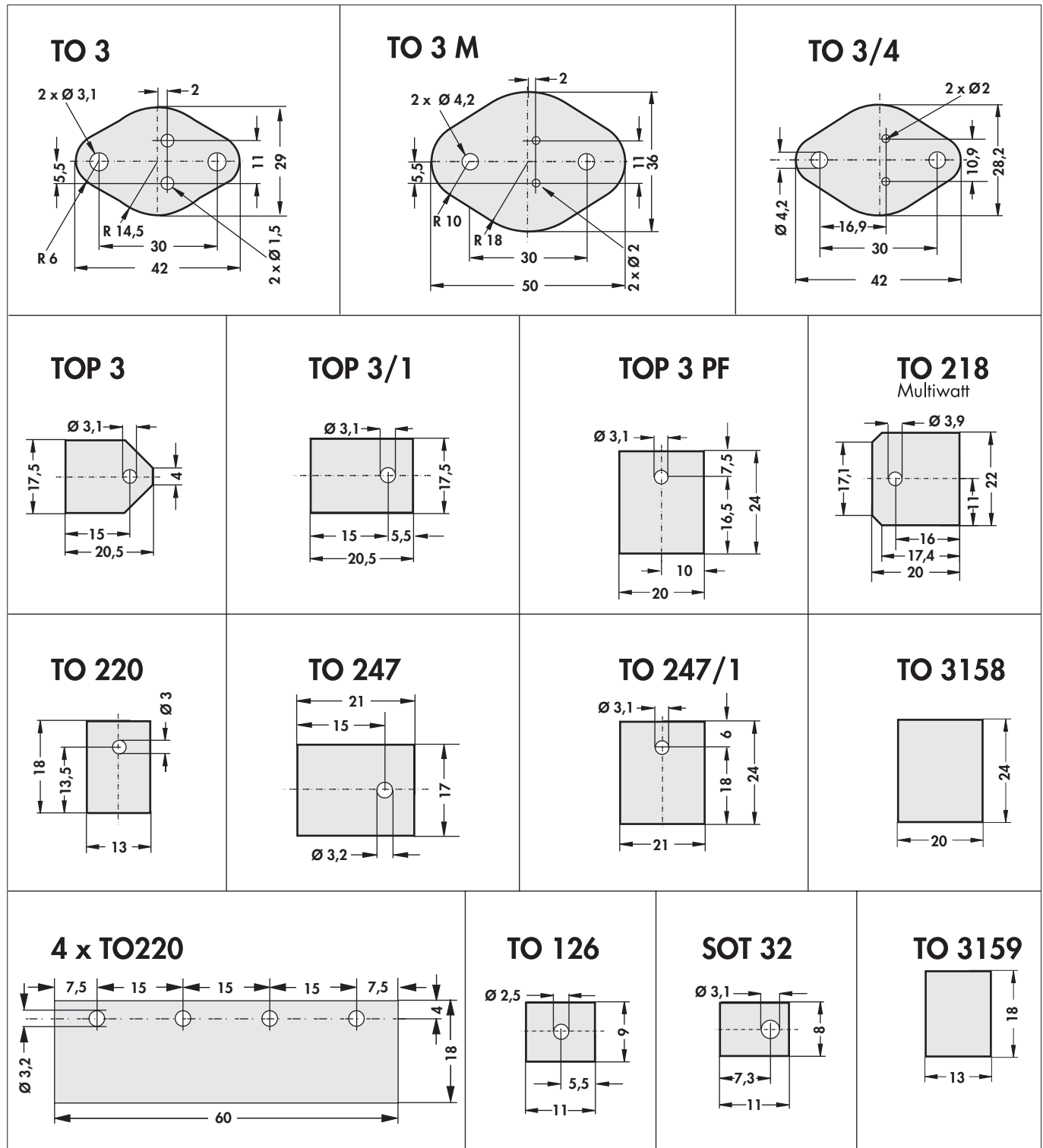

foil type	foil WS	foil WG	foil WK	foil WB
material	silicone foil, standard	silicone foil, GF reinforced	silicone foil, GF reinforced, one side self-adhesive	silicone foil, GF reinforced
washer				
TO-3	WS 3	WG 3	WK 3	WB 3
TO-3 M	WS 3 M			
TO-3/4	WS 3/4		WK 3/4	
TO-3 PF	WS 3 P	WG 3 P	WK 3 P	WB 3 P
3158	WS 3158		WK 3158	WB 3158
TOP 3	WS TOP 3			
TOP 3/1	WS TOP 3/1		WK TOP 3/1	
TO 218 (Multiwatt)		WG 218		
TO 247	WS 247		WK 247	
TO 220	WS 220	WG 220	WK 220	WB 220
4 X TO 220	WS 4 220			
3159	WS 3159		WK 3159	WB 3159
TO 126			WK 126	
SOT 32			WK 32	
TO 247/1	WS 247/1			
insulating tube				
TO-220 Ø 11 mm, length 25 mm	WSC-220			
TO-3 PF Ø 13.5 mm, length 25 mm	WSC-3 P			
TO-247 Ø 14.5 mm, length 30 mm	WSC-247			
insulating tube as meterpiece				
TO-220 Ø 11 mm	WSM-220			
TO-3 PF Ø 13.5 mm	WSM-3 P			
tape material (width)				
24 mm			WKT 24	
30 mm	WST 30		WKT 30	WBT 30
36 mm	WST 36	WGT 36	WKT 36	WBT 36
85 mm	WST 85		WKT 85	
300 mm		WGT 300	WKT 300	WBT 300
	Foil WS	Foil WG	Foil WK	Foil WB
colour		green		brown
material	silicone foil, standard	silicone foil, GF reinforced	silicone foil, GF reinforced, one side self-adhesive	silicone foil, GF reinforced
material thickness	0.3 mm +0.1/ -0	0.2 mm +0.02/ -0.04		0.15 mm +0.02/ -0.04
thermal resistance	0.4 K/W	0.42 K/W	0.45 K/W	0.34 K/W
hardness	75 IRHD	87 IRHD		92 IRHD
thermal conductivity	1,2 W/m·K	0,9 W/m·K		1,44 W/m·K
temperature range	-40°C... +150°C			
insulation resistance	1·10 ¹³ Ω·m			
elongation	100 %	2 %		
dielectric strength	10 kV	6 kV		3 kV
class of inflammability	UL 94 V-0			
storage conditions	-20 °C - +50 °C/ 45 % - 85 % humidity			
shelf life	12 months			

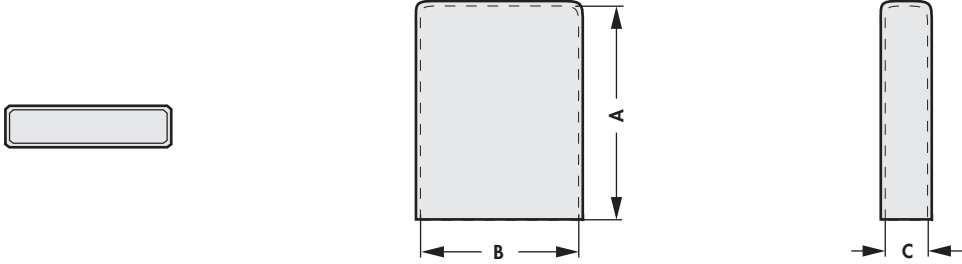

art. no.	type	material thickness	dim. [mm]		
			A	B	C
WSI 220 225	TO 220	0.3 ^{+0.10/} -0.00	22.5	11	5.0
WSI TOP 3 280	TO 3 PL/TO 247		28.0	16	
WSI 220 210	TO 220	0.9 ^{+0.15/} -0.10	21.0	11	
WSI TOP 3 235	TOP 3		23.5	18	
WSI TO 3 PL	TO 3 PL/TO 247		34.0	22	
		Foil WSI 0.3 mm	Foil WSI 0.9 mm		
colour		green			
material thickness		0.3 mm ^{+0.1/} -0	0.9 mm ^{+0.15/} -0.1		
thermal resistance		0.4 K/W	0.96 K/W		
hardness		75 Shore A			
thermal conductivity		1,22 W/m·K			
temperature range		-60°C... +180°C			
insulation resistance		2.9·10 ¹⁵ Ω·cm			
elongation		100 %			
dielectric strength		10 kV	15 kV		
class of inflammability		UL 94 V-0			

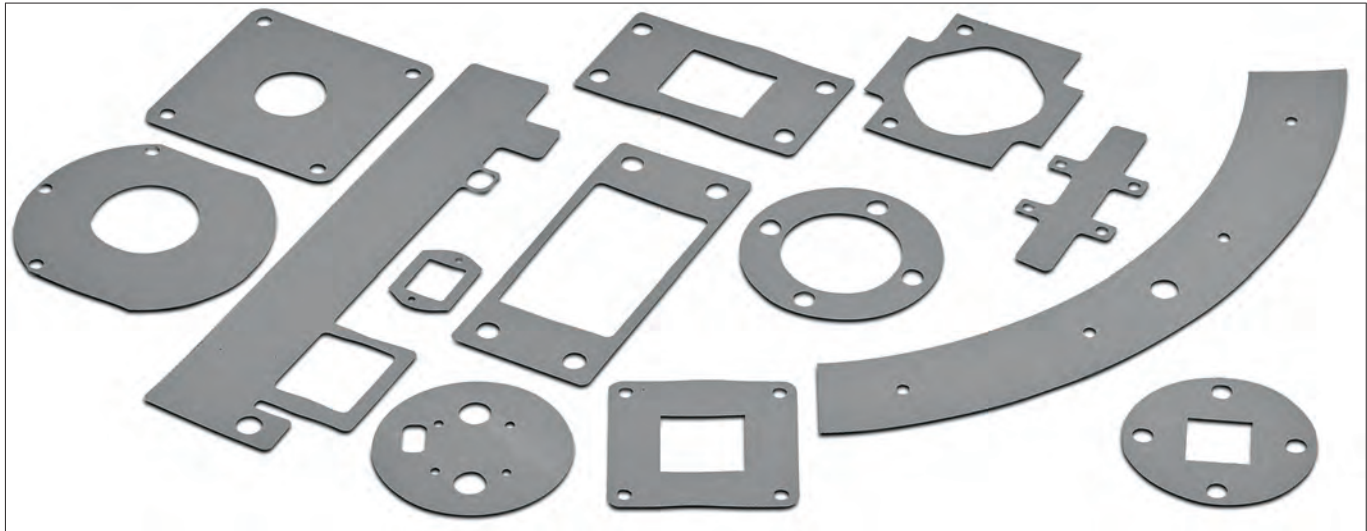

- silicone foil with glass fibre reinforcement
- free from toxic substances
- very good thermal and mechanical properties
- one-sided or double-sided adhesive layer upon request
- cuts and contours according to customer specific drawing specifications

art. no.	material thickness [mm]	art. no.	material thickness [mm]
WFS 09 18	0.178	WFS 09 23	0.229
	WFS 09 18		WFS 09 23
version	silicone foil with glass fibre reinforcement		
colour	grey		
hardness	85 Shore A		
thermal conductivity	0,9 W/m·K		
temperature range	-60°C... +180°C		
elongation	54 %		
volume resistance	10 ¹¹ Ω·m		
dielectric constant	5.5 [1 kHz]		
tear strength	2,900 psi		
tensile strength	5 kN/m		
dielectric strength	3.5 kV		4.5 kV
class of inflammability	UL 94 V-0		
type of delivery	rolled goods, roll width 300mm/ cuttings on customer's requirement		
storage conditions	-20 °C - +50 °C/ 50 % humidity		
shelf life	12 months		

Thermal resistances vs. contact pressure / surface TO 220					
pressure [psi]	10	25	50	100	200
thermal resistance WFS 09 18 [K/W]	6.62	5.93	5.14	4.38	3.61
thermal resistance WFS 09 23 [K/W]	8.51	7.62	6.61	5.63	4.64
thermal impedance WFS 09 18 [K-cm ² /W]	11.37	8.87	7.06	5.12	3.37
thermal impedance WFS 09 23 [K-cm ² /W]	14.62	11.43	9.06	6.56	4.31

Thermally conductive foil made of siliconelastomer

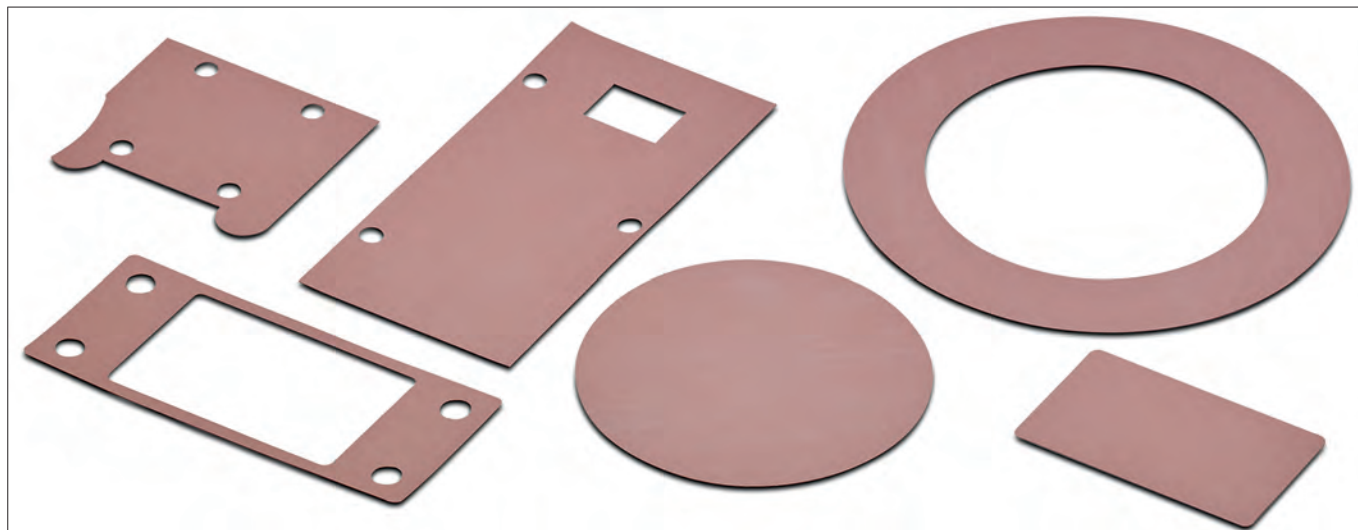

- very good suitable for low tightening torques or spring applications
- good electrical insulating properties
- optimal contacting between device and heatsink
- one-sided adhesive layer upon request
- cuts and contours according to customer specific drawing specifications

art. no.	material thickness [mm]
WFS 16	0.229
	WFS 16
version	silicone foil with glass fibre reinforcement
colour	pink
hardness	92 Shore A
thermal conductivity	1,6 W/m·K
temperature range	-60°C... +180°C
elongation	20 %
volume resistance	10 ¹⁰ Ω·m
dielectric constant	6 [1 kHz]
tear strength	1,300 psi
dielectric strength	5.5 kV
class of inflammability	UL 94 V-0
type of delivery	rolled goods, roll width 300mm/ cuttings on customer's requirement
storage conditions	-20 °C - +50 °C/ 50 % humidity
shelf life	12 months

Thermal resistances vs. contact pressure / surface TO 220					
pressure [psi]	10	25	50	100	200
thermal resistance WFS 16 [K/W]	3.96	3.41	2.90	2.53	2.32
thermal impedance WFS 16 [K·cm ² /W]	5.93	4.68	3.81	2.93	2.56

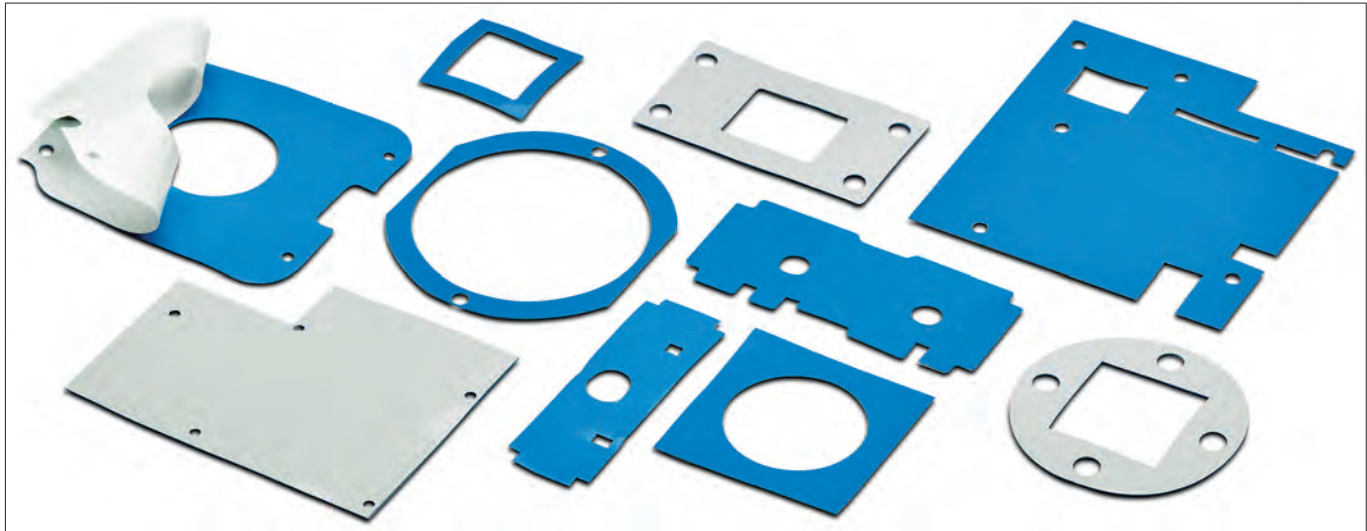

- silicone material with glass fibre reinforcement
- optimal contacting between device and heatsink
- simplified mounting by means of double-sided adhesive layer
- automatic assembling possible
- cuts and contours according to customer specific drawing specifications

art. no.	material thickness [mm]
WFS 18	0.203
	WFS 18
version	silicone foil with glass fibre reinforcement
colour	blue
hardness	75 Shore A
thermal conductivity	1,8 W/m·K
temperature range	-60°C... +180°C
elongation	22 %
volume resistance	10 ¹¹ Ω·m
dielectric constant	6.1 [1 kHz]
tear strength	238 psi
tensile strength	0,34 kN/m
dielectric strength	3 kV
class of inflammability	UL 94 V-0
type of delivery	rolled goods, roll width 250mm/ cuttings on customer's requirement
storage conditions	-20 °C - +50 °C/ 50 % humidity
shelf life	12 months

Thermal resistances vs. contact pressure / surface TO 220					
pressure [psi]	10	25	50	100	200
thermal resistance WFS 18 [K/W]	1.54	1.52	1.51	1.49	1.46
thermal impedance WFS 18 [K·cm ² /W]	2.31	1.75	1.43	1.31	1.25

Thermally conductive foil made of siliconelastomer

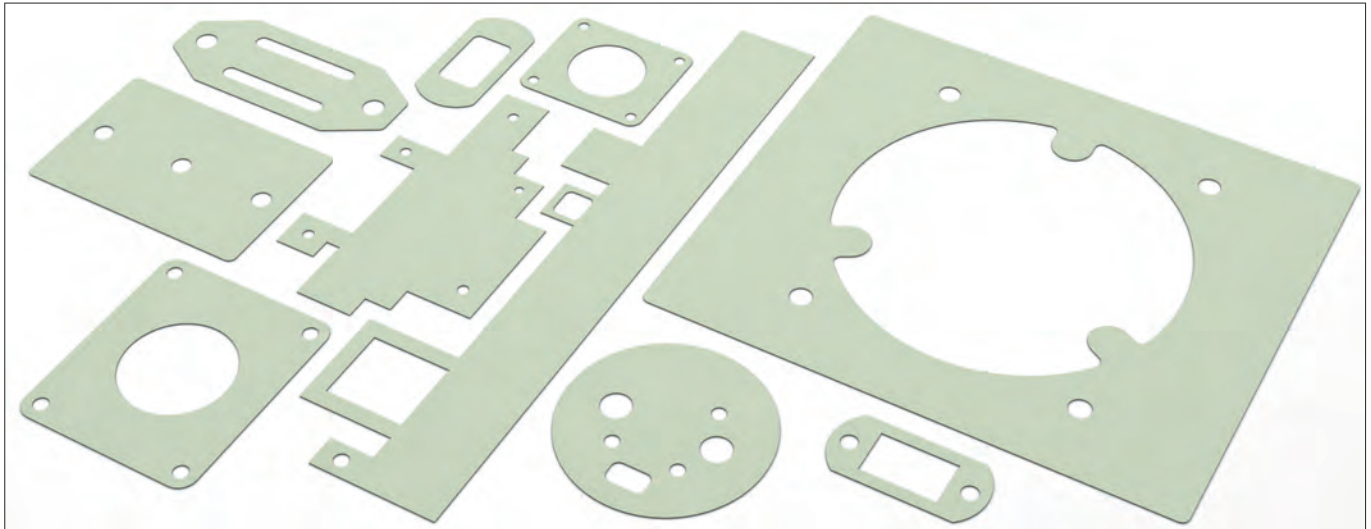

- silicone foil with a high operating temperature range
- high mechanical stability
- easy handling and application
- cuts, punch-outs and contours according to customer-specific drawing specifications

art. no.	material thickness [mm]	art. no.	material thickness [mm]	
WFK 18	0.225	WFK 18 GK	0.250	
WFK 18 G		WFK 18 K		
	WFK 18	WFK 18 G	WFK 18 GK	WFK 18 K
version	silicone foil without glass fibre reinforcement, one-sided protection foil	silicone foil with glass fibre reinforcement, one-sided protection foil	silicone foil with glass fibre reinforcement and one-sided adhesive layer, one-sided protection foil	silicone foil without glass fibre reinforcement and one-sided adhesive layer, one-sided protection foil
colour	lime-green			
density	2.29 g/cm ³			
hardness	65 - 75 Shore A			
thermal conductivity	1,8 W/m·K			
thermal resistance	0.32 K/W	0.5 K/W	0.55 K/W	0.39 K/W
temperature range	-60°C ... +250°C			
elongation	75 %			
volume resistance	2.5·10 ¹¹ Ω·m			
dielectric constant	2.9 [1 kHz]			
tensile strength	2 N/mm ²	7,5 N/mm ²		2 N/mm ²
dielectric strength	8 kV			
class of inflammability	UL 94 V-0			
type of delivery	plates, usable area 300x250mm/ other dimensions upon request			
storage conditions	+18 °C - +28 °C/ 30 % - 70 % humidity			
shelf life	almost unlimited		12 months	

Thermal resistances vs. contact pressure				
pressure [psi]	7.25	29	58	87
thermal resistance WFK 18 [K/W]	0.50	0.42	0.37	0.33
thermal impedance WFK 18 [K·cm ² /W]	1.75	1.38	1.25	1.18

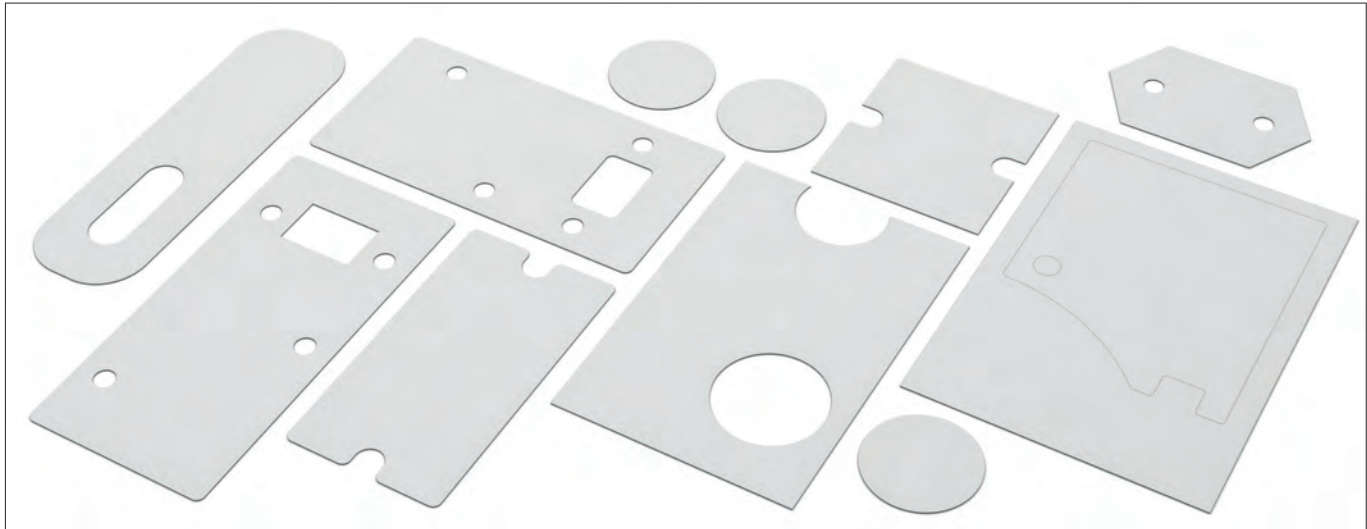

- silicone foil with very good thermal properties
- good electrical insulation resistance
- easy handling and application
- cuts and contours according to customer specifications

art. no.	material thickness [mm]		art. no.	material thickness [mm]
WFK 25	0.225		WFK 25 GK	0.250
WFK 25 G			WFK 25 K	
	WFK 25	WFK 25 G	WFK 25 GK	WFK 25 K
version	silicone foil without glass fibre reinforcement, one-sided protection foil	silicone foil with glass fibre reinforcement, one-sided protection foil	silicone foil with glass fibre reinforcement and one-sided adhesive layer, one-sided protection foil	silicone foil without glass fibre reinforcement and one-sided adhesive layer, one-sided protection foil
colour	white			
density	2.33 g/cm ³			
hardness	70 - 80 Shore A			
thermal conductivity	2,5 W/m·K			
thermal resistance	0,22 K/W	0,25 K/W	0,3 K/W	0,265 K/W
temperature range	-60°C ... +250°C			
elongation	31 %			
volume resistance	2.5·10 ¹¹ Ω·m			
dielectric constant	3 [1 kHz]			
tensile strength	1,5 N/mm ²	7,5 N/mm ²		1,5 N/mm ²
dielectric strength	1.5 kV			
class of inflammability	UL 94 V-0			
type of delivery	plates, usable area 300x250mm/ other dimensions upon request		plates, usable area 300x235mm/ other dimensions upon request	
storage conditions	+18 °C - +28 °C/ 30 % - 70 % humidity			
shelf life	almost unlimited		12 months	

Thermal resistances vs. contact pressure				
pressure [psi]	7.25	29	58	87
thermal resistance WFK 25 [K/W]	0.38	0.33	0.30	0.27
thermal impedance WFK 25 [K·cm ² /W]	1.13	1.00	0.92	0.83

Thermally conductive foil made of siliconelastomer



- silicone film with very good thermal conductivity
- good mechanical properties
- adhesive coating (... **K**) for easy installation handling
- cuts and contours according to customer-specific drawing specifications

art. no.	material thickness [mm]		art. no.	material thickness [mm]		
WFP 30 020	0.20 ±0.05		WFP 30 020 K	0.20 ±0.05		
WFP 30 030	0.30 ±0.10		WFP 30 030 K	0.30 ±0.10		
WFP 30 045	0.45 ±0.05		WFP 30 045 K	0.45 ±0.05		
	WFP 30 020	WFP 30 030	WFP 30 045	WFP 30 020 K	WFP 30 030 K	WFP 30 045 K
version	silicone foil with glass fibre reinforcement			silicone foil with glass fibre reinforcement and one-sided adhesive layer		
colour	white					
hardness	80 IRHD	87 IRHD		80 IRHD	87 IRHD	
thermal conductivity	3 W/m·K					
temperature range	-40°C... +150°C					
elongation	≤3 %					
volume resistance	2·10 ¹⁵ Ω·m					
dielectric constant	2.4 [50 Hz] / 2.4 [1 kHz] / 2.4 [1 MHz]	3.4 [50 Hz] / 3.3 [1 kHz] / 3.3 [1 MHz]	4 [50 Hz] / 3.9 [1 kHz] / 3.9 [1 MHz]	2.4 [50 Hz] / 2.4 [1 kHz] / 2.4 [1 MHz]	3.4 [50 Hz] / 3.3 [1 kHz] / 3.3 [1 MHz]	4 [50 Hz] / 3.9 [1 kHz] / 3.9 [1 MHz]
dielectric loss factor	0.032 [50 Hz] / 0.007 [1 kHz] / 0.003 [1 MHz]	0.026 [50 Hz] / 0.007 [1 kHz] / 0.004 [1 MHz]	0.021 [50 Hz] / 0.006 [1 kHz] / 0.003 [1 MHz]	0.032 [50 Hz] / 0.007 [1 kHz] / 0.003 [1 MHz]	0.026 [50 Hz] / 0.007 [1 kHz] / 0.004 [1 MHz]	0.021 [50 Hz] / 0.006 [1 kHz] / 0.003 [1 MHz]
tear strength	6,888 psi	3,364 psi	3,161 psi	6,888 psi	3,364 psi	3,161 psi
dielectric strength	10 kV (AC)	11 kV (AC)	12 kV (AC)	10 kV (AC)	11 kV/mm	12 kV (AC)
class of inflammability	UL 94 V-0					
type of delivery	rolled goods, roll width 150mm/ cuttings on customer's requirement					
storage conditions	-20 °C - +50 °C/ 45 % - 85 % humidity					
shelf life	12 months			6 months		

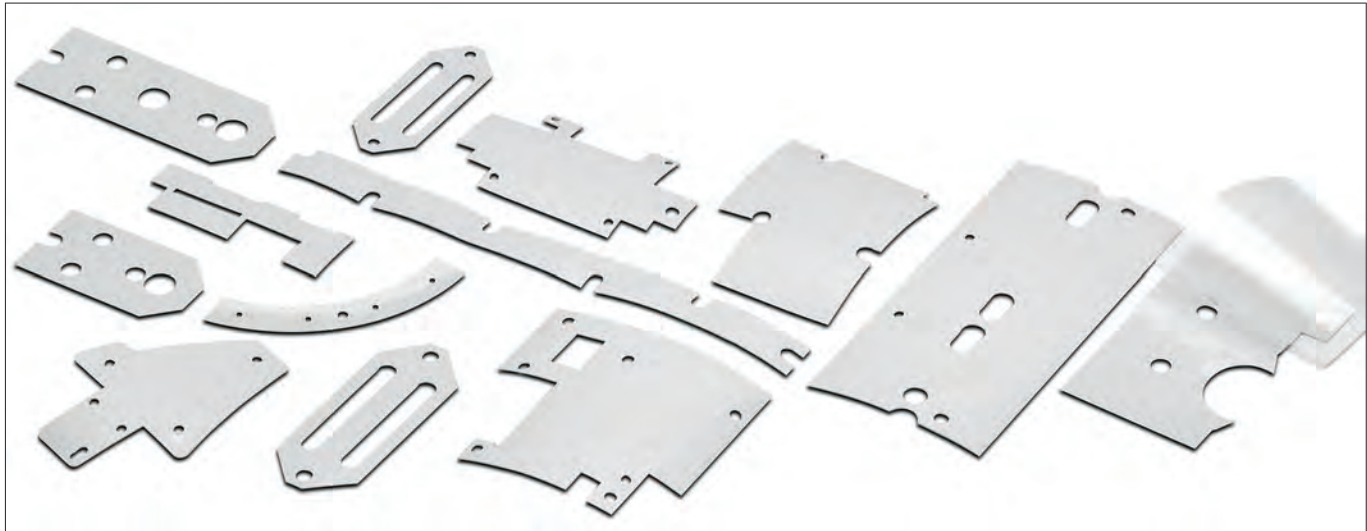

- silicone-foil with very good thermal properties
- excellent insulating properties
- simple and stable handling by means of glass fibre carrier material
- one-sided adhesive layer upon request
- cuts and contours according to customer specific drawing specifications

art. no.	material thickness [mm]
WFSA 30 50	0.508
	WFSA 30 50
version	silicone foil with glass fibre reinforcement
colour	white
hardness	90 Shore A
thermal conductivity	3 W/m·K
temperature range	-60°C ... +200°C
volume resistance	10 ¹¹ Ω·m
dielectric constant	7 [1 kHz]
heat capacity	1 J/g·K
dielectric strength	4 kV
class of inflammability	UL 94 V-0
type of delivery	rolled goods, roll width 250mm/ cuttings on customer's requirement
storage conditions	+20 °C - +50 °C/ 50 % humidity
shelf life	6 months



- silicone foil with very good thermal conduction properties
- high dimensional stability due to glass fibre layer
- good electrical properties
- excellent processing properties
- contour and drawing parts according to customer specifications

art. no.	material thickness [mm]
WFS 34 020	0.20
WFS 34 030	0.30
WFS 34 045	0.45

WFS 34	
version	silicone foil with glass fibre reinforcement
colour	dark gray
density	2.8 g/cm ³
hardness	90 Shore A
thermal conductivity	3,4 W/m·K
temperature range	-40°C ... +180°C
volume resistance	3·10 ¹³ Ω·cm
dielectric strength	37 kV/mm
class of inflammability	UL 94 V-0
type of delivery	rolled goods, roll width 300mm/ other dimensions upon request
storage conditions	+1 °C - +30 °C/ cool and dark
shelf life	6 months

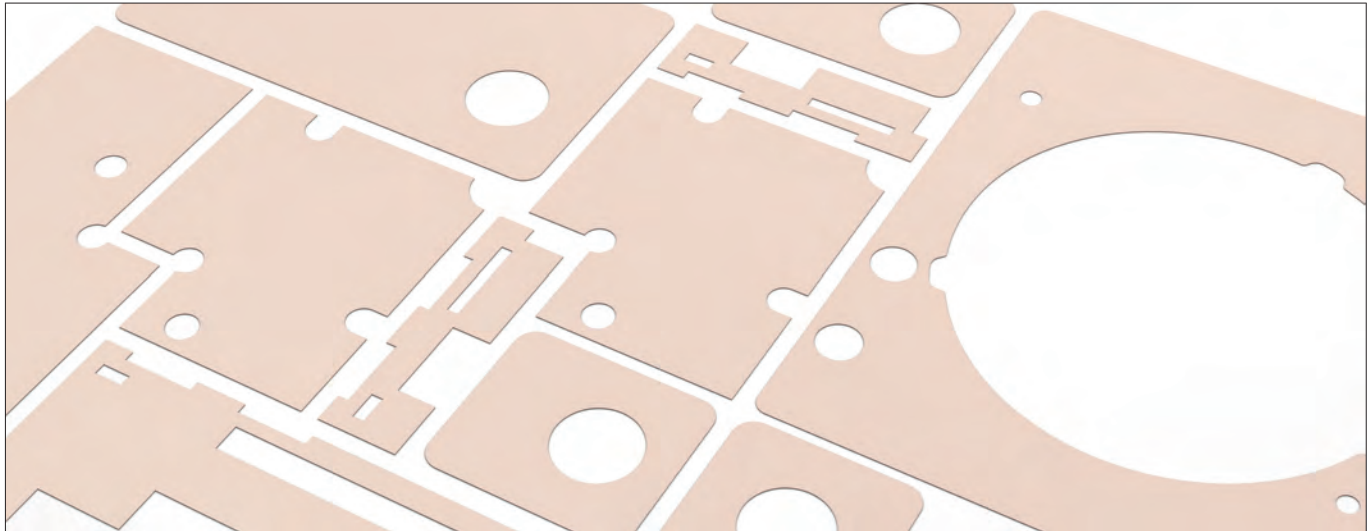

- silicone foil with very good thermal conductivity
- high insulation and dielectric strength
- very large operating temperature range
- one-sided adhesive coating as an mounting aid
- customer-specific cuts and punch-outs according to drawing

art. no.	material thickness [mm]			
WFK 35 012	0.125			
WFK 35 022	0.225			
WFK 35 G	0.250			
WFK 35 GK	0.250			
WFK 35 K	0.250			
	WFK 35	WFK 35 G	WFK 35 GK	WFK 35 K
version	silicone foil without glass fibre reinforcement, one-sided protection foil	silicone foil with glass fibre reinforcement, one-sided protection foil	silicone foil with glass fibre reinforcement and one-sided adhesive layer, one-sided protection foil	silicone foil without glass fibre reinforcement and one-sided adhesive layer, one-sided protection foil
colour	pink			
density	1.97 g/cm ³			
hardness	70 - 80 Shore A			
thermal conductivity	3,5 W/m·K			
thermal resistance	0.16 K/W	0.22 K/W	0.27 K/W	0.26 K/W
temperature range	-60°C ... +250°C			
elongation	25 %			
volume resistance	1.3·10 ¹⁴ Ω·m			
dielectric constant	2.3 [1 kHz]			
tensile strength	1,3 N/mm ²	10 N/mm ²		1,3 N/mm ²
dielectric strength	1.5 kV			
class of inflammability	UL 94 V-0			
type of delivery	plates, usable area 300x250mm/ other dimensions upon request		plates, usable area 300x235mm/ other dimensions upon request	
storage conditions	+18 °C - +28 °C/ 30 % - 70 % humidity			
shelf life	almost unlimited		12 months	

Thermal resistances vs. contact pressure				
pressure [psi]	7.25	29	58	87
thermal resistance WFK 35 [K/W]	0.25	0.21	0.17	0.15
thermal impedance WFK 35 [K·cm²/W]	0.94	0.81	0.75	0.56

Thermally conductive foil made of siliconelastomer



- silicone foil with ceramic filling and high thermal conductivity
- optimal connection of electronic components
- high mechanical stability and easy handling
- extreme aging- and chemical resistance
- special cuts or geometries according to customer specifications

art. no.	material thickness [mm]	art. no.	material thickness [mm]	
WFC 50 02	0.20	WFC 50 04	0.45	
WFC 50 03	0.30	WFC 50 08	0.80	
	WFC 50 02	WFC 50 03	WFC 50 04	WFC 50 08
version	silicone foil with ceramic filling and glass fibre reinforced design, revêtement unilatéral			
colour	white			
thermal conductivity	5 W/m·K			
temperature range	-50°C ... +200°C			
volume resistance	1.7·10 ¹³ Ω·m	7.9·10 ¹³ Ω·m	9.2·10 ¹³ Ω·m	8.9·10 ¹³ Ω·m
dielectric constant	3.3 [1 MHz]			
dielectric strength	3 kV	6 kV	9 kV	> 10 kV
class of inflammability	UL 94 V-0			
type of delivery	plates, usable area 440x510mm/ other dimensions upon request			
storage conditions	< +35 °C/ < 85 % humidity			
shelf life	12 months			

Thermal resistances vs. contact pressure		
pressure [psi]	29	145
thermische impedance WFC 50 02 [K·cm ² /W]	1.87	0.71
thermische impedance WFC 50 03 [K·cm ² /W]	2.06	0.96
thermische impedance WFC 50 04 [K·cm ² /W]	2.26	1.10
thermische impedance WFC 50 08 [K·cm ² /W]	3.35	1.74

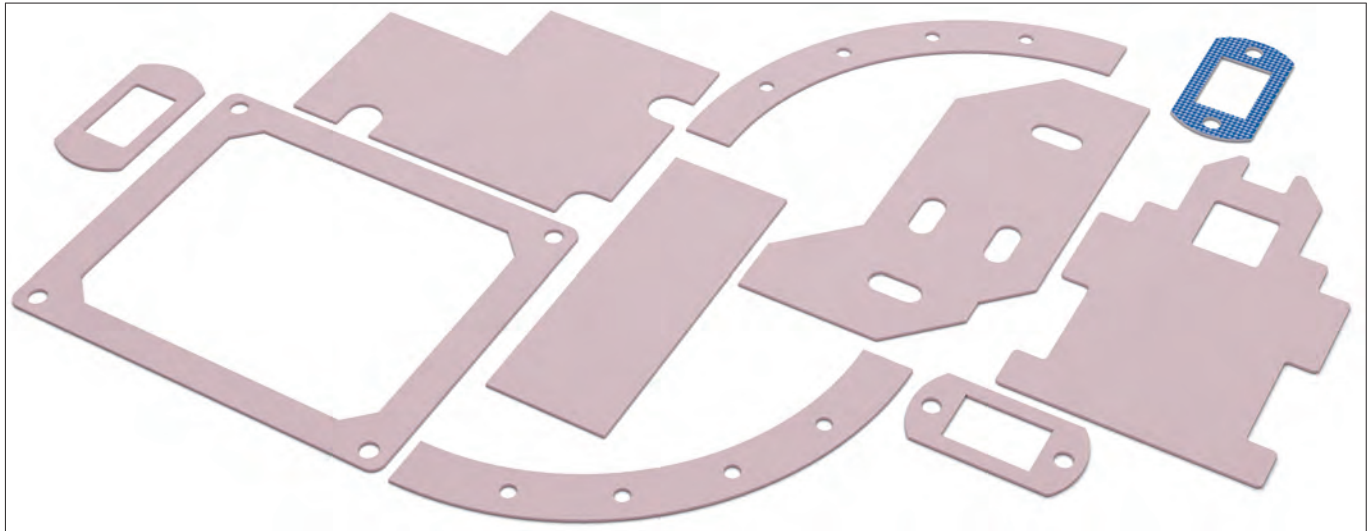

- silicone foil with excellent thermal conductivity
- very good electrical properties
- adhesive coating for easy assembly handling
- particularly suitable for high-performance applications
- cuts and contours according to customer's drawing specifications

art. no.	material thickness [mm]	
WFK 65	0.250	
WFK 65 K	0.275	
	WFK 65	WFK 65 K
version	silicone foil without glass fibre reinforcement, one-sided protection foil	silicone foil with adhesive layer, one-sided protection foil
colour	red	
density	1.23 g/cm ³	
hardness	60 - 70 Shore A	
thermal conductivity	6,5 W/m·K	
thermal resistance	0,09 K/W	
temperature range	-40°C... +200°C	
elongation	2 %	
volume resistance	2·10 ¹⁴ Ω·m	
dielectric constant	2.4 [1 kHz]	
tensile strength	13 N/mm ²	
dielectric strength	1 kV	
class of inflammability	UL 94 V-0	
type of delivery	plates, usable area 300x250mm/ other dimensions upon request	plates, usable area 300x235mm/ other dimensions upon request
storage conditions	+18 °C - +28 °C/ 30 % - 70 % humidity	
shelf life	almost unlimited	12 months

Thermal resistances vs. contact pressure				
pressure [psi]	7.25	29	58	87
thermal resistance WFK 65 [K/W]	0.18	0.12	0.10	0.08
thermal impedance WFK 65 [K-cm ² /W]	0.68	0.50	0.39	0.31

Thermally conductive foil made of siliconelastomer

- silicone foil with excellent thermal conductivity
- very good insulation properties
- high material strength due to glass fibre reinforcement
- simple handling and application
- customised cuts and geometries according to drawing

art. no.	material thickness [mm]
WFS 80 020	0.20
WFS 80 030	0.30
WFS 80 045	0.45

WFS 80	
version	silicone foil with glass fibre reinforcement
colour	light gray
density	1.6 g/cm ³
hardness	85 Shore A
thermal conductivity	8 W/m·K
temperature range	-40°C ... +180°C
volume resistance	2.9·10 ¹⁴ Ω·cm
tear strength	1,885 psi
tensile strength	45 kN/m
dielectric strength	50 kV/mm
class of inflammability	UL 94 V-0
type of delivery	plates, usable area 420x500mm/ other dimensions upon request
storage conditions	+1 °C - +30 °C/ cool and dark
shelf life	6 months

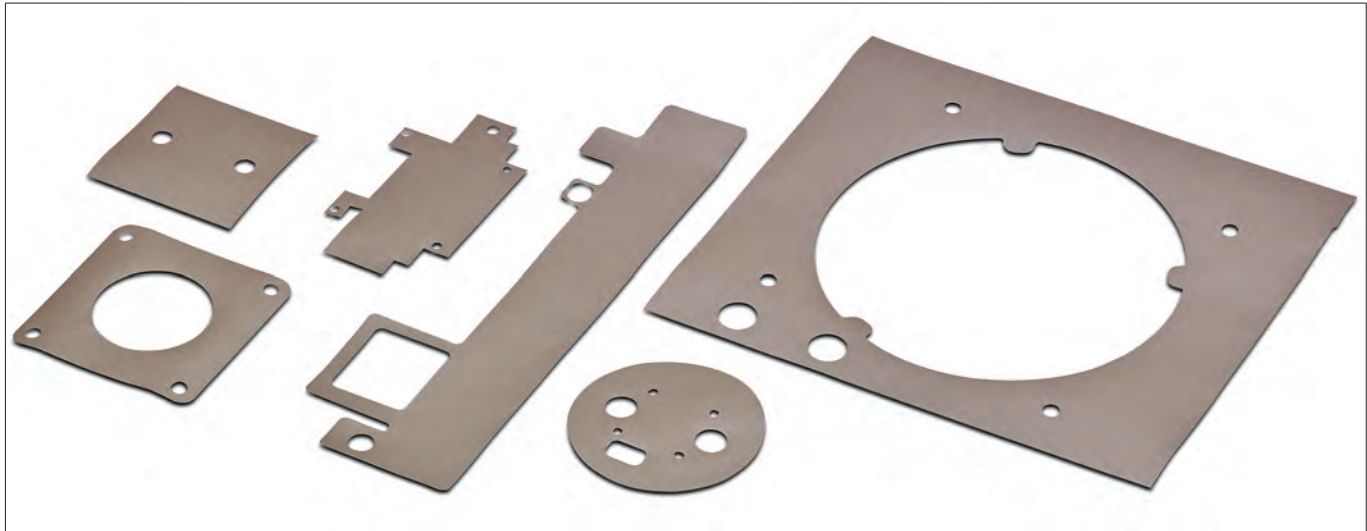

- thermal conductive foil based on polyester
- particularly suitable for silicone-free applications
- very good insulating properties
- one-sided adhesive layer upon request
- cuts and contours according to customer specific drawing specifications

art. no.	material thickness [mm]
WFPK 09	0.152
	WFPK 09
version	kapton carrier foil with ceramic filled polyester resin double-sided fully coated
colour	brown
hardness	90 Shore A
thermal conductivity	0,9 W/m·K
temperature range	-20°C... +150°C
elongation	40 %
volume resistance	10 ¹² Ω·m
dielectric constant	5 [1 kHz]
tear strength	5,000 psi
tensile strength	5 kN/m
dielectric strength	6 kV
class of inflammability	UL 94 V-0
type of delivery	rolled goods, roll width 292mm/ cuttings on customer's requirement
storage conditions	-20 °C - +50 °C/ 50 % humidity
shelf life	12 months

Thermal resistances vs. contact pressure / surface TO 220					
pressure [psi]	10	25	50	100	200
thermal resistance WFPK 09 [K/W]	5.64	5.04	4.34	3.69	3.12
thermal impedance WFPK 09 [K-cm ² /W]	9.68	7.56	5.93	4.37	2.87

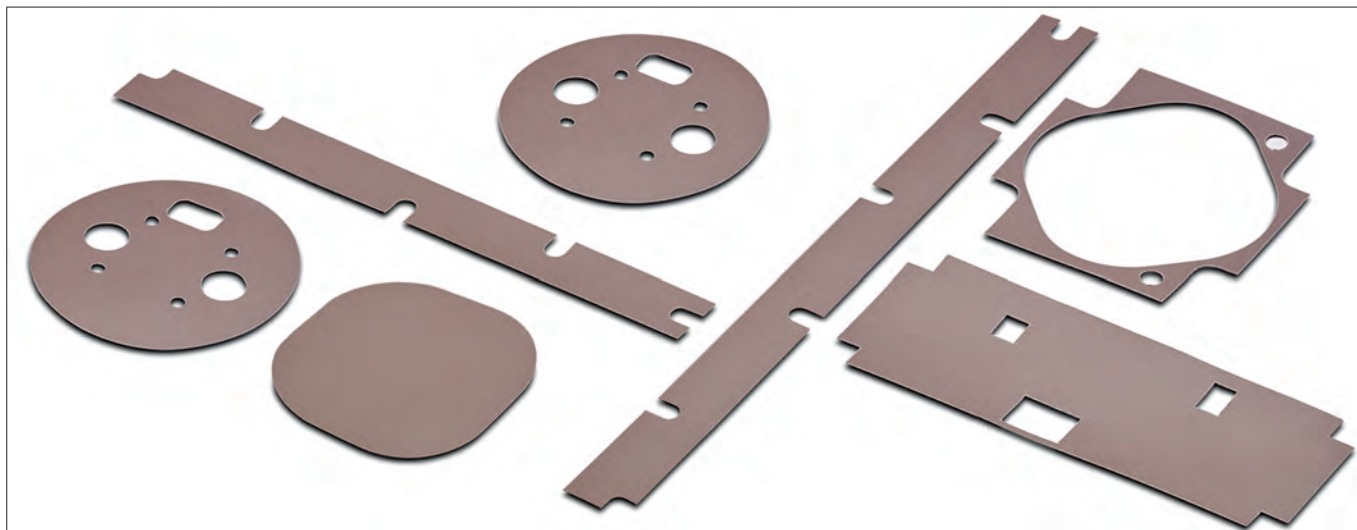

- thermal conductive foil based on polyester
- particularly suitable for silicone-free applications
- very good thermal and mechanical properties
- simplified mounting by means of adhesive layers upon request
- cuts and contours made of sheet or roll material as per your specifications

art. no.	material thickness [mm]
WFP 09	0.229
	WFP 09
version	glass fibre-carrier foil with ceramic filled polyester resin double-sided fully coated
colour	brown
hardness	90 Shore A
thermal conductivity	0,9 W/m·K
temperature range	-20°C... +150°C
elongation	10 %
volume resistance	10 ¹¹ Ω·m
dielectric constant	5.5 [1 kHz]
tear strength	7,000 psi
tensile strength	18 kN/m
dielectric strength	2.5 kV
class of inflammability	UL 94 V-0
type of delivery	rolled goods, roll width 300mm/ cuttings on customer's requirement
storage conditions	-20 °C - +50 °C/ 50 % humidity
shelf life	12 months

Thermal resistances vs. contact pressure / surface TO 220					
pressure [psi]	10	25	50	100	200
thermal resistance WFP 09 [K/W]	5.85	5.61	5.13	4.59	4.12
thermal impedance WFP 09 [K-cm ² /W]	10.12	8.43	7.06	5.37	3.81

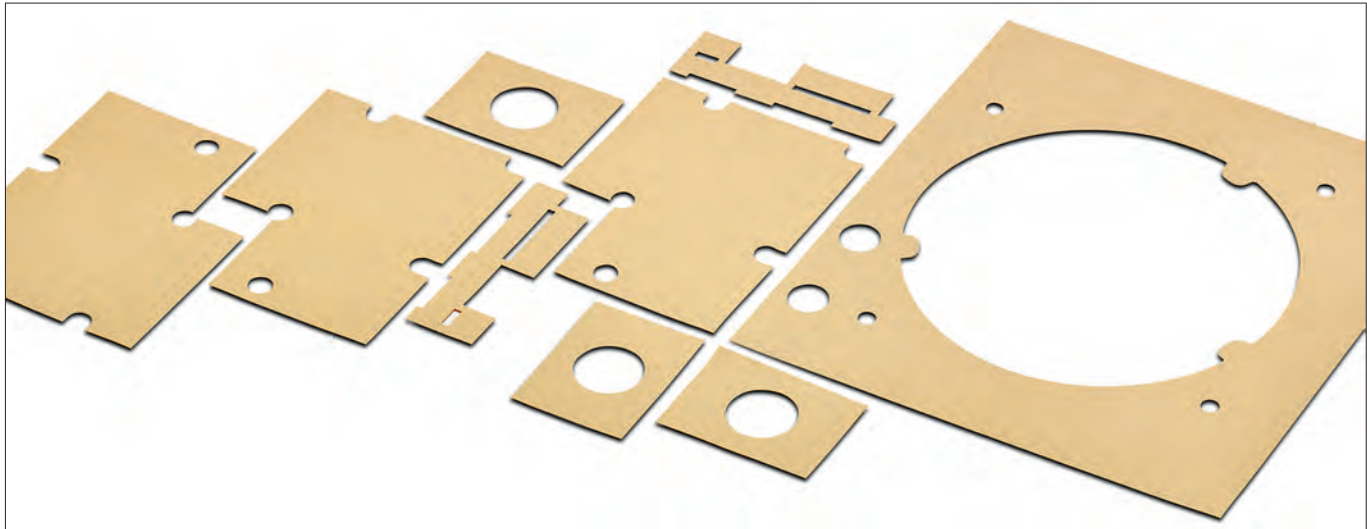

- thermal conductive foil for silicone-free applications
- thermal conductive foil based on polyester
- very good insulating properties
- one-sided adhesive layer upon request
- cuts and contours according to customer specific drawing specifications

art. no.	material thickness [mm]
WFPK 13	0.152
	WFPK 13
version	kapton carrier foil with ceramic filled polyester resin double-sided fully coated
colour	yellow
hardness	90 Shore A
thermal conductivity	1,3 W/m·K
temperature range	-20°C... +150°C
elongation	40 %
volume resistance	10 ¹² Ω·m
dielectric constant	3.7 [1 kHz]
tear strength	5,000 psi
tensile strength	5 kN/m
dielectric strength	6 kV
class of inflammability	UL 94 V-0
type of delivery	rolled goods, roll width 292mm/ cuttings on customer's requirement
storage conditions	-20 °C - +50 °C/ 50 % humidity
shelf life	12 months

Thermal resistances vs. contact pressure / surface TO 220					
pressure [psi]	10	25	50	100	200
thermal resistance WFPK 13 [K/W]	3.76	3.35	2.75	2.30	2.03
thermal impedance WFPK 13 [K-cm ² /W]	6.50	5.00	3.75	2.68	1.88



- polyurethane-based thermal conductive foil
- very good mechanical properties
- excellent insulation properties
- adhesive coating for easy handling
- cut to size and contours according to customised drawing specifications

art. no.	material thickness [mm]
WFKF 18 015	0.150
WFKF 18 017 K	0.175
WFKF 18 032 K	0.325

	WFKF 18 015	WFKF 18 ... K
version	ceramic-filled heat-conducting foil based on polyurethane, one-sided protective film	ceramic-filled heat-conducting foil based on polyurethane including adhesive coating, one-sided protective film
colour	blue	
density	2.26 g/cm ³	
hardness	80 - 90 Shore A	
thermal conductivity	1,8 W/m·K	
thermal resistance	0.2 K/W	
temperature range	-40°C... +125°C	
elongation	130 %	
volume resistance	1.4·10 ¹⁴ W·m	
dielectric constant	3.2 [1 kHz]	
tensile strength	3 N/mm ²	
dielectric strength	4 kV	
class of inflammability	UL 94 V-0	
type of delivery	plates, usable area 500x470mm/ other dimensions upon request	plates, usable area 500x460mm/ other dimensions upon request
storage conditions	+18 °C - +28 °C/ 30 % - 70 % humidity	
shelf life	almost unlimited	12 months

Thermal resistances vs. contact pressure				
pressure [psi]	7.25	29	58	87
thermal resistance WFKF 18 [K/W]	0.19	0.15	0.12	0.11
thermal impedance WFKF 18 [K-cm ² /W]	1.23	0.94	0.74	0.70

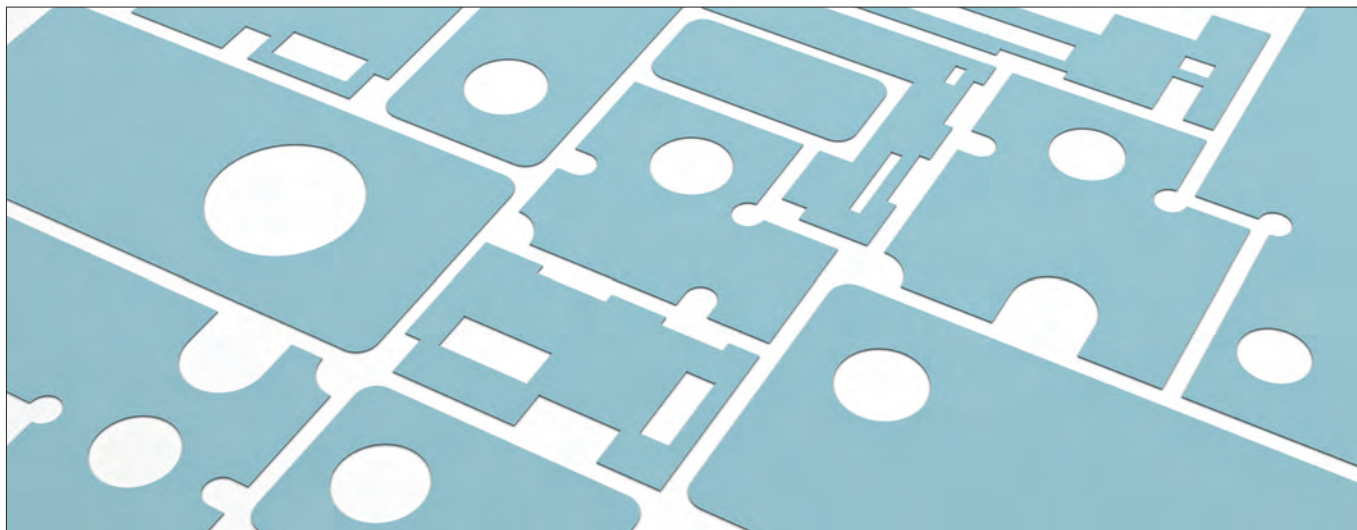

- thermal conductive foil for silicone-free applications
- epoxy-based thermal conductive foil
- excellent insulation properties
- cuts and contours according to customised drawing specifications

art. no.	material thickness [mm]
WFKF 30 02	0.2
	WFKF 30 02
version	silicone-free, ceramic-filled heat conducting foil
colour	light blue
density	1.44 g/cm ³
hardness	70 - 85 Shore A
thermal conductivity	3 W/m·K
thermal resistance	0.165 K/W
temperature range	-40°C... +150°C
elongation	>50 %
volume resistance	4.1·10 ⁹ Ω·m
dielectric constant	2 [1 kHz]
tensile strength	1 N/mm ²
dielectric strength	6 kV
class of inflammability	UL 94 V-0
type of delivery	plates, usable area 500x500mm/ other dimensions upon request
storage conditions	+18 °C - +28 °C/ 30 % - 70 % humidity
shelf life	almost unlimited

Thermal resistances vs. contact pressure				
pressure [psi]	7.25	29	58	87
thermal resistance WFKF 30 02 [K/W]	0.25	0.18	0.16	0.16
thermal impedance WFKF 30 02 [K·cm ² /W]	0.49	0.35	0.32	0.31

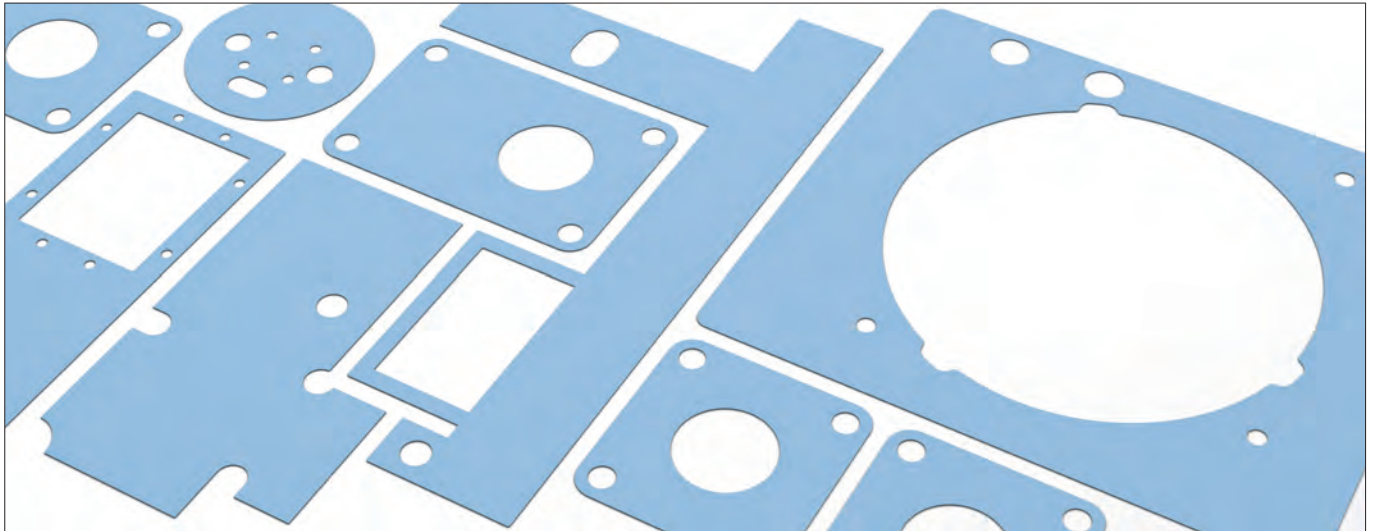

- heat conductive foil based on polyurethane
- very good mechanical properties
- high thermal conductivity for smallest heat transfer resistances
- adhesive coating for easy handling (WFK 60 K)
- cuts and contours according to customer's drawing specifications

art. no.	material thickness [mm]
WFK 60 01	0.100
WFK 60 02	0.200
WFK 60 03	0.300
WFK 60 K	0.225

	WFK 60	WFK 60 K
version	ceramic-filled heat-conducting foil based on polyurethane	ceramic-filled heat-conducting foil based on polyurethane including adhesive coating, one-sided protective film
colour	light blue	
density	1.46 g/cm ³	
hardness	70 - 85 Shore A	
thermal conductivity	6 W/m·K	
thermal resistance	0.082 K/W	
temperature range	-40°C... +125°C	
elongation	150 %	
volume resistance	2·10 ¹¹ Ω·m	
dielectric constant	3.1 [1 kHz]	
tensile strength	2 N/mm ²	
dielectric strength	4 kV	
class of inflammability	UL 94 V-0	
type of delivery	plates, usable area 300x235mm/ other dimensions upon request	plates, usable area 300x230mm/ other dimensions upon request
storage conditions	+18 °C - +28 °C/ 30 % - 70 % humidity	
shelf life	almost unlimited	12 months

Thermal resistances vs. contact pressure				
pressure [psi]	7.25	29	58	87
thermal resistance WFK 60 [K/W]	0.24	0.16	0.12	0.09
thermal impedance WFK 60 [K-cm ² /W]	0.88	0.56	0.38	0.31



- double-sided coated aluminium foil
- good replacement for thermal pastes
- electroconductive with wide temperature range
- low heat-transmission resistance between device and heatsink
- cuts and contours according to customer specific drawing specifications

art. no.	material thickness [mm]
WFQ 25	0.152
	WFQ 25
version	aluminium foil with double-sided coating
colour	black
hardness	93 Shore A
thermal conductivity	2,5 W/m·K
temperature range	-60°C... +180°C
volume resistance	10 ² Ω·m
dielectric strength	electrically conductive
class of inflammability	UL 94 V-0
type of delivery	rolled goods, roll width 300mm/ cuttings on customer's requirement
storage conditions	-20 °C - +50 °C/ 50 % humidity
shelf life	12 months

Thermal resistances vs. contact pressure / surface TO 220					
pressure [psi]	10	25	50	100	200
thermal resistance WFQ 25 [K/W]	2.44	1.73	1.23	1.05	0.92
thermal impedance WFQ 25 [K·cm ² /W]	3.25	1.88	1.38	0.94	0.75

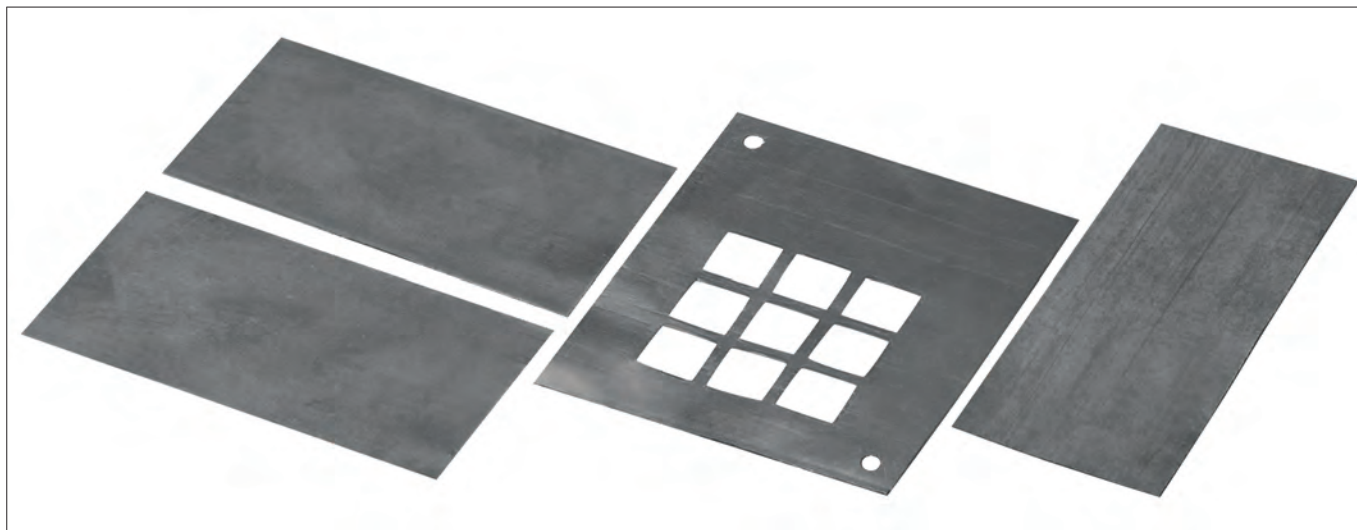

- high-compressed anisotropic natural graphite
- very good thermal characteristics
- optimal for heat spreading
- high operating temperature range
- tape width (B) available in different dimensions and lengths
- different material thicknesses and coatings upon request
- customer specified cuttings and stampings acc. to drawing

art. no.	B [mm]
WLFG S 900 R 25	25
WLFG S 900 R 50	50
WLFG S 900 R 100	100

WLFG S 900	
version	graphite foil, electrically conductive
version	without adhesive coating
material thickness	0.15 mm
colour	dark gray
density	> 1.6 g/cm ³
hardness	30 Shore D
thermal conductivity z (x/y)	7.5 (> 450) W/m·K
thermal resistance	0,08 K/W
specific thermal resistance	34°C mm ² /W
temperature range	-40°C... +500°C
tear strength	10 N/mm ²
elongation at break	5 %
class of inflammability	UL 94 V-0
type of delivery	sold by the meter
storage conditions	+18 °C - +28 °C/ 30 % - 70 % humidity
shelf life	almost unlimited

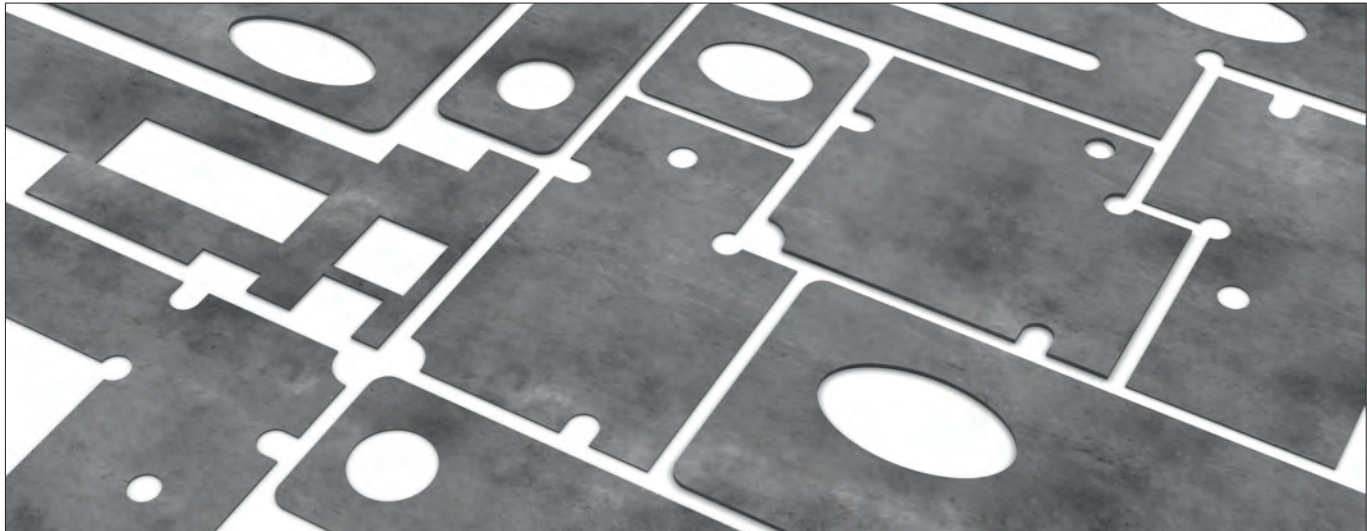

- highly thermally conductive graphite foil
- with and without adhesive coating
- very good temperature resistance
- ideally suited as a heat spreader
- customer-specific cuts and molded parts

art. no.	material thickness [mm]	art. no.	material thickness [mm]
WLFG 9813 R310	0.13	WLFG 9813 K R310	0.13
WLFG 9825 R310	0.25	WLFG 9825 K R310	0.25
WLFG 9850 R310	0.50	WLFG 9850 K R310	0.50
	WLFG 98 ...		WLFG 98 ... K
version	graphite foil, electrically conductive		
version	without adhesive coating	adherent layer on one side	
colour	grey		
hardness	85 Shore A		
thermal conductivity z (x/y)	8 (140) W/m·K		
temperature range	-240°C ... +350°C		
volume resistance	11·10 ⁻⁴ Ω·cm		
dielectric constant	<0,001 [1 MHz]		
class of inflammability	UL 94 V-0		
type of delivery	rolled goods, roll width 310mm/ other dimensions upon request/ sheet material upon request		
shelf life	16 months		

Thermal resistances vs. contact pressure / surface TO 220			
pressure [psi]	10	29	145
thermal impedance WLFG 9813 (K) R310 [K·cm ² /W]	0.77	0.58	0.39
thermal impedance WLFG 9825 (K) R310 [K·cm ² /W]	1.55	1.00	0.64
thermal impedance WLFG 9850 (K) R310 [K·cm ² /W]	2.60	1.48	1.00

Thermal conductive foil one-sided adhesive

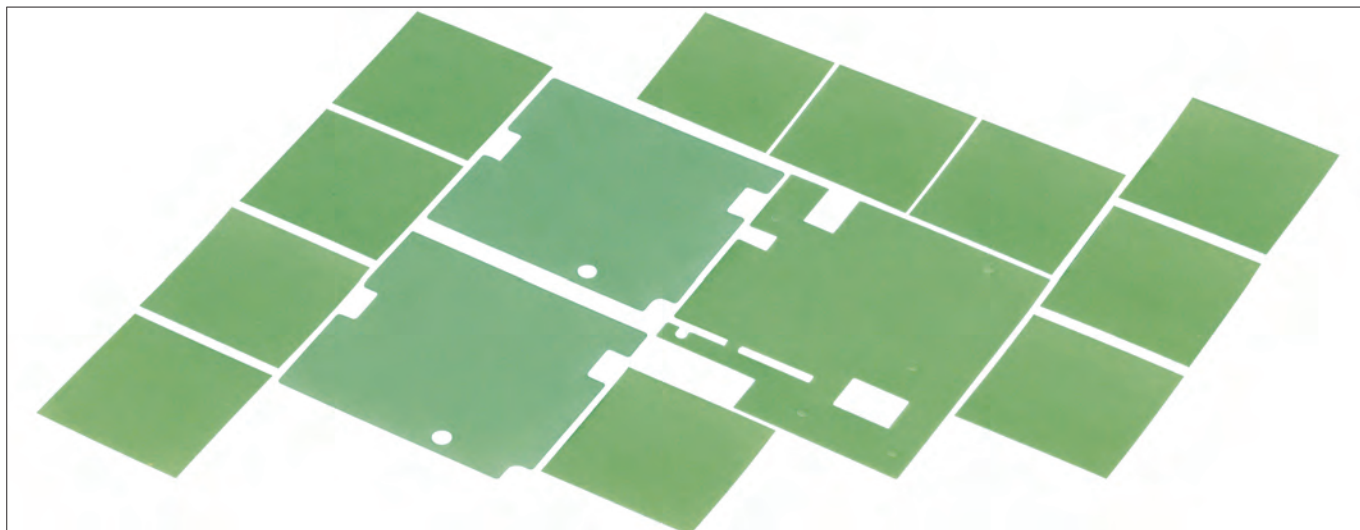

- one-side adhesive thermal conductive foil
- glass fibre reinforced design
- very good thermal conductivity
- simple handling and mounting
- cuts and contours according to customer's drawing specifications

art. no.	material thickness [mm]	
WLFT 30 015	0.15	
WLFT 30 023	0.23	
	WLFT 30 015	WLFT 30 023
version	silicone foil with glass fibre reinforcement	
colour	green	
hardness	80 Shore A	
thermal conductivity	3 W/m·K	
temperature range	-60°C ... +200°C	
elongation	5 %	
volume resistance	>10 ⁹ Ω·cm	
dielectric constant	6 [1 kHz]	
tear strength	1 N/mm ²	
dielectric strength	4 kV	6 kV
class of inflammability	UL 94 V-0	
type of delivery	plates, usable area 300x200mm/ other dimensions upon request	
storage conditions	+10 °C - +30 °C/ < 65 % humidity	
shelf life	12 months	



- one-sided adhesive thermal conductive foil
- additional fiberglass reinforcement
- high long-term and mechanical stability
- easy handling and mounting
- cuts and contours according to customer-specific drawing specifications

art. no.	material thickness [mm]
WLFT 40 023	0.23
	WLFT 40 023
version	silicone foil with glass fibre reinforcement
colour	white
hardness	90 Shore A
thermal conductivity	4 W/m·K
temperature range	-60°C ... +200°C
elongation	5 %
volume resistance	10·10 ¹¹ Ω·cm
dielectric constant	4.2 [1 MHz]
tear strength	4.9 N/mm ²
dielectric strength	6 kV
class of inflammability	UL 94 V-0
type of delivery	rolled goods, roll width 300mm/ cuttings on customer's requirement
storage conditions	+10 °C - +30 °C/ < 65 % humidity
shelf life	12 months

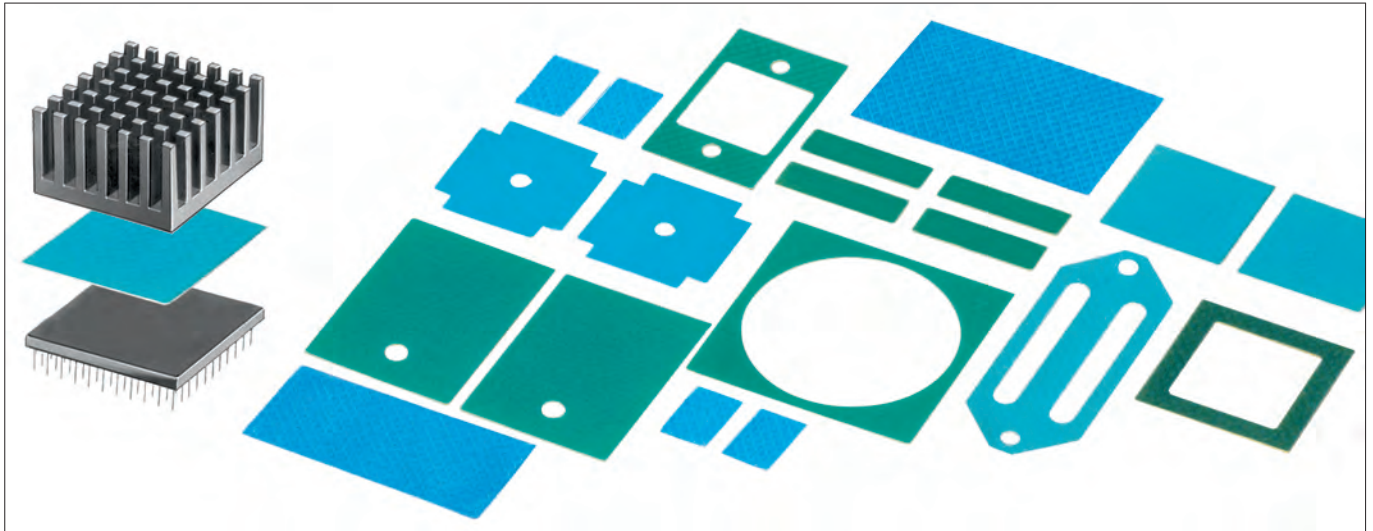
Thermally conductive foil both sides adhesive

- double-side adhesive thermal conductive foil with good thermal properties
- coated carrier film with pressure-sensitive acrylate adhesive
- curing of the adhesive layer can be influenced by temperature and time
- serves as a substitute for mechanical connections
- excellent adhesive properties on aluminium and ceramics
- simple and secure attachment of e.g. heatsinks to electronic devices
- designs as electrically conductive or electrically insulating thermal conductive foil
- supplied in sheet and tape form, other forms on request
- tape width (B) available in different dimensions and lengths
- 24h sample delivery service for individual production according to customer drawing
- customised cuts and contours according to drawing specifications

art. no.	B [mm]	type of delivery
WLFT 404 R25	25	sold by the meter
WLFT 404 R50	50	
WLFT 404 R100	100	
WLFT 404 R200	200	
WLFT 414 R25	25	
WLFT 414 R50	50	
WLFT 414 R100	100	
WLFT 414 R200	200	
WLFT 405 R25	25	
WLFT 405 R50	50	
WLFT 405 R100	100	
WLFT 405 R200	200	
WLFT 412 R25	25	
WLFT 412 R50	50	
WLFT 412 R100	100	
WLFT 412 R200	200	

art. no.	dimensions [mm]		type of delivery	
WLFT 404 100x100	100x100		plate	
WLFT 404 100x200	100x200			
WLFT 404 200x200	200x200			
WLFT 414 100x100	100x100			
WLFT 414 100x200	100x200			
WLFT 414 200x200	200x200			
WLFT 405 100x100	100x100			
WLFT 405 100x200	100x200			
WLFT 405 200x200	200x200			
WLFT 412 100x100	100x100			
WLFT 412 100x200	100x200			
WLFT 412 200x200	200x200			
	WLFT 404	WLFT 414		
version	insulating, double sided adhesive		non insulating, double-sided adhesive	
material thickness	0.127 mm ±0.03		0.15 mm ±0.03	0.23 mm ±0.025
material filling	polyimide (Kapton MT) 0.025mm		aluminium foil 0.05mm	aluminum mesh
glue layer	acrylate (pressure sensitive) double-sided			
colour	blue			grey
thermal conductivity	0,4 W/m·K		0,5 W/m·K	1,4 W/m·K
thermal impedance (@ 300 psi)	3.7 °C cm ² /W		3.4 °C cm ² /W	2 °C cm ² /W
holding force (overlapping)	0.86 MPa	0.69 MPa	0.93 MPa	
temperature range	-30°C... +125°C			
holding force (shear force)	Al 25°C 0.897 [MPa]/ Al 150°C 0.345 [MPa]/ Cu 25°C 0.828 [MPa]/ Cu 150°C 0.31 [MPa]/ Al₂O₃ 25°C 1.17 [MPa]/ Al₂O₃ 150°C 0.34 [MPa]	Al 25°C 1.04 [MPa]/ Al 150°C 0.104 [MPa]	Al 25°C 0.86 [MPa]/ Al 150°C 0.38 [MPa]/ Cu 25°C 1.1 [MPa]/ Cu 150°C 0.48 [MPa]/ Al₂O₃ 25°C 1.0 [MPa]/ Al₂O₃ 150°C 0.41 [MPa]	
dielectric strength	5 kV (AC)			
class of inflammability	UL 94 V-0			
storage conditions	+15 °C - +30 °C/ normal storage conditions			
shelf life	12 months			

Thermally conductive foil both sides adhesive

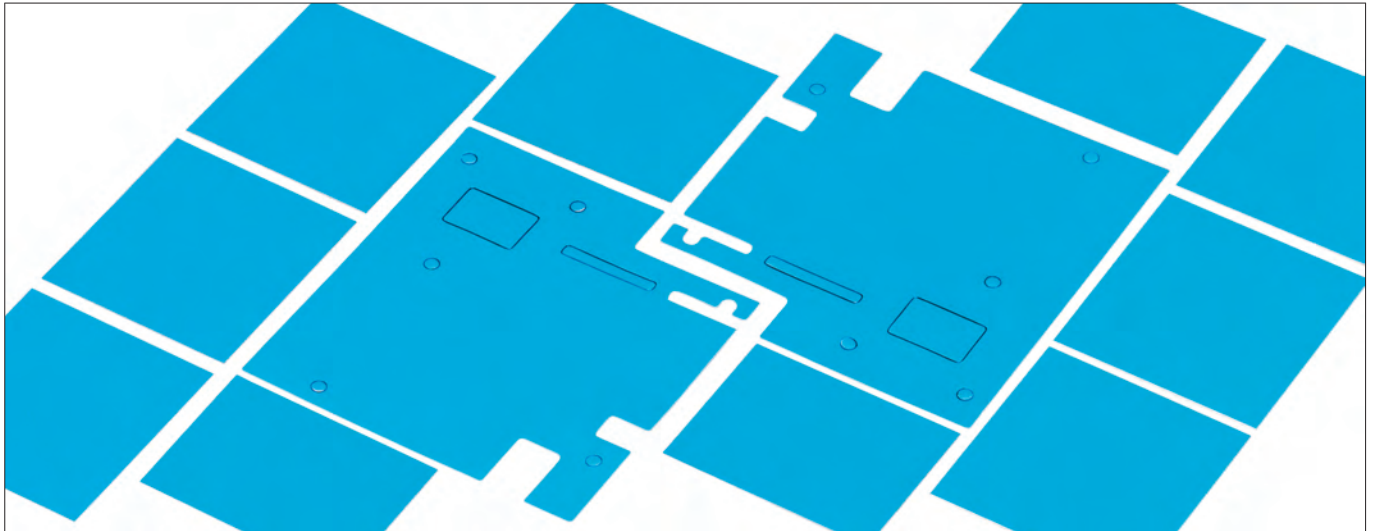

- double sided adhesive layer
- optimal adhesion of different substrates
- very good thermal conductivity, electrical insulating
- easy handling due to double sided protection foil
- optimized surface moistening and excellent impact strength
- cutouts and different punchings according to customer drawing

art. no.	type of delivery
WLFT 8805	plates, usable area 300x200mm/ other dimensions upon request
WLFT 8810	
WLFT 8815	
WLFT 8820	

	WLFT 8805	WLFT 8810	WLFT 8815	WLFT 8820
version	double sided adhesive, filled acrylic polymer			
material thickness	0.13 mm	0.25 mm	0.38 mm	0.5 mm
filling material	ceramic			
protection cover	silicone treated polyester, 37.5 - 50 μ m			
colour	blue			
thermal conductivity	0,6 W/m·K			
specific thermal resistance	3.2°C cm ² /W	5.8°C cm ² /W	7.7°C cm ² /W	9.7°C cm ² /W
temperature range	permanent up to 100°C			
peel strength at RT 70°C and 72 h	5.8 N/cm	8.3 N/cm	9.8 N/cm	11.9 N/cm
volume resistance	5.2·10 ¹¹ Ω /cm	3.9·10 ¹¹ Ω /cm	3.8·10 ¹¹ Ω /cm	
dielectric strength	26 kV/mm			
class of inflammability	UL 746 C			
storage conditions	+22 °C/ 50 % humidity			
shelf life	24 months			

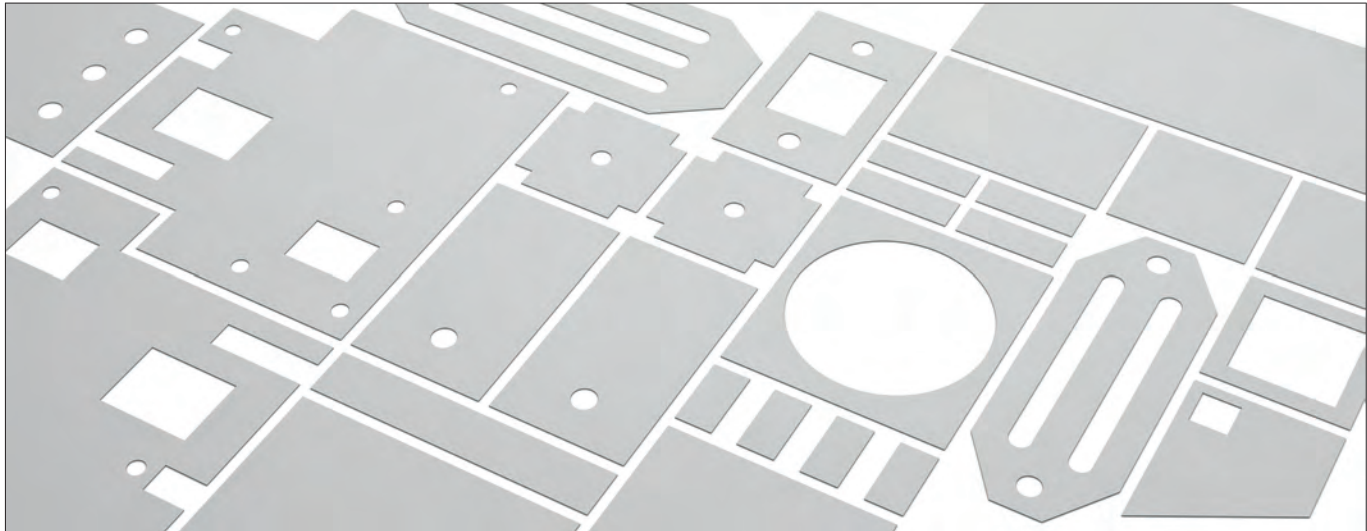

- double-sided adhesive thermal conductive foil
- excellent adhesive properties on different materials
- filling material with ceramic particles
- very good thermal conductivity and technical performance
- cuts and contours according to customer's drawing specifications

art. no.	type of delivery		
WLFT 8926 02	plates, usable area 300x200mm/ other dimensions upon request		
WLFT 8926 025			
WLFT 8926 05			
	WLFT 8926 02	WLFT 8926 025	WLFT 8926 05
version	double sided adhesive, filled acrylic polymer		
material thickness	0.2 mm	0.25 mm	0.5 mm
filling material	ceramic		
protection cover	silicone treated polyester		
colour	yellowish white		
thermal conductivity	1,5 W/m·K		
specific thermal resistance	8.49 °C cm ² /W	8.74°C cm ² /W	9.7°C cm ² /W
temperature range	permanent up to 80°C		
peel strength at RT 70°C and 72 h	15 N/cm		
dielectric strength	15 kV/mm		
class of inflammability	UL 94 V-0		
storage conditions	+21 °C/ 50 % humidity		
shelf life	12 months		

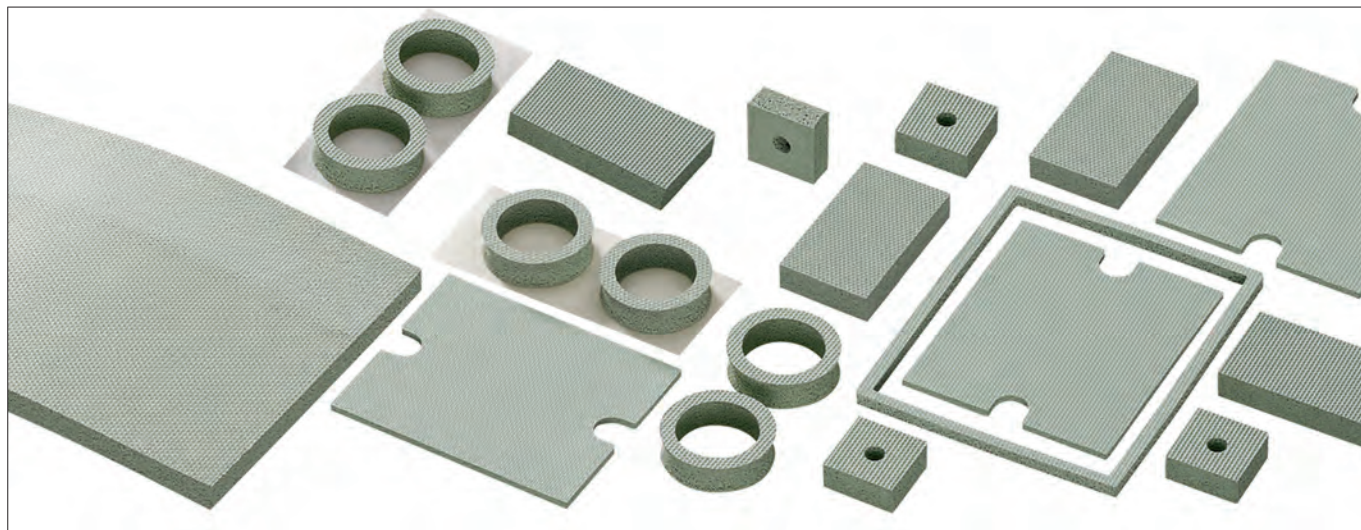

- elastomer foam with closed cell structure
- good heat conductor e.g. between components, heatsinks and casing parts
- electrical insulating
- can be compressed even with a low contact pressure
- absorbs shocks and vibrations

art. no.	material thickness [mm]
WSF 08	0.80 ±0.4
WSF 16	1.60 ±0.4
WSF 24	2.40 ±0.8
WSF 32	3.20 ±0.8
WSF 48	4.80 ±0.8
WSF 635	6.35 ±1.2
WSFS 635	

Thermal resistance at 3.2 mm material thickness:

compression [%]	10	30	50
contact pressure [psi]	5	20	42
R _{th} [K/W] (1 in ² x 3.2 mm)	13	9	3.5
heat conductivity [W/mK]	0.36	0.52	0.82

- **WSFS 635** double sided adhesive and **WSF** self-adhesive upon request
- according to NASA gas emission requirements

	WSF	WSFS 635
version	non adhesive	one-sided self-adhesive
colour	green	
density	1.105 g/cm ³	
hardness	13 Shore A	
temperature range	-62°C ... +205°C	
compression, 25%	18 psi	
elongation	150 %	
tear strength	120 psi	
dielectric strength	100 V/mm	
class of inflammability	UL 94 V-1 (at thickness ≥3.2mm)	
type of delivery	plates, usable area 914x914mm/ other dimensions upon request	
storage conditions	+21 °C/ 50 % humidity	
shelf life	120 months	6 months

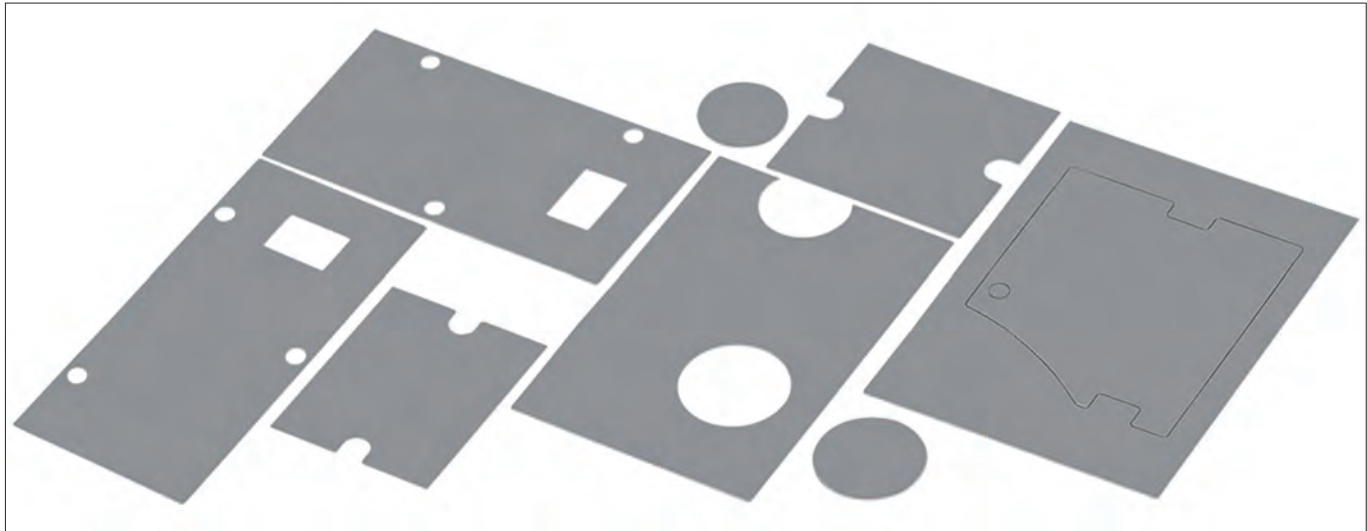

- silicone free gap-filler with good thermal characteristics
- smooth, compressible and elastic
- cut outs, punchings and modifications according to customer specification
- other material thicknesses upon request

art. no.	material thickness [mm]	R _{th} (100 kPa) [°C in ² /W]	R _{th} (100 kPa) [°C cm ² /W]	art. no.	material thickness [mm]	R _{th} (100 kPa) [°C in ² /W]	R _{th} (100 kPa) [°C cm ² /W]
GEL F 15 10	1.0 ±0.2	1.02	6.60	GEL F 15 G 10	1.0 ±0.2	1.16	7.50
GEL F 15 15	1.5 ±0.2	1.39	9.00	GEL F 15 G 15	1.5 ±0.2	1.66	10.75
GEL F 15 20	2.0 ±0.3	1.75	11.30	GEL F 15 G 20	2.0 ±0.3	2.17	14.00
	GEL F 15			GEL F 15 G			
version	standard			polyamide film mesh reinforced			
colour	light gray						
density	2.1 g/cm ³						
hardness	53 Shore 00						
thermal conductivity	1,5 W/m·K						
temperature range	-40°C... +105°C						
elongation	150 %						
volume resistance	1·10 ⁹ Ω·m						
dielectric constant	9.12 [50 Hz] / 8.55 [1 kHz] / 5.83 [1 MHz]						
dielectric loss factor	0.152 [50 Hz] / 0.135 [1 kHz] / 0.034 [1 MHz]						
dielectric strength	11 kV/mm						
class of inflammability	accordant UL 94 V-0						
type of delivery	on both sides covered with protective foil/ plates, usable area 300x200mm/ other dimensions upon request						
storage conditions	-20 °C - +50 °C/ 45 % - 85 % humidity						
shelf life	12 months						

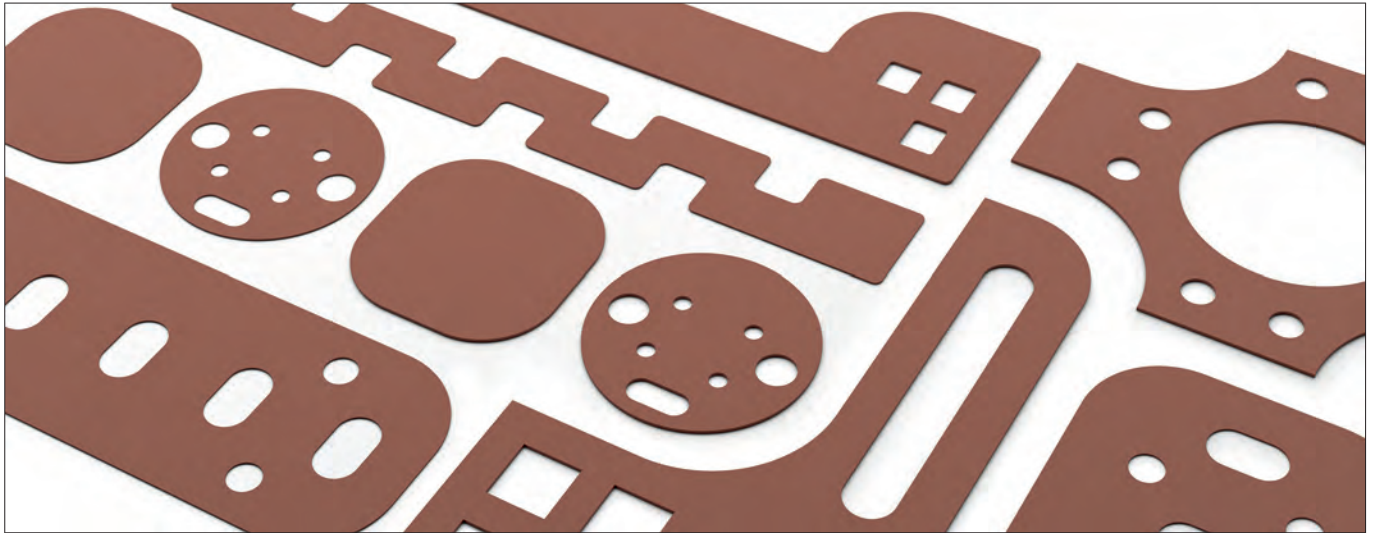

- silicone-free thermal conductive foil
- particularly suitable for silicone-free applications
- very good thermal and mechanical properties
- high electrical insulation
- cut to size and contours according to customised drawing specifications

art. no.	material thickness [mm]
GEL F 20 05	0.5
GEL F 20 10	1.0
GEL F 20	
version	silicone-free foil without glass fibre reinforcement
colour	brown
density	1.87 g/cm ³
hardness	60 - 75 Shore 00
thermal conductivity	2 W/m·K
thermal resistance	1.2 K/W
temperature range	-40°C ... +110°C
dielectric strength	8 kV
class of inflammability	UL 94 V-0
type of delivery	plates, usable area 450x250mm/ other dimensions upon request
storage conditions	+18 °C - +28 °C/ 30 % - 70 % humidity
shelf life	almost unlimited



- soft and adaptable acrylic-based thermal conductive foil
- very good compensation of unevennesses and differences in components
- natural adhesive properties and high dielectric strength
- cuts and contours with cutouts according to customer drawings

art. no.	material thickness [mm]
GEL F 30 05	0.5
GEL F 30 10	1.0
GEL F 30 15	1.5
GEL F 30 ...	
version	silicone-free thermal conductive foils
colour	white-grey
density	2.1 g/cm ³
hardness	70 Shore 00
thermal conductivity	3 W/m·K
temperature range	-40°C ... +110°C
volume resistance	6·10 ⁹ Ω·m
dielectric constant	5.4 [1 GHz]
dielectric strength	12 kV/mm
class of inflammability	UL 94 V-0
type of delivery	plates, usable area 240x300mm/ other dimensions upon request
storage conditions	+21 °C/ 50 % humidity
shelf life	24 months



- highly thermally conductive silicone foil; soft, elastic and compressible
- design with hardened surface on one side for better handling; optimum compensation of air gaps and unevennesses
- customised contour parts according to drawing specifications

art. no.	material thickness [mm]	R _{th} (100 kPa) [°C in ² /W]	R _{th} (100 kPa) [°C cm ² /W]	art. no.	material thickness [mm]	R _{th} (100 kPa) [°C in ² /W]	R _{th} (100 kPa) [°C cm ² /W]
GEL 14 05	0.5 ±0.15	0.60	3.9	GEL 14 G 05	0.5 ±0.15	0.64	4.1
GEL 14 10	1.0 ±0.20	0.90	5.8	GEL 14 G 10	1.0 ±0.20	0.99	6.4
GEL 14 15	1.5 ±0.20	1.13	7.3	GEL 14 G 15	1.5 ±0.20	1.35	8.7
GEL 14 20	2.0 ±0.30	1.55	10.0	GEL 14 G 20	2.0 ±0.30	1.69	10.9
GEL 14 25	2.5 ±0.30	1.84	11.9	GEL 14 G 25	2.5 ±0.30	2.03	13.1
GEL 14 30	3.0 ±0.30	1.92	12.4	GEL 14 G 30	3.0 ±0.30	2.09	13.5
GEL 14 35	3.5 ±0.35	2.30	15.0	GEL 14 G 35	3.5 ±0.35	2.45	15.5
GEL 14 40	4.0 ±0.40	2.65	17.1	GEL 14 G 40	4.0 ±0.40	2.74	17.7
GEL 14 45	4.5 ±0.45	2.75	17.8	GEL 14 G 45	4.5 ±0.45	3.05	19.5
GEL 14 50	5.0 ±0.50	2.81	18.1	GEL 14 G 50	5.0 ±0.50	3.30	21.3

	GEL 14	GEL 14 G
version	standard	surface hardened on one side
colour	pink	
hardness	30 Shore 00	
thermal conductivity	1,4 W/m·K	
temperature range	-40°C... +150°C	
volume resistance	2.4·10 ¹¹ Ω·m	
dielectric constant	5 [50 Hz] / 4.4 [1 kHz] / 4.2 [1 MHz]	
dielectric loss factor	0.095 [50 Hz] / 0.042 [1 kHz] / 0.004 [1 MHz]	
dielectric strength	17 kV/mm	
class of inflammability	UL 94 V-0	
type of delivery	plates, usable area 300x200mm/ other dimensions upon request	
storage conditions	-20 °C - +50 °C/ 45 % - 85 % humidity	
shelf life	12 months	

GEL 14 ... compression force [N/6,4cm ²] vs. material thickness								
material thickness [mm]	0,5	1,0	1,5	2,0	2,5	3,0	4,0	5,0
compression rate 10%	109	130	116	79	57	43	32	24
compression rate 30%	392	351	240	180	128	109	87	71
compression rate 50%	752	660	523	442	317	297	216	182

GEL 14 G ... compression force [N/6,4cm ²] vs. material thickness								
material thickness [mm]	0,5	1,0	1,5	2,0	2,5	3,0	4,0	5,0
compression rate 10%	106	145	144	98	64	51	38	25
compression rate 30%	524	428	258	222	165	135	105	80
compression rate 50%	867	805	580	526	406	341	260	209

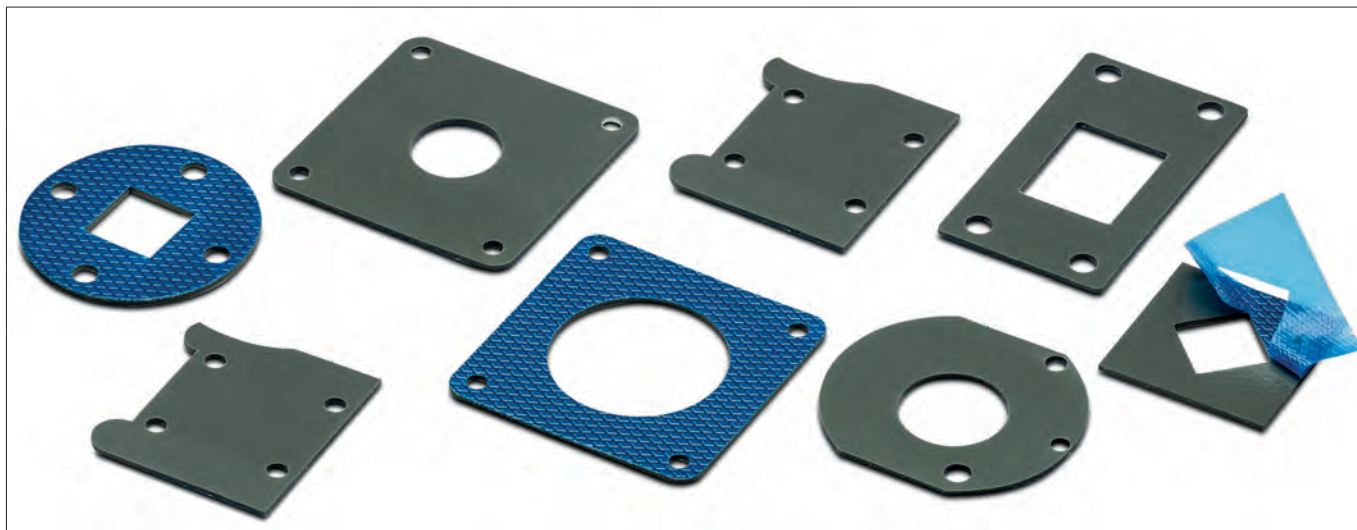

- very soft thermal conductive foil
- without any reinforcing layer
- optimal balance of bigger unevennesses
- thermal conductive foil both-sided adherent
- cuts and contours according to customer specific drawing specifications

art. no.	material thickness [mm]	art. no.	material thickness [mm]
WFG 15 05	0.508	WFG 15 25	2.540
WFG 15 10	1.016	WFG 15 30	3.175
WFG 15 15	1.524	WFG 15 40	4.064
WFG 15 20	2.032	WFG 15 50	5.080

WFG 15	
version	silicone film without reinforcement
colour	black
hardness	40 Shore 00
thermal conductivity	1,5 W/m·K
temperature range	-60°C ... +200°C
volume resistance	10 ¹¹ Ω·m
dielectric constant	5.5 [1 kHz]
heat capacity	1 J/g·K
dielectric strength	6 kV
class of inflammability	UL 94 V-0
type of delivery	plates, usable area 406x203mm/ other dimensions upon request
storage conditions	-20 °C - +50 °C/ 50 % humidity
shelf life	6 months

Thermal resistances vs. material thickness								
material thicknesses [mm]	0.508	1.016	1.524	2.032	2.540	3.175	4.064	5.08
thermal impedance WFG 15 [K·cm ² /W]	3	7.5	10	13.13	16.25	21.25	26.25	33.125

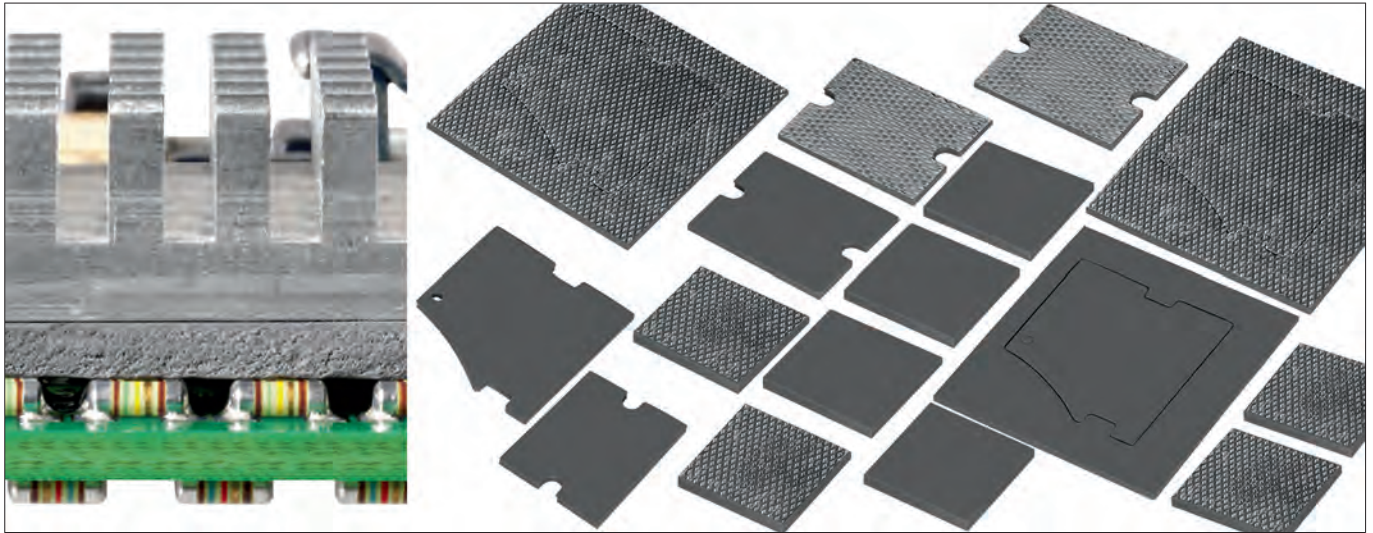

- GEL thermal conductive foils with very good thermal characteristics
- for balancing non-planarities and differences in components (gap-filler)
- soft, elastic and compressible
- customer specific cuts and punchings according to drawing

art. no.	material thickness [mm]	R _{th} (100 kPa) [°C in ² /W]	R _{th} (100 kPa) [°C cm ² /W]	art. no.	material thickness [mm]	R _{th} (100 kPa) [°C in ² /W]	R _{th} (100 kPa) [°C cm ² /W]
GEL 28 05	0,5 ±0.05	0,31	2,00	GEL 28 G 05	0,5 ±0.05	0,38	2,50
GEL 28 10	1,0 ±0.10	0,57	3,70	GEL 28 G 10	1,0 ±0.10	0,62	4,00
GEL 28 15	1,5 ±0.15	0,79	5,10	GEL 28 G 15	1,5 ±0.15	0,93	6,00
GEL 28 20	2,0 ±0.20	1,03	6,70	GEL 28 G 20	2,0 ±0.20	1,25	8,10
GEL 28 25	2,5 ±0.25	1,16	7,50	GEL 28 G 25	2,5 ±0.25	1,42	9,15
GEL 28 30	3,0 ±0.30	1,42	9,20	GEL 28 G 30	3,0 ±0.30	1,59	10,20
GEL 28 35	3,5 ±0.30	1,60	10,40	GEL 28 G 35	3,5 ±0.30	1,87	12,05
GEL 28 40	4,0 ±0.30	1,79	11,60	GEL 28 G 40	4,0 ±0.30	2,16	13,90
GEL 28 50	5,0 ±0.30	2,16	13,90	GEL 28 G 50	5,0 ±0.30	2,48	16,00

	GEL 28	GEL 28 G
version	standard	surface hardened on one side
colour	grey	
density	2.6 g/cm ³	
hardness	50 Shore 00	55 Shore 00
thermal conductivity	2,5 W/m·K	
temperature range	-40°C... +150°C	
elongation	64 %	32 %
volume resistance	1·10 ¹¹ Ω·m	
dielectric constant	6.6 [50 Hz]/6.05 [1 kHz]/5.74 [1 MHz]	
dielectric loss factor	0.0826 [50 Hz]/0.0300 [1 kHz]/0.0052 [1 MHz]	
dielectric strength	15 kV/mm	
class of inflammability	UL 94 V-0	
type of delivery	on both sides covered with protective foil/ plates, usable area 300x200mm/ other dimensions upon request	
storage conditions	-20 °C - +50 °C/ 45 % - 85 % humidity	
shelf life	12 months	

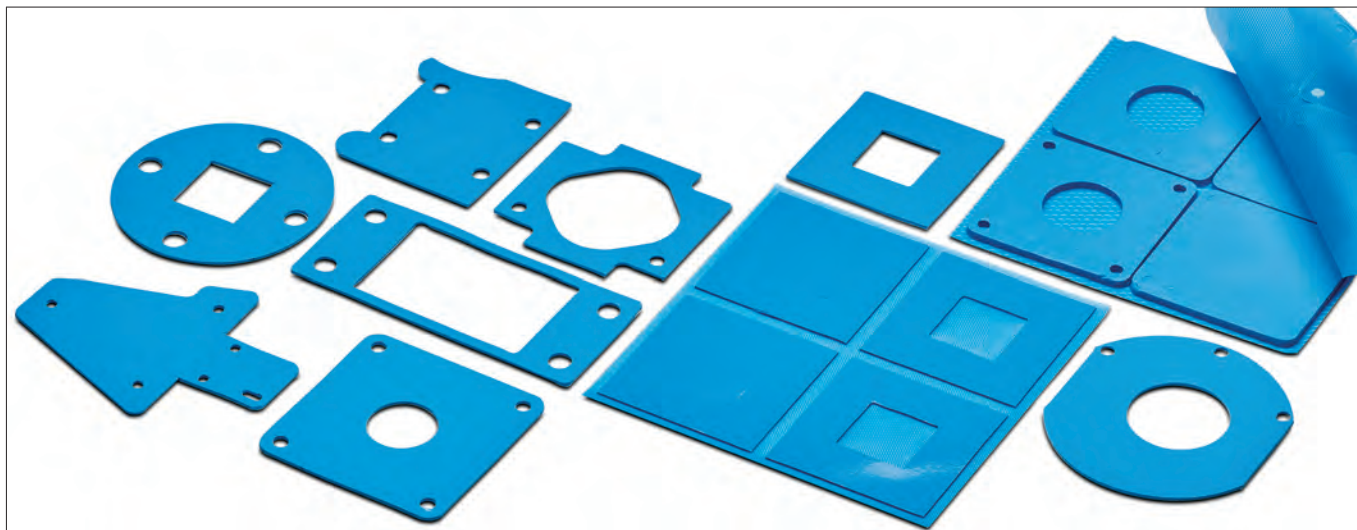

- good compressible gap filling material
- high thermal conductivity
- very good shearing and tensile strength
- double-sided natural adhesive layer
- cuts and contours according to customer specific drawing specifications

art. no.	material thickness [mm]	art. no.	material thickness [mm]
WFGH 30 05	0.508	WFGH 30 20	2.032
WFGH 30 10	1.016	WFGH 30 25	2.540
WFGH 30 15	1.524	WFGH 30 30	3.175

WFGH 30	
version	silicone foil with glass fibre reinforcement
colour	blue
hardness	15 Shore 00
thermal conductivity	3 W/m·K
temperature range	-60°C ... +200°C
volume resistance	10 ¹⁰ Ω·m
dielectric constant	6.5 [1 kHz]
heat capacity	1 J/g·K
dielectric strength	5 kV
class of inflammability	UL 94 V-0
type of delivery	plates, usable area 406x203mm/ other dimensions upon request
storage conditions	-20 °C - +50 °C/ 50 % humidity
shelf life	12 months

Thermal resistances vs. material thickness						
material thicknesses [mm]	0.508	1.016	1.524	2.032	2.540	3.175
thermal impedance WFGH 30 [K·cm ² /W]	1.88	3.75	5	6.88	8.13	10.93

- heat conducting film with very good thermal properties
- optimum adaptability with little effort
- surfaces with high adhesive strength
- additional glass fibre reinforcement for demanding applications
- cuts and individual moulded parts according to customer-specific drawing specifications
- 24-hour sample delivery service for heat conducting foils

art. no.	material thickness [mm]	art. no.	material thickness [mm]
GEL 32 A 05	0.5	GEL 32 A 20	2.0
GEL 32 A 10	1.0	GEL 32 A 25	2.5
GEL 32 A 15	1.5	GEL 32 A 30	3.0

GEL 32 A	
version	silicone foil with glass fibre reinforcement
colour	blue
hardness	38 Shore 00
thermal conductivity	3,2 W/m·K
temperature range	-55°C ... +200°C
volume resistance	1·10 ¹¹ Ω·m
dielectric constant	8 [1 MHz]
dielectric strength	6.7 kV/mm
class of inflammability	UL 94 V-0
type of delivery	plates, usable area 457x457 mm/ other dimensions upon request
storage conditions	+10 °C - +32 °C/ 50 % humidity
shelf life	36 months

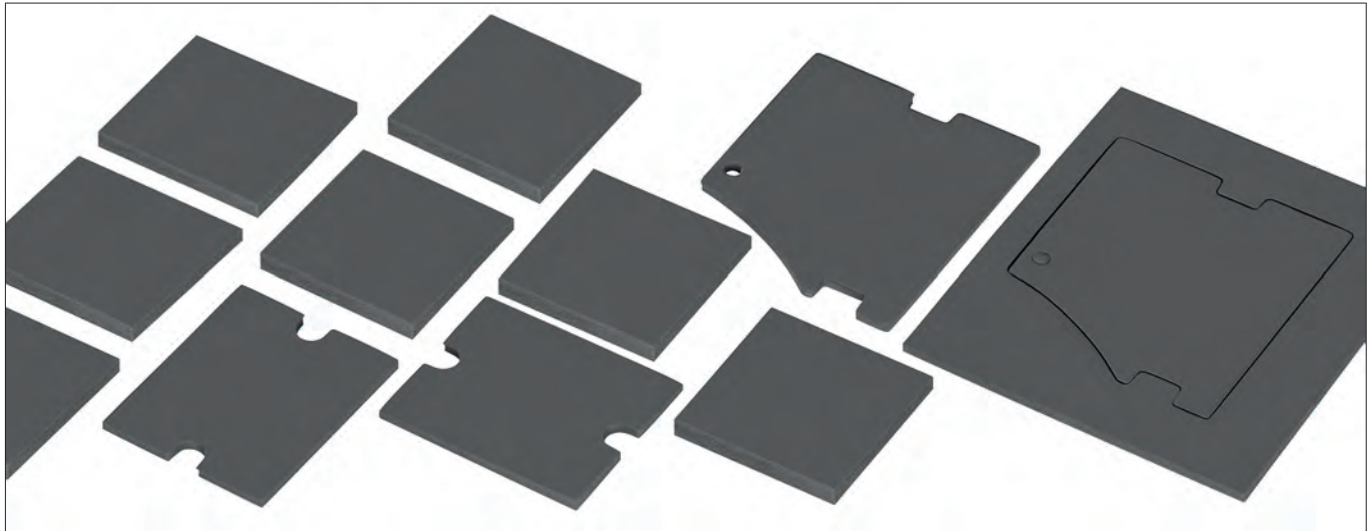

- gap filler with exceptionally good thermal conductivity and low outgassing
- especially smooth, compressible and elastic
- cut outs, punchings and modifications according to customer specification
- other material thicknesses upon request

art. no.	material thickness [mm]	R _{th} (100 kPa) [°C in ² /W]	R _{th} (100 kPa) [°C cm ² /W]	art. no.	material thickness [mm]	R _{th} (100 kPa) [°C in ² /W]	R _{th} (100 kPa) [°C cm ² /W]
GEL 45 05	0.5 ±0.15	0.28	1.80	GEL 45 G 05	0.5 ±0.15	0.22	1.40
GEL 45 10	1.0 ±0.20	0.37	2.40	GEL 45 G 10	1.0 ±0.20	0.35	2.30
GEL 45 15	1.5 ±0.20	0.46	2.90	GEL 45 G 15	1.5 ±0.20	0.45	2.90
GEL 45 20	2.0 ±0.30	0.56	3.60	GEL 45 G 20	2.0 ±0.30	0.55	3.60
GEL 45 25	2.5 ±0.30	0.68	4.40	GEL 45 G 25	2.5 ±0.30	0.62	4.00
GEL 45 30	3.0 ±0.30	0.79	5.10	GEL 45 G 30	3.0 ±0.30	0.73	4.70
GEL 45 35	3.5 ±0.35	0.87	5.65	GEL 45 G 35	3.5 ±0.35	0.83	5.35
GEL 45 40	4.0 ±0.40	0.95	6.20	GEL 45 G 40	4.0 ±0.40	0.93	6.00
GEL 45 45	4.5 ±0.45	1.04	6.80	GEL 45 G 45	4.5 ±0.45	1.00	6.45
GEL 45 50	5.0 ±0.50	1.14	7.40	GEL 45 G 50	5.0 ±0.50	1.07	6.90

	GEL 45	GEL 45 G
version	standard	surface hardened on one side
colour	grey	
density	3.2 g/cm ³	
hardness	60 Shore 00	
thermal conductivity	4,5 W/m·K	
temperature range	-40°C... +150°C	
elongation	50 %	
volume resistance	1·10 ¹¹ Ω·m	
dielectric constant	8.98 [50 Hz] / 8.63 [1 kHz] / 8.05 [1 MHz]	
dielectric loss factor	0.0249 [50 Hz] / 0.0219 [1 kHz] / 0.0068 [1 MHz]	
dielectric strength	17 kV/mm	
class of inflammability	UL 94 V-0	
type of delivery	on both sides covered with protective foil/ plates, usable area 300x200mm/ other dimensions upon request	
storage conditions	-20 °C - +50 °C/ 45 % - 85 % humidity	
shelf life	12 months	

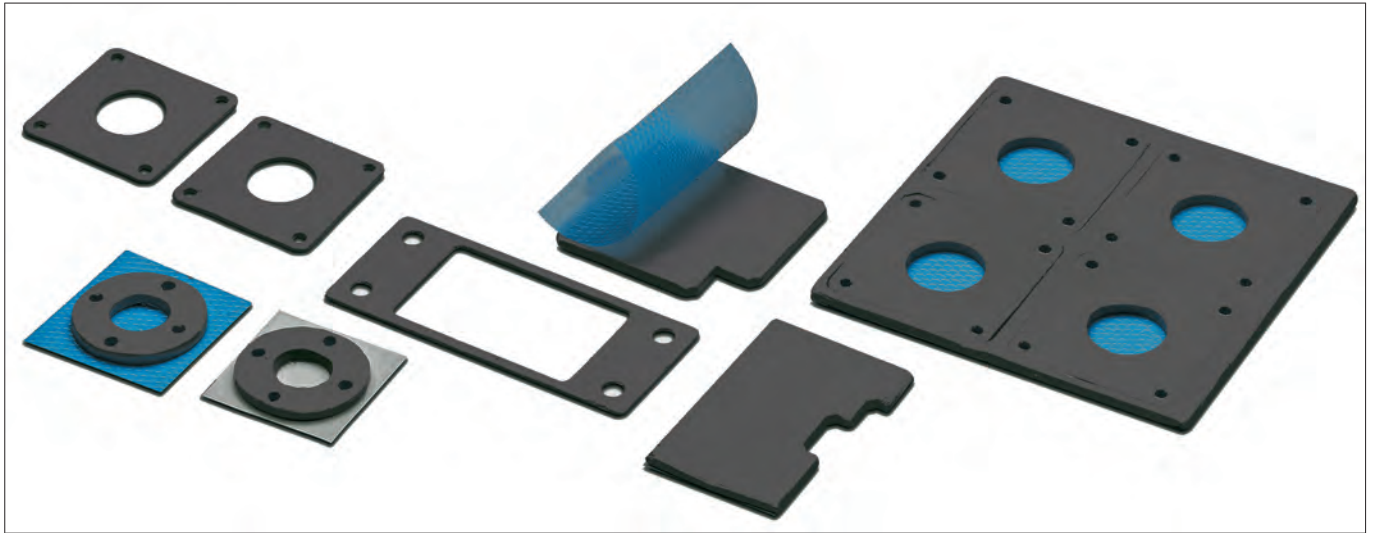

- very good compressibility
- particularly suitable for low contact pressure
- double-sided natural adhesive layer
- wide temperature range
- cut to size and contours according to customised drawing specifications

art. no.	material thickness [mm]	art. no.	material thickness [mm]
WFGH 50 05	0.508	WFGH 50 20	2.032
WFGH 50 10	1.016	WFGH 50 25	2.540
WFGH 50 15	1.524	WFGH 50 30	3.175

WFGH 50	
version	silicone foil with glass fibre reinforcement
colour	grey
hardness	35 Shore 00
thermal conductivity	5 W/m·K
temperature range	-60°C ... +200°C
volume resistance	10 ¹⁰ Ω·m
dielectric constant	8 [1 kHz]
heat capacity	1 J/g·K
dielectric strength	5 kV
class of inflammability	UL 94 V-0
type of delivery	plates, usable area 406x203mm/ other dimensions upon request
storage conditions	-20 °C - +50 °C/ 50 % humidity
shelf life	12 months

Thermal resistances vs. material thickness						
material thicknesses [mm]	0.508	1.016	1.524	2.032	2.540	3.175
thermal impedance WFGH 50 [K·cm ² /W]	1.25	2.5	3.75	5.18	6.25	8.13

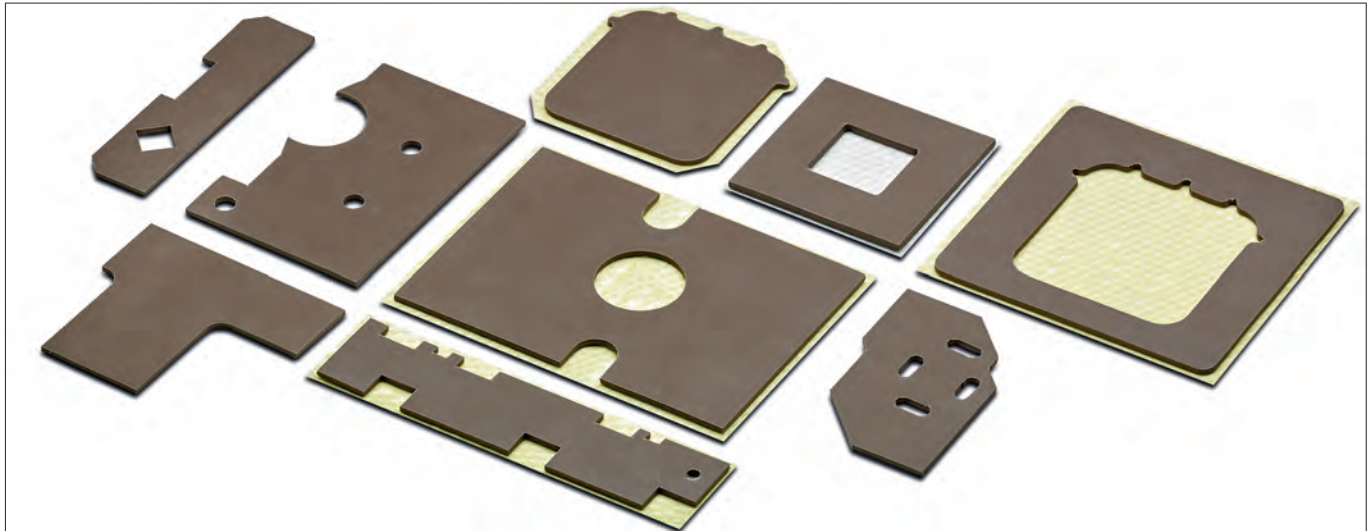

- GEL silicone foils with especially high thermal conductivity
- balances non-planarities and differences in components (Gap filler)
- soft, elastic and compressible
- cuts, punchings and special designs according to customer specifications

art. no.	material thickness [mm]	R _{th} (100 kPa) [°C in ² /W]	R _{th} (100 kPa) [°C cm ² /W]	art. no.	material thickness [mm]	R _{th} (100 kPa) [°C in ² /W]	R _{th} (100 kPa) [°C cm ² /W]
GEL 60 05	0.5 ±0.1	0.21	1.30	GEL 60 G 05	0.5 ±0.1	0.27	1.68
GEL 60 10	1.0 ±0.2	0.32	2.11	GEL 60 G 10	1.0 ±0.2	0.45	2.80
GEL 60 15	1.5 ±0.2	0.53	3.45	GEL 60 G 15	1.5 ±0.2	0.60	3.72
GEL 60 20	2.0 ±0.3	0.64	3.97	GEL 60 G 20	2.0 ±0.3	0.75	4.65
GEL 60 25	2.5 ±0.3	0.72	4.67	GEL 60 G 25	2.5 ±0.3	0.90	5.58
		GEL 60				GEL 60 G	
version		standard				polyamide film mash reinforced	
colour		dark reddish grey					
density		3.2 g/cm ³					
hardness		52 Shore 00					
thermal conductivity		6 W/m·K					
temperature range		-60°C ... +200°C					
elongation		80 %					
volume resistance		1,3·10 ¹² Ω·m					
dielectric constant		6.4 [50 Hz]/6.4 [1 kHz]/6.4 [1 MHz]					
dielectric loss factor		0.035 [50 Hz]/0.005 [1 kHz]/0.001 [1 MHz]					
dielectric strength		13 kV/mm					
class of inflammability		UL 94 V-0					
type of delivery		on both sides covered with protective foil/ plates, usable area 300x200mm/ other dimensions upon request					
storage conditions		-20 °C - +50 °C/ 45 % - 85 % humidity					
shelf life		12 months					

- excellent thermal conductivity
- soft and very mouldable
- low outgassing properties
- very good mechanical damping properties
- parts according to drawing and cut-to-size parts according to customer specifications
- 24-hour sample delivery service for thermally conductive foils

art. no.	material thickness [mm]	art. no.	material thickness [mm]
GEL 60 A 05	0.5	GEL 60 A 20	2.0
GEL 60 A 10	1.0	GEL 60 A 25	2.5
GEL 60 A 15	1.5	GEL 60 A 30	3.0

GEL 60 A	
version	silicone film without reinforcement
colour	green
hardness	31 Shore 00
thermal conductivity	6 W/m·K
temperature range	-55°C ... +200°C
volume resistance	1·10 ¹¹ Ω·m
dielectric constant	9.3 [1 MHz]
dielectric strength	5 kV/mm
class of inflammability	UL 94 V-0
type of delivery	plates, usable area 254x381mm/ other dimensions upon request
storage conditions	+10 °C - +32 °C/ 50 % humidity
shelf life	36 months

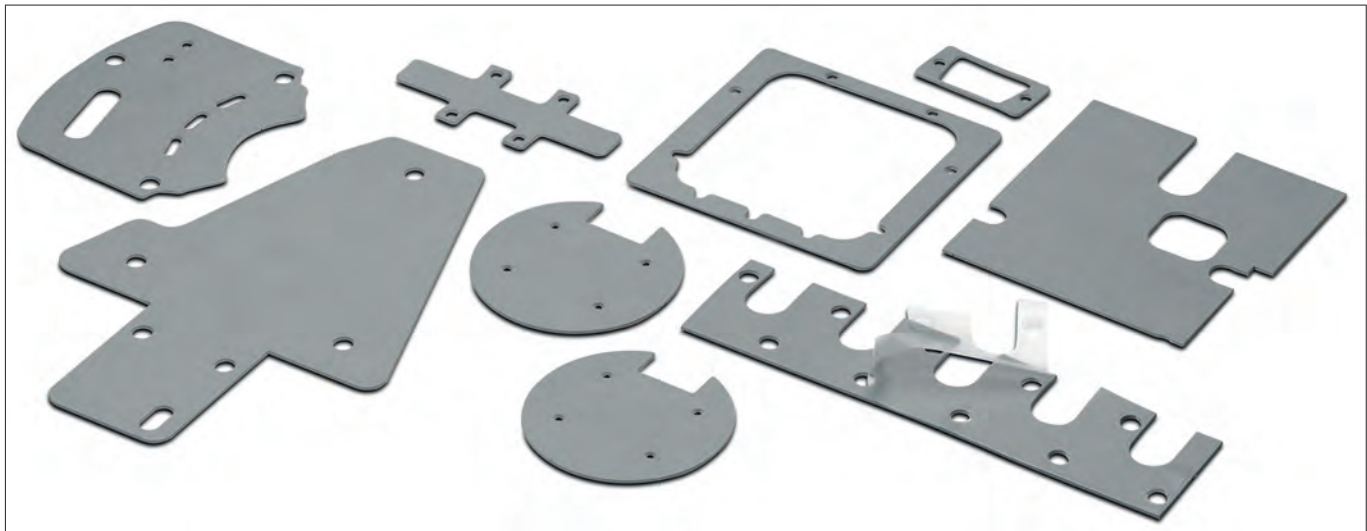

- high heat conducting silicone foil as a gap-filler
- very good compression with high dielectric strength
- optimal for balancing big unevennesses or production tolerances
- customer specific cuts according to drawing
- other material compositions and thicknesses upon request

art. no.	material thickness [mm]	R _{th} (100 kPa) [°C in ² /W]	R _{th} (100 kPa) [°C cm ² /W]	art. no.	material thickness [mm]	R _{th} (100 kPa) [°C in ² /W]	R _{th} (100 kPa) [°C cm ² /W]
GEL 80 10	1.0 ±0.15	0.17	1.10	GEL 80 G 05	0.5 ±0.10	0.12	0.77
GEL 80 15	1.5 ±0.20	0.26	1.68	GEL 80 G 10	1.0 ±0.15	0.19	1.22
GEL 80 20	2.0 ±0.30	0.36	2.32	GEL 80 G 15	1.5 ±0.20	0.28	1.81
GEL 80 25	2.5 ±0.30	0.45	2.91	GEL 80 G 20	2.0 ±0.30	0.38	2.45
GEL 80 30	3.0 ±0.30	0.57	3.68	GEL 80 G 25	2.5 ±0.30	0.47	3.01
GEL 80 G 03	0.3 ±0.06	0.09	0.58	GEL 80 G 30	3.0 ±0.30	0.59	3.49

	GEL 80	GEL 80 G
version	standard	surface hardened on one side
colour	grey	
density	3.3 g/cm ³	
hardness	67 Shore 00	
thermal conductivity	8 W/m·K	
temperature range	-40°C... +150°C	
elongation	50 %	
volume resistance	3·10 ¹¹ Ω·m	
dielectric constant	9.54 [50 Hz] / 8.82 [1 kHz] / 7.92 [1 MHz]	
dielectric loss factor	0.063 [50 Hz] / 0.044 [1 kHz] / 0.014 [1 MHz]	
dielectric strength	12 kV/mm	
class of inflammability	UL 94 V-0	
type of delivery	on both sides covered with protective foil/ plates, usable area 300x200mm/ other dimensions upon request	
storage conditions	-20 °C - +50 °C/ 45 % - 85 % humidity	
shelf life	12 months	

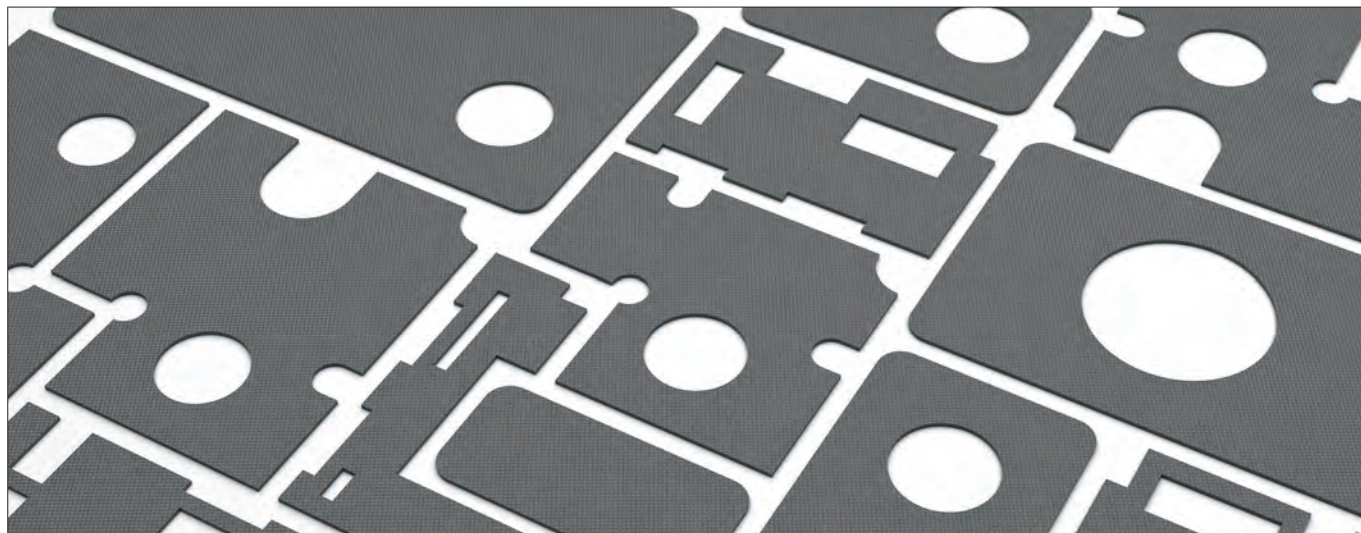

- very good thermal conductivity and insulation properties
- simple pre-assembly due to self-adhesion
- residue-free removal after application
- outgassing properties comply with NASA requirements
- cuts and contours with openings made of sheet material

art. no.	material thickness [mm]	art. no.	material thickness [mm]
GEL 83 A 05	0.5	GEL 83 A 20	2.0
GEL 83 A 10	1.0	GEL 83 A 25	2.5
GEL 83 A 15	1.5	GEL 83 A 30	3.0

GEL 83 A	
version	silicone foil with glass fibre reinforcement
colour	dark gray
hardness	35 Shore 00
thermal conductivity	8,3 W/m·K
temperature range	-55°C ... +200°C
volume resistance	1·10 ¹² Ω·m
dielectric constant	6 [1 MHz]
dielectric strength	5 kV/mm
class of inflammability	UL 94 V-0
type of delivery	plates, usable area 457x457 mm/ other dimensions upon request
storage conditions	+10 °C - +32 °C/ 50 % humidity
shelf life	36 months



- gap filler with exceptionally good thermal conductivity and low outgassing
- especially smooth, compressible and elastic
- cut outs, punchings and modifications according to customer specification
- other material thicknesses upon request

art. no.	material thickness [mm]	R _{th} (100 kPa) [°C in ² /W]	R _{th} (100 kPa) [°C cm ² /W]	art. no.	material thickness [mm]	R _{th} (100 kPa) [°C in ² /W]	R _{th} (100 kPa) [°C cm ² /W]
GEL 100 10	1.0 ±0.20	0.13	0.84	GEL 100 G 05	0.5 ±0.15	0.11	0.68
GEL 100 15	1.5 ±0.20	0.16	1.06	GEL 100 G 10	1.0 ±0.20	0.15	0.97
GEL 100 20	2.0 ±0.30	0.24	1.56	GEL 100 G 15	1.5 ±0.20	0.21	1.36
GEL 100 G 03	0.3 ±0.06	0.09	0.61	GEL 100 G 20	2.0 ±0.30	0.25	1.60
		GEL 100				GEL 100 G	
version	standard with double-sided adhesive surface			surface hardened on one side			
colour	pink						
density	3.2 g/cm ³						
hardness	50 Shore 00						
thermal conductivity	10 W/m·K						
temperature range	-40°C... +150°C						
volume resistance	3·10 ¹¹ Ω·m						
dielectric constant	11.4 [50 Hz] / 9.6 [1 kHz] / 8.4 [1 MHz]						
dielectric loss factor	0.372 [50 Hz] / 0.070 [1 kHz] / 0.024 [1 MHz]						
dielectric strength	10 kV/mm						
class of inflammability	UL 94 V-0						
type of delivery	on both sides covered with protective foil/ plates, usable area 300x200mm/ other dimensions upon request						
storage conditions	-20 °C - +50 °C/ 45 % - 85 % humidity						
shelf life	12 months						

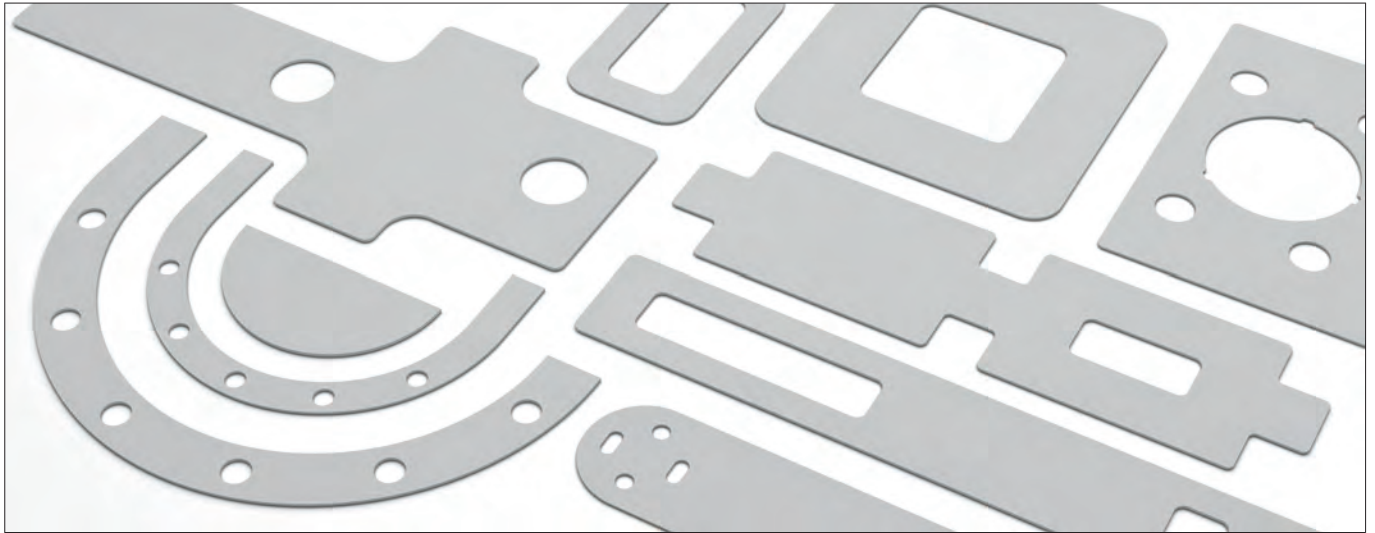

- besonders hohe Wärmeleitfähigkeit
- passen sich sehr gut an unebene Oberflächen an
- hohe Anpassungsfähigkeit, doppelseitige Klebefläche zur einfachen Handhabung
- Zuschnitte, Ausstanzungen und Sonderausführungen nach Kundenangaben

art. no.	material thickness [mm]	R_{th} (100 kPa) [°C in ² /W]	R_{th} (100 kPa) [°C cm ² /W]
GEL 130 03	0.3 ±0.06	0.04	0.3
GEL 130 05	0.5 ±0.10	0.06	0.4
GEL 130 10	1.0 ±0.15	0.11	0.7
GEL 130 15	1.5 ±0.20	0.16	1.0
GEL 130 20	2.0 ±0.30	0.20	1.3

	GEL
version	standard with double-sided adhesive surface
colour	light gray
density	3 g/cm ³
hardness	74 Shore 00
thermal conductivity	13 W/m·K
temperature range	-40°C... +150°C
volume resistance	1·10 ¹⁰ Ω·m
dielectric constant	9.44 [50 Hz] / 8.47 [1 kHz] / 7.97 [1 MHz]
dielectric loss factor	0.157 [50 Hz] / 0.045 [1 kHz] / 0.010 [1 MHz]
dielectric strength	14 kV/mm
class of inflammability	UL 94 V-0
type of delivery	on both sides covered with protective foil/ plates, usable area 300x200mm/ other dimensions upon request
storage conditions	-20 °C - +50 °C/ 45 % - 85 % humidity
shelf life	12 months

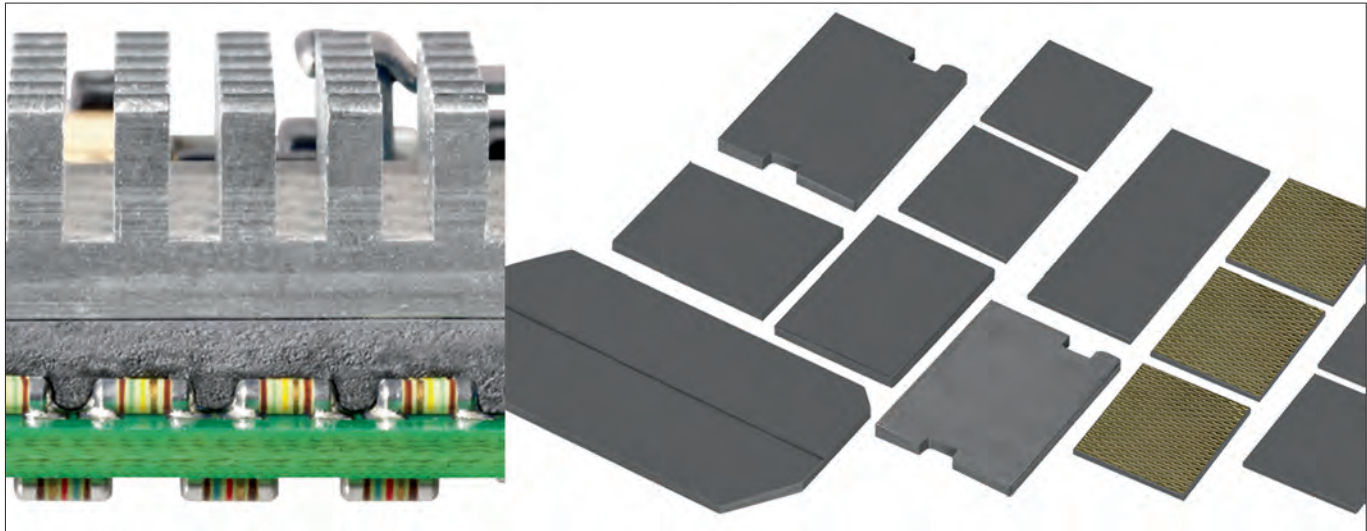

- specially soft design
- levels smallest air gaps and unevennesses
- cuts and contours with cutouts according to customer's specifications

art. no.	material thickness [mm]	R _{th} (100 kPa) [°C in ² /W]	R _{th} (100 kPa) [°C cm ² /W]
GEL 28 S 10	1.0 ±0.15	0.42	2.7
GEL 28 S 15	1.5 ±0.20	0.60	3.9
GEL 28 S 20	2.0 ±0.30	0.76	4.9
GEL 28 S 25	2.5 ±0.30	0.90	5.8
GEL 28 S 30	3.0 ±0.30	1.02	6.6
GEL 28 S 35	3.5 ±0.35	1.15	7.4
GEL 28 S 40	4.0 ±0.40	1.27	8.2
GEL 28 S 45	4.5 ±0.45	1.45	9.4
GEL 28 S 50	5.0 ±0.50	1.64	10.6
GEL 28 S			
version	standard		
colour	grey		
density	2.6 g/cm ³		
hardness	9 ASKER C		
thermal conductivity	2,5 W/m·K		
temperature range	-40°C... +150°C		
volume resistance	1·10 ¹¹ Ω·m		
dielectric constant	7.21 [50 Hz] / 6.73 [1 kHz] / 6.25 [1 MHz]		
dielectric loss factor	0.059 [50 Hz] / 0.031 [1 kHz] / 0.007 [1 MHz]		
dielectric strength	18 kV/mm		
class of inflammability	UL 94 V-0		
type of delivery	on both sides covered with protective foil/ plates, usable area 300x200mm/ other dimensions upon request		
storage conditions	-20 °C - +50 °C/ 45 % - 85 % humidity		
shelf life	12 months		

Gel thermal conductive foils for extreme compression

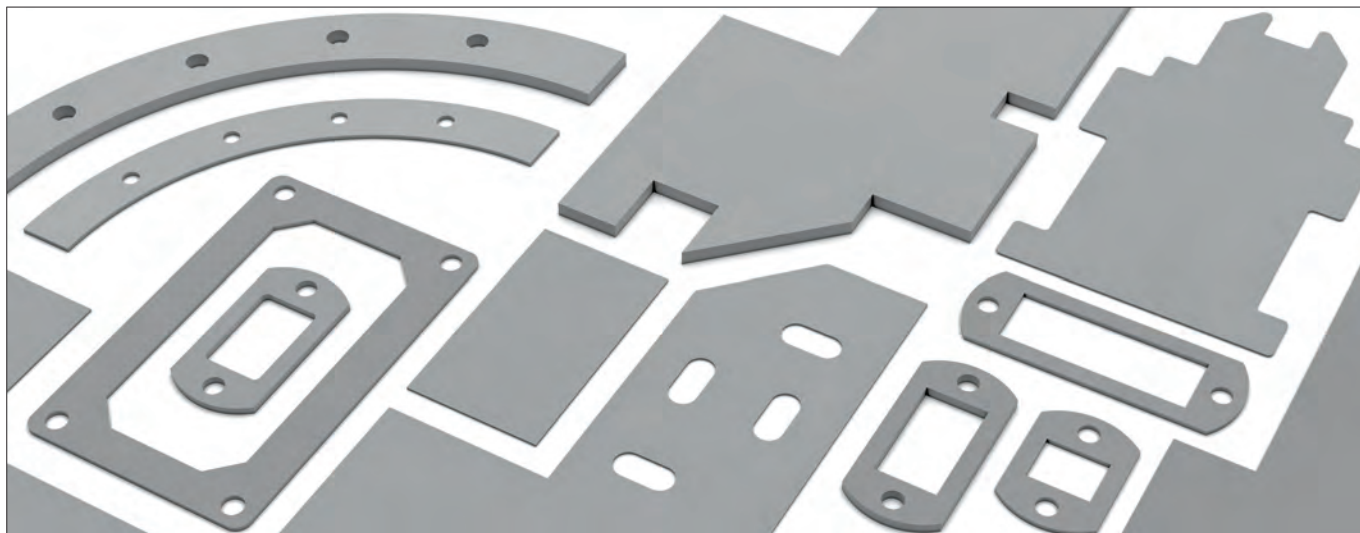

- very soft silicone-based thermal conductive material
- double side adhesive surface
- good chemical and ageing resistance
- other material thicknesses on request
- cuts and contours according to customised drawing specifications

art. no.	material thickness [mm]
GEL 30 S 05	0.5
GEL 30 S 10	1.0
GEL 30 S 15	1.5
GEL 30 S 20	2.0
GEL 30 S 25	2.5
GEL 30 S 30	3.0
GEL 30 S 35	3.5
GEL 30 S 40	4.0

GEL 30 S	
version	silicone foil, protective film on both sides
colour	grey
hardness	7 Shore A
thermal conductivity	3 W/m·K
temperature range	-60°C ... +200°C
elongation	450 %
tear strength	0.7 N/mm ²
dielectric strength	1 kV/mm
class of inflammability	UL 94 V-0
type of delivery	plates, usable area 305x305mm/ other dimensions upon request
shelf life	16 months

Thermal resistances vs. contact pressure					
pressure [psi]	10	20	30	40	50
thermal impedance GEL 30 S 30 [K·cm ² /W]	16,1	16,0	14,2	13,7	13,0

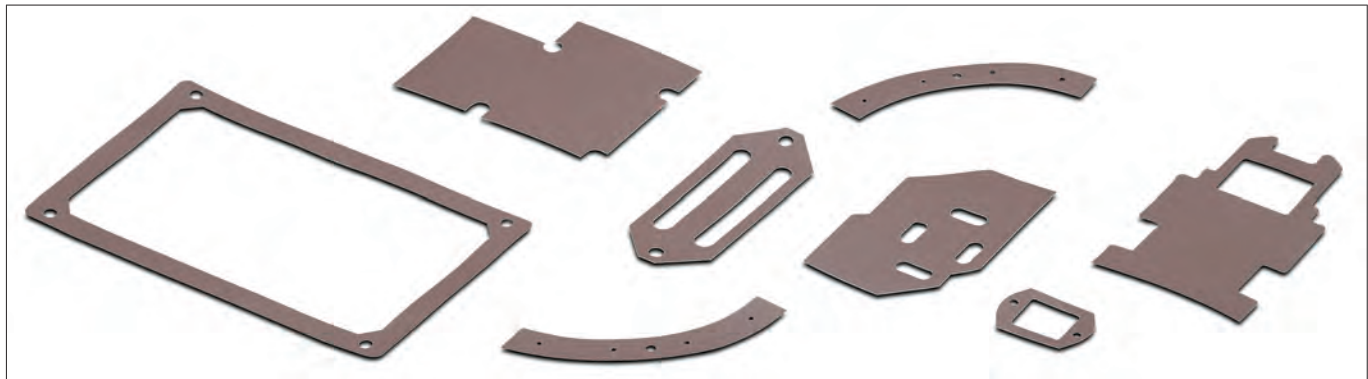

- very soft and compressible thermal conductive foil
- simple compensation of bigger differences in components
- double-sided adhesive surfaces with protective foil
- excellent dielectric strength
- drawing parts acc. to customer's specification upon request

art. no.	material thickness [mm]	R _{th} (100 kPa) [°C in ² /W]	R _{th} (100 kPa) [°C cm ² /W]
GEL 45 S 15	1.5 +0.5/ -0.0	0.45	2.9
GEL 45 S 20	2.0 +0.7/ -0.0	0.52	3.3
GEL 45 S 25	2.5 +0.7/ -0.0	0.67	4.3
GEL 45 S			
version	standard with double-sided adhesive surface		
colour	dark gray		
density	3.2 g/cm ³		
thermal conductivity	4,5 W/m·K		
temperature range	-40°C... +150°C		
volume resistance	1·10 ¹² Ω·m		
dielectric constant	7.37 [50 Hz] / 7.31 [1 kHz] / 7.34 [1 MHz]		
dielectric loss factor	0.0101 [50 Hz] / 0.0022 [1 kHz] / 0.0007 [1 MHz]		
dielectric strength	13 kV/mm		
class of inflammability	UL 94 V-0		
type of delivery	on both sides covered with protective foil/ plates, usable area 300x200mm/ other dimensions upon request		
storage conditions	-20 °C - +50 °C/ 45 % - 85 % humidity		
shelf life	12 months		

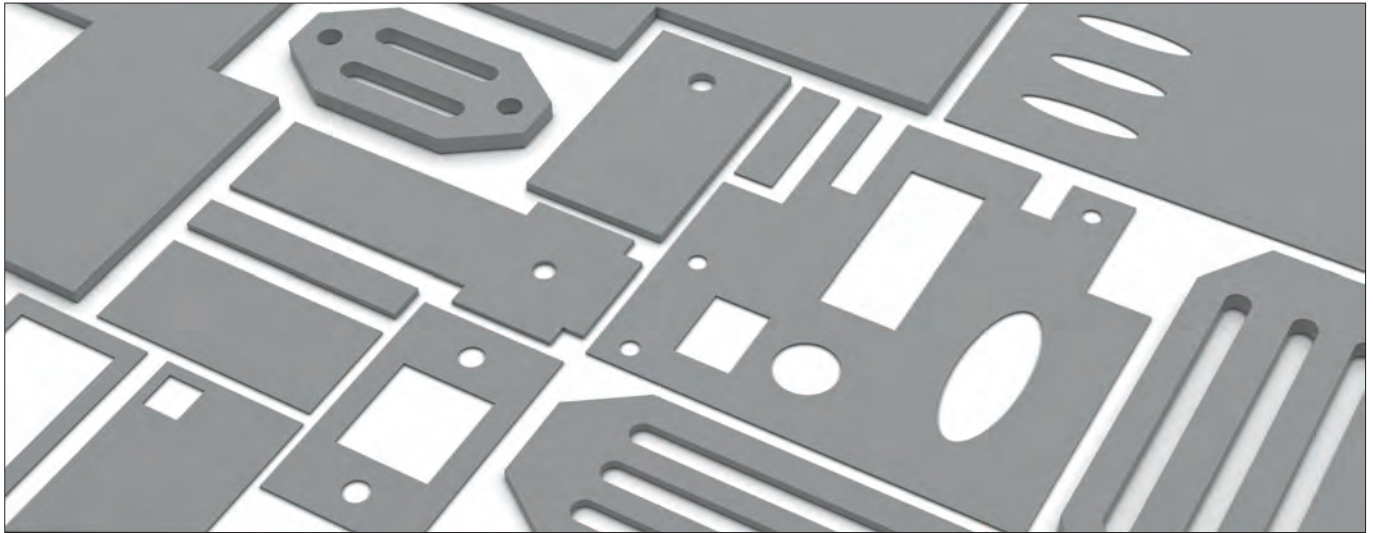

- very soft silicone foil with good compressibility
- mounting facilitation due to adherent surfaces
- very good compensation of larger unevennesses
- low contact pressure to reduce thermal transfer resistances
- shaped parts and material cuts according to your specifications

art. no.	material thickness [mm]
GEL 50 S 05	0.5
GEL 50 S 10	1.0
GEL 50 S 15	1.5
GEL 50 S 20	2.0
GEL 50 S 25	2.5
GEL 50 S 30	3.0
GEL 50 S 35	3.5
GEL 50 S 40	4.0

GEL 50 S	
version	silicone foil, protective film on both sides
colour	grey
hardness	20 Shore A
thermal conductivity	5 W/m·K
temperature range	-60°C ... +200°C
elongation	250 %
tear strength	0.34 N/mm ²
dielectric strength	2 kV/mm
class of inflammability	UL 94 V-0
type of delivery	plates, usable area 305x305mm/ other dimensions upon request
shelf life	16 months

Thermal resistances vs. contact pressure					
pressure [psi]	10	20	30	40	50
thermal impedance GEL 50 S 20 [K·cm ² /W]	8.2	8	7.6	7.3	7



- extremely strong compressible gap-filler thermal conductive foil
- very high efficiency in connection with very high thermal conductivity
- little force for material compression
- perfectly suitable for balancing smallest unevennesses
- cuts and contours according to customer drawing

art. no.	material thickness [mm]	R_{th} (100 kPa) [°C in ² /W]	R_{th} (100 kPa) [°C cm ² /W]
GEL 65 S 05	0,5 ±0.15	0.11	0.71
GEL 65 S 10	1,0 ±0.20	0.15	0.95
GEL 65 S 15	1,5 ±0.20	0.13	0.81
GEL 65 S 20	2,0 ±0.35	0.18	1.14
GEL 65 S			
version	standard with double-sided adhesive surface		
colour	lila		
density	3.2 g/cm ³		
thermal conductivity	6,5 W/m·K		
temperature range	-40°C... +150°C		
volume resistance	2·10 ⁹ Ω·m		
dielectric constant	9.5 [50 Hz] / 8 [1 kHz] / 7.6 [1 MHz]		
dielectric loss factor	0.34 [50 Hz] / 0.055 [1 kHz] / 0.014 [1 MHz]		
dielectric strength	11 kV/mm		
class of inflammability	UL 94 V-0		
type of delivery	on both sides covered with protective foil/ plates, usable area 300x200mm/ other dimensions upon request		
storage conditions	-20 °C - +50 °C/ 45 % - 85 % humidity		
shelf life	12 months		



- very adaptable gel thermal conductive foil
- high thermal conductivity and application temperature range
- very good compression with light contact pressure
- other sheet dimensions and material thicknesses on request
- individual moulded parts according to customer drawing

art. no.	material thickness [mm]
GEL 70 S 05	0.5
GEL 70 S 10	1.0
GEL 70 S 15	1.5
GEL 70 S 20	2.0
GEL 70 S 25	2.5
GEL 70 S 30	3.0
GEL 70 S 35	3.5
GEL 70 S 40	4.0

GEL 70 S	
version	silicone foil, protective film on both sides
colour	dark gray
hardness	10 Shore A
thermal conductivity	7 W/m·K
temperature range	-60°C ... +200°C
elongation	40 %
tear strength	0.34 N/mm ²
dielectric strength	6 kV/mm
class of inflammability	UL 94 V-0
type of delivery	plates, usable area 305x305mm/ other dimensions upon request
shelf life	16 months

Thermal resistances vs. contact pressure					
pressure [psi]	10	20	30	40	50
thermal impedance GEL 70 S 20 [K·cm ² /W]	5.3	5	4.6	4.2	3.9

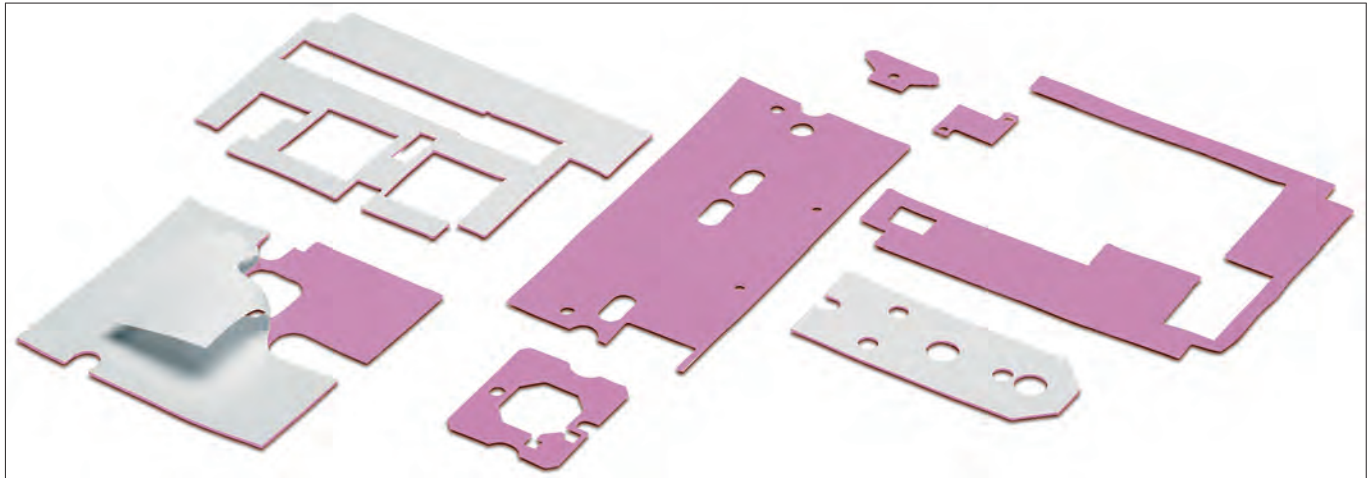

- extremely strong compressible gap-filler thermal conductive foil
- very high efficiency in connection with very high thermal conductivity
- little force for material compression
- perfectly suitable for balancing smallest unevennesses
- cuts and contours according to customer drawing

art. no.	material thickness [mm]	R _{th} (100 kPa) [°C in ² /W]	R _{th} (100 kPa) [°C cm ² /W]
GEL 80 S 05	0.5 ±0.10	0.09	0.55
GEL 80 S 10	1.0 ±0.15	0.14	0.92
GEL 80 S 15	1.5 ±0.25	0.19	1.22
GEL 80 S 20	2.0 ±0.35	0.22	1.43

GEL 80 S	
version	standard with double-sided adhesive surface
colour	red
density	3.3 g/cm ³
thermal conductivity	8 W/m·K
temperature range	-40°C... +150°C
volume resistance	3·10 ¹¹ Ω·m
dielectric constant	12.1 [50 Hz] / 9.6 [1 kHz] / 8.6 [1 MHz]
dielectric loss factor	0.533 [50 Hz] / 0.093 [1 kHz] / 0.015 [1 MHz]
dielectric strength	10 kV/mm
class of inflammability	UL 94 V-0
type of delivery	on both sides covered with protective foil/ plates, usable area 300x200mm/ other dimensions upon request
storage conditions	-20 °C - +50 °C/ 45 % - 85 % humidity
shelf life	12 months



- hoch Wärmeleitende GEL-Wärmeleitfolie
- hohe komprimierbarkeit zum sehr guten Ausgleich von Unebenheiten und Toleranzen
- in verschiedenen Materialstärken zum Ausgleich von unterschiedlichen Spaltgrößen
- Zuschnitte und Konturen nach kundenspezifischen Zeichnungsvorgaben

art. no.	material thickness [mm]	R_{th} (100 kPa) [°C in ² /W]	R_{th} (100 kPa) [°C cm ² /W]
GEL 130 S 03	0,3 ±0.06	0.20	0.03
GEL 130 S 05	0,5 ±0.10	0.29	0.04
GEL 130 S 10	1,0 ±0.15	0.65	0.10
GEL 130 S 15	1,5 ±0.20	0.83	0.13
GEL 130 S 20	2,0 ±0.30	1.07	0.17

GEL 130 S	
version	standard with double-sided adhesive surface
colour	pink
density	3 g/cm ³
thermal conductivity	13 W/m·K
temperature range	-40°C... +150°C
volume resistance	2·10 ⁹ Ω·m
dielectric constant	13.6 [50 Hz] / 10.6 [1 kHz] / 9.3 [1 MHz]
dielectric loss factor	0.5 [50 Hz] / 0.095 [1 kHz] / 0.029 [1 MHz]
dielectric strength	13 kV/mm
class of inflammability	UL 94 V-0
type of delivery	on both sides covered with protective foil/ plates, usable area 300x200mm/ other dimensions upon request
storage conditions	-20 °C - +50 °C/ 45 % - 85 % humidity
shelf life	12 months



- two-part fluid gap filling material
- high dimensional stability after mounting
- automatic dispensation
- optimum balance of roughness and unevenness
- to be stored at 25 °C room temperature, vertical standing with opening pointing downwards
- other delivery forms and container sizes upon request
- more package sizes and container types upon request
- store cool and dry

art. no.	basin	contents of delivery
GEL S 18	cartridge	1x 50 ml cartridge / 3x mixer GEL M 18
GEL S 18		
version	two-part fluid gap filling material/ silicone	
colour	white (A/B)	
density	2.7 g/cm ³	
hardness	50 Shore 00	
thermal conductivity	1,8 W/m·K	
mixture proportion	1:1	
viscosity	25 Pa·s	
temperature range	-60°C ... +200°C	
volume resistance	10 ¹⁰ Ω·m	
dielectric constant	6.4 [1 kHz]	
heat capacity	1 J/g·K	
dielectric strength	400 V	
durability	6 months @ 25°C	
working life at room temperature	60 min @ 25°C	
hardening time	300 min @ 25°C / 10 min @ 100°C	
class of inflammability	UL 94 V-0	
type of delivery	cartridge with additional mixers	
storage conditions	+5 °C - +25 °C / 50 % humidity	
shelf life	6 months	

Accessories

art. no.	contents of delivery
GEL M 18	10x mixer für 50 ml cartridge (packing unit 10 pieces)
WLK P	1x applicator gun for 50 ml cartridge



- two-component liquid gap filler material
- ceramic highly filled silicone elastomers and gels
- high heat dissipation and good insulation properties with low viscosity
- automatic dispensing option
- storage at 25 °C room temperature, vertically upright with the opening facing down
- other delivery forms and container sizes on request
- store in a cool, dry place

art. no.	basin	contents of delivery		
GEL S 20	cartridge	1x 50 ml cartridge / 3x mixer GEL M 50		
GEL S 30				
GEL S 40				
	GEL S 20	GEL S 30	GEL S 40	
version	two-part fluid gap filling material/ silicone			
colour	yellow	green	lila	
density	2.3 g/cm ³	2.94 g/cm ³	3.05 g/cm ³	
hardness	45 - 60 Shore 00	65 - 85 Shore 00		
thermal conductivity	1,8 W/m·K	3 W/m·K	4,3 W/m·K	
mixture proportion	1:1			
viscosity	45-70 Pa·s	50-80 Pa·s	75-110 Pa·s	
temperature range	-40°C... +200°C			
heat capacity	1 J/g·K			
durability	6 months @ 25°C			
dielectric strength	20 kV/mm	12 kV/mm	10 kV/mm	
working life at room temperature	20 min @ 25 °C			
hardening time	60 min @ 25 °C			
class of inflammability	UL 94 V-0			
type of delivery	cartridge with additional mixers			
storage conditions	+5 °C - +40 °C/ 30 % - 70 % humidity			
shelf life	12 months			

Accessories

art. no.	contents of delivery
GEL M 50	10x mixer für 50 ml cartridge (packing unit 10 pieces)
WLK P	1x applicator gun for 50 ml cartridge





- fully curing one-component system
- very good thermal conductivity
- thicker and thinner layer thicknesses possible
- no bleeding, small compression force necessary
- automatic dispensable
- more package sizes and container types upon request
- store cool and dry

art. no.	basin	contents of delivery
GEL S 35 10	syringe	1x 10 ml syringe
GEL S 35	cartridge	1x 30 ml cartridge
GEL S 35		
version	one-part fluid gap filling material/ silicone	
colour	pink	
density	3.2 g/cm ³	
thermal conductivity	3,5 W/m·K	
temperature range	-55°C ... +200°C	
volume resistance	10 ¹² Ω·m	
dielectric constant	7 [100 kHz]	
heat capacity	1 J/g·K	
dielectric strength	8 kV/mm	
durability	18 months	
class of inflammability	UL 94 V-0	
type of delivery	syringe/ cartridge	
storage conditions	+15 °C - +30 °C	
shelf life	12 months	

Kapton insulator washers

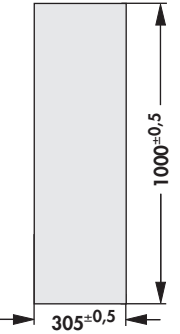
- very low thermal resistance
- optimised heat conductivity
- best mechanical characteristics
- polyimide-carrier foil with silicone-free phase changing thermal conductive layer completely coated on both sides
- clean processing, no abrasion of the coating
- stacked foils do not stick together
- good resistance against cleaning agents
- no cold flow
- low pressure force necessary, thus particularly applicable for spring-fixing of semiconductors
- cuttings and special versions according to customer's requirements
- the thermal details refer to an area of 1 inch² (6.45 cm²)

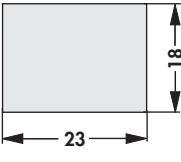
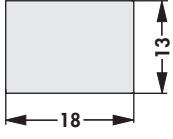
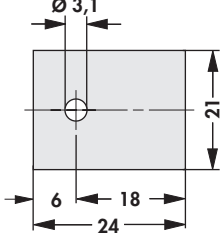
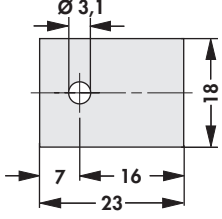
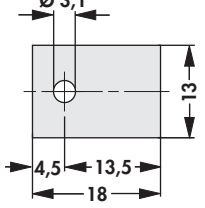
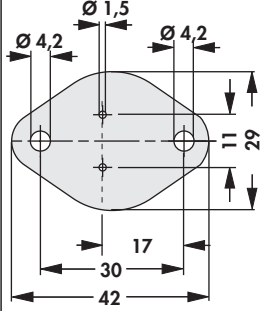
				
art. no. KAP 1 P suitable for pre-cut parts (plate)	art. no. KAP 247 O TO 248/ TO 218/ TO 247	art. no. KAP 218 O TO 218	art. no. KAP 220 O TO 220	art. no. KAP 218 TO 248/ TO 218/ TO 247
				
art. no. KAP 220 G TO 220	art. no. KAP 220 K TO 220	art. no. KAP 3 K TO 3		
	KAP 1 P		KAP	
material	polyimide-carrier foil with silicone-free phase changing thermal conductive layer completely coated on both sides			
phase change temperature	52 °C			
thermal resistance	0.15 K/W [at 1 inch ² ; = 6.45 cm ² ; = TO 3 (KAP 3)]			
temperature range	-40°C... +150°C			
thermal conductivity	0.45 W/m·K (substrate)			
insulation resistance	10 ¹⁴ Ω			
elongation	30 %			
material thickness	0.077mm (substrate 0.05mm)			
dielectric strength	7.8 kV			
class of inflammability	UL 94 V-0			
type of delivery	plate		cut	

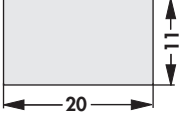
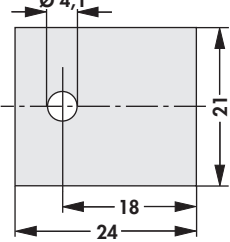
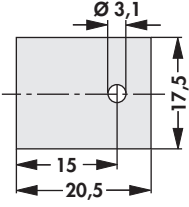
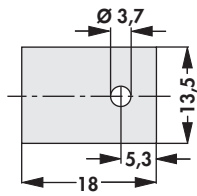
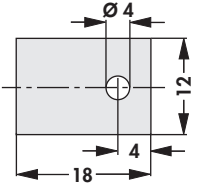
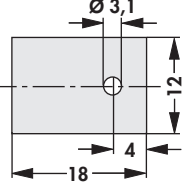
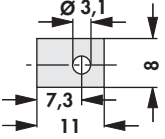
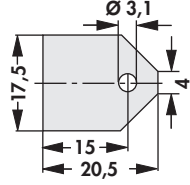
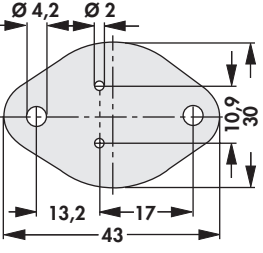
				
art. no. GS 220 C TO 220	art. no. GS 218 TO 218	art. no. GS 3 P SL TOP 3	art. no. GS 66 P TO 66	art. no. GS 220 4 TO 220
				
art. no. GS 220 P TO 220	art. no. GS 32 P SOT 32	art. no. GS 3 P TOP 3	art. no. GS 3 TO 3	
GS				
material	muskovit			
material thickness	0.05 mm			
thermal resistance (GS 3)	0.4 K/W			
dielectric strength	5 kV			
insulation resistance	3·10 ¹⁷ Ω·cm			

A

Aluminium oxide wafers

– other thicknesses and versions on request

 \pm = thickness; \square = flatness

art. no. AOS 247 ± 1 mm \square 0,02 mm	art. no. AOS 218 247 ± 3 mm \square 0,02 mm	art. no. AOS 218 247 1 $\pm 1,5$ mm \square 0,02 mm	art. no. AOS 3 P 2 ± 1 mm \square 0,02 mm	art. no. AOS 3 P SL $\pm 1,5$ mm \square 0,02 mm
art. no. AOS 220 3 $\pm 1,6$ mm \square 0,02 mm	art. no. AOS 220 SL $\pm 4,5$ mm \square 0,02 mm	art. no. AOS 220 4 $\pm 1,5$ mm \square 0,02 mm	art. no. AOS 220 $\pm 1,5$ mm \square 0,02 mm	art. no. AOS 32 $\pm 1,5$ mm \square 0,02 mm
art. no. AOS 127 ± 3 mm \square 0,02 mm	art. no. AOS 3 P $\pm 1,5$ mm \square 0,02 mm	art. no. AOS 5 $\pm 1,5$ mm \square 0,02 mm	art. no. AOS 93 $\pm 2,3$ mm \square 0,02 mm	art. no. AOS 18 $\pm 1,5$ mm \square 0,02 mm
art. no. AOS 3 ± 3 mm \square 0,02 mm	art. no. AOS 66 $\pm 2,5$ mm \square 0,02 mm			
AOS				
material	AL ₂ O ₃ - ceramics			
specific electrical resistance	> 10 ¹⁴ Ω/cm			
thermal conductivity	25 W/m·K			
dielectric constant	9			
linear expansion coefficient	~8·10 ⁻⁶ /K			
thermal resistance	0,3 K/W [at 1 inch ² ; = 6,45 cm ² ; = TO 3 (AOS 3 G)]			
dielectric strength	10 kV/mm			

M

N

Aluminium oxide wafers according to customer's instructions

- laser-cut versions with outer dimensions and cutouts according to customer's requirements
- other plate dimensions upon request

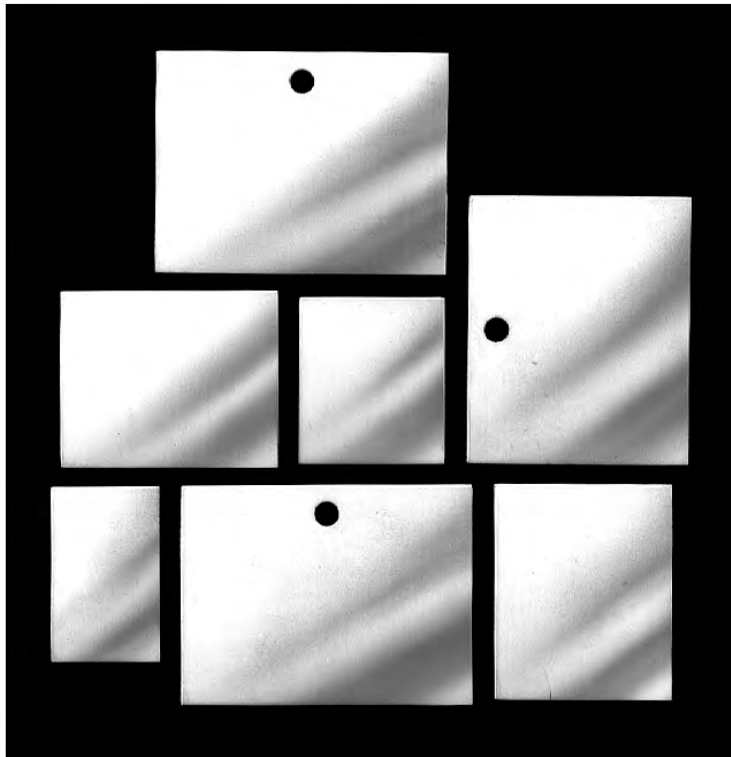

material thickness [mm]	outer dimensions [mm]
0.250	106,6x106,6
0.300	
0.400	114.3x114.3
0.500	106,6x106,6/ 160x113
0.635	106,6x106,6/ 160x113/ 180x113
0.800	114.3x114.3/ 160x113/ 165x114
1.000	114.3x114.3/ 160x113/ 165x114/ 180x130
1.270	114.3x114.3
1.500	114.3x114.3/ 290x100
2.000	114.3x114.3
2.540	

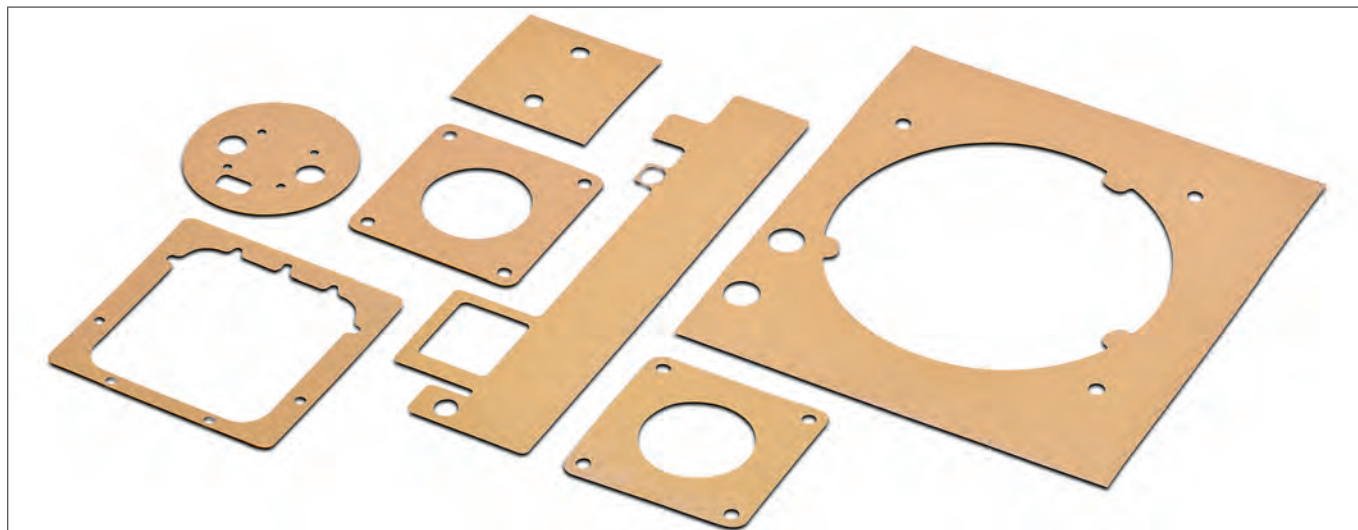

- phase change material on a polyimide basis
- very good thermal properties
- one-sided adhesive layer eases the mounting
- particularly suitable for the application of spring clips
- cuts and contours upon customised drawing specifications

art. no.	material thickness [mm]
FSF 15 P 011	0.114
FSF 15 P 012	0.127
FSF 15 P 014	0.140

FSF 15 P	
version	electrically insulating phase change material with polyimide reinforcement and one-sided adhesive layer
colour	gold
phase change temperature	52 °C
thermal conductivity	1,5 W/m·K
temperature range	-40°C... +150°C
elongation	40 %
volume resistance	10 ¹² Ω·m
dielectric constant	4.5 [1 kHz]
tear strength	7,000 psi
dielectric strength	5 kV
class of inflammability	UL 94 V-0
type of delivery	rolled goods, roll width 266mm/ cuttings on customer's requirement
storage conditions	-20 °C - +50 °C/ 50 % humidity
shelf life	12 months

Thermal resistances vs. contact pressure / surface TO 220					
pressure [psi]	10	25	50	100	200
thermal resistance FSF 15 P 011 [K/W]	1.20	1.15	1.11	1.06	1.00
thermal resistance FSF 15 P 012 [K/W]	1.47	1.41	1.37	1.33	1.29
thermal resistance FSF 15 P 014 [K/W]	1.59	1.48	1.43	1.38	1.35
thermal impedance FSF 15 P 011 [K-cm ² /W]	1.31	1.25	1.19	1.13	1.06
thermal impedance FSF 15 P 012 [K-cm ² /W]	1.44	1.38	1.31	1.25	1.19
thermal impedance FSF 15 P 014 [K-cm ² /W]	1.75	1.69	1.63	1.56	1.50



- phase change material on a polyimide basis
- very good thermal properties
- easy handling and high dielectric strength
- particularly suitable for the application of spring clips
- cuts and contours upon customised drawing specifications

art. no.	material thickness [mm]
FSF 16 P 010	0.102
FSF 16 P 011	0.114
FSF 16 P 012	0.127
FSF 16 P	
version	electrically insulating phase change material with polyimide reinforcement
colour	green
phase change temperature	55 °C
thermal conductivity	1,6 W/m·K
temperature range	-40°C... +150°C
elongation	40 %
volume resistance	10 ¹² Ω·m
dielectric constant	4.5 [1 kHz]
tear strength	7,000 psi
dielectric strength	5 kV
class of inflammability	UL 94 V-0
type of delivery	plates, usable area 300x275mm/ other dimensions upon request
storage conditions	-20 °C - +50 °C/ 50 % humidity
shelf life	12 months

Thermal resistances vs. contact pressure					
pressure [psi]	10	25	50	100	200
thermal resistance FSF 16 P 010 [K/W]	0.95	0.94	0.92	0.91	0.90
thermal resistance FSF 16 P 011 [K/W]	1.19	1.17	1.16	1.14	1.12
thermal resistance FSF 16 P 012 [K/W]	1.38	1.37	1.35	1.33	1.32
thermal impedance FSF 16 P 010 [K-cm ² /W]	0.81	0.81	0.75	0.75	0.75
thermal impedance FSF 16 P 011 [K-cm ² /W]	1.06	1.00	1.00	1.00	0.93
thermal impedance FSF 16 P 012 [K-cm ² /W]	1.18	1.18	1.18	1.12	1.12

Phase Change thermal interface material

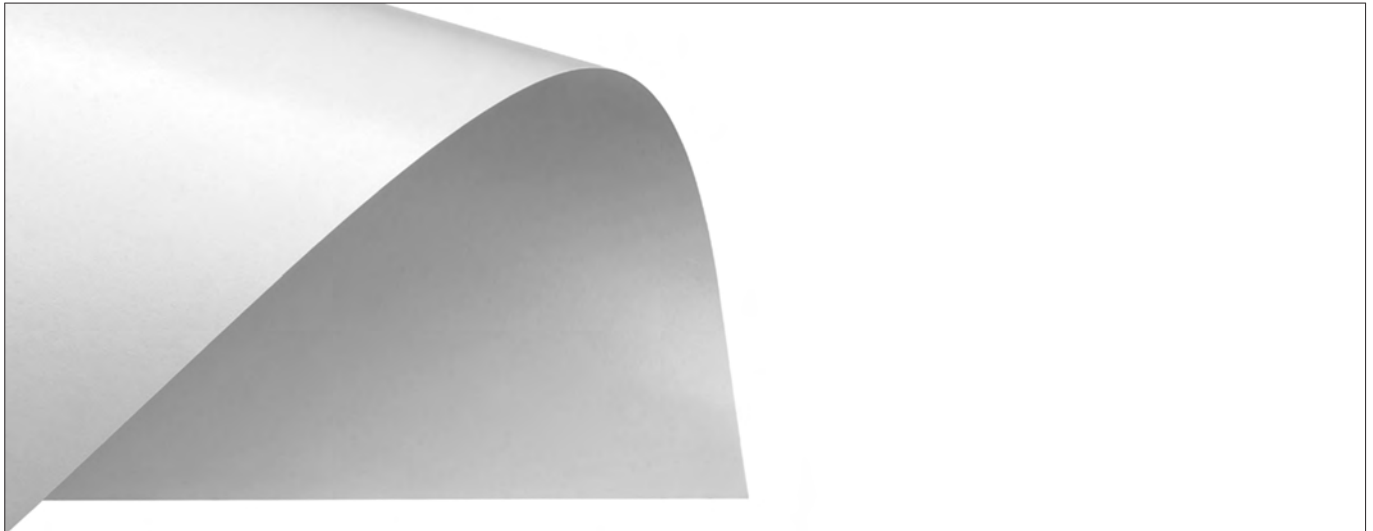

- strapless (free standing film) changing condition thermal conductive material as a foil
- material with phase changing temperature at 48 °C or 52 °C
- best thermal conductivity, above the phase change temperature the material flows in all gaps of the impinged device and heatsink
- thixotropic, therefore no migration of the material away from the moistened surface
- no influence on the thermal conductivity due to thermal cycles
- only low contact pressure necessary, as it is no elastomer and therefore ideally suitable for clamp mounting of the devices
- not electrically conductive, but no insulator
- self-adhesive properties, also suitable for large surfaces
- no toxic ingredients
- customised cuts upon request
- with double-sided protective film

art. no.	material thickness [mm]	
FSF 30 P	0.12 ±0.025	
FSF 20 P	0.20 ±0.025	
	FSF 30 P	FSF 20 P
colour	grey	white
density	2.4 g/cm ³	2.9 g/cm ³
phase change temperature	50 °C	48 °C
thermal conductivity	3 W/m·K	2 W/m·K
thermal resistance (1 in², TO 3) at contact pressure of	0.1 K/W 0.031 N/mm ²	0.08 K/W 0.031 N/mm ²
temperature range	≤ +150°C	
adhesive holding force	0.6 N/mm ²	
dielectric constant	5.2 [1 kHz] / 4.8 [1 MHz]	4.8 [1 kHz] / 4.4 [1 MHz]
class of inflammability	UL 94 V-0	
type of delivery	plates, usable area 400x300mm/ other dimensions upon request	
storage conditions	+1 °C - +30 °C/ cool and dark	
shelf life	6 months	

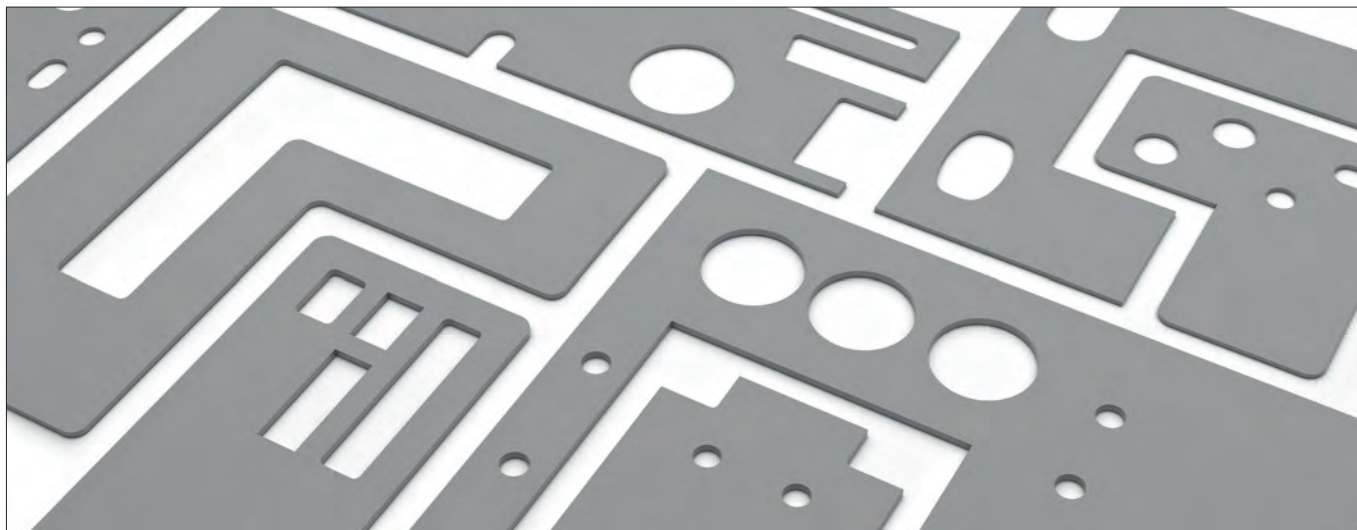

- silicone-free phase change material, therefore no outgassing
- high long-term reliability
- easy handling due to natural adhesion
- more material thicknesses on request
- cuts and contours according to customer-specific drawing specifications

art. no.	material thickness [mm]
FSF 50 P 012	0.125
FSF 50 P 020	0.200
FSF 50 P 025	0.250
FSF 50 P	
version	silicone-free thermoplastic with natural adhesive coating
colour	grey
density	2.6 g/cm ³
phase change temperature	50 °C bis 70 °C
thermal conductivity	5,3 W/m·K
temperature range	-40°C... +125°C
volume resistance	1.4·10 ¹² Ω·m
dielectric constant	31.2 [1 MHz]
class of inflammability	UL 94 V-0
type of delivery	plates, usable area 450x450mm/ other dimensions upon request
storage conditions	0 °C - +40 °C
shelf life	12 months



Silicon thermal transfer compound

– thermal conductive paste used to reduce the thermal transmission resistance between semiconductor and heatsink

art. no.	basin	delivery quantity [g]
WLP 004		4
WLP 035	box	35
WLP 500		500
WLP 300 S		300
WLP 500 S	cartridge (310 ml)	500
WLP		
composition	silicone oil, inorganic filling material	
specific electrical resistance	$>10^{12} \Omega/\text{cm}$	
flashpoint	none (DIN 53213)	
drop point	$>260^\circ\text{C}$	
thermal resistance	no bleeding at (4 h/200°C)	
acid number	$< 0.01 \text{ mg KOH/g}$	
consistance	pastey	
colour	white	
density	1.1 g/cm^3	
thermal conductivity	$0,61 \text{ W/m}\cdot\text{K}$	
temperature range	$-40^\circ\text{C} \dots +250^\circ\text{C}$	
solubility in water	insoluble	



Silicone-free thermal transfer compound

art. no.	basin	delivery quantity [ml]	delivery quantity [g]
WLPF 07 05	syringe	2	—
WLPF 07 10		5	
WLPF 07 20		10	
WLPF 07 50		20	
WLPF 07 300 S	cartridge (310 ml)	—	300
WLPF 07			
composition	silicone free synthetic liquid, metal oxide filling		
consistance	pastey		
colour	white-grey		
density	1.9 g/cm ³		
thermal conductivity	0,7 W/m·K		
temperature range	-40°C... +150°C		
oil separation (thickener)	≤ 2% (40°C / 168h)		
flow pressure at 20°C (thickener)	≤ 300 mbar		
kinetic viscosity (base oil)	ca. 100 mm ² /s (40°C) ca. 14 mm ² /s (100°C)		
shelf life	36 months		

Thermal conductive paste

art. no.	basin	delivery quantity [ml]	delivery quantity [g]
WLPF 13 05	syringe	2	—
WLPF 13 10		5	
WLPF 13 20		10	
WLPF 13 50		20	
WLPF 13 300 S	cartridge (310 ml)	—	300

WLPF 13	
composition	silicone free synthetic liquid, metal oxide filling
consistance	pastey
colour	greenish
density	2.7 g/cm ³
thermal conductivity	1,3 W/m·K
temperature range	-40°C... +150°C
flow pressure at 20°C (thickener)	≤ 200 mbar
kinetic viscosity (base oil)	ca. 3400 mm ² /s (40°C) ca. 286 mm ² /s (100°C)
shelf life	36 months

art. no.	basin	delivery quantity [ml]	delivery quantity [g]
WLPF 23 05	syringe	2	—
WLPF 23 10		5	
WLPF 23 20		10	
WLPF 23 50		20	
WLPF 23 300 S	cartridge (310 ml)	—	300

WLPF 23	
composition	silicone free synthetic liquid, metal oxide filling
consistance	pastey
colour	green-greyish
density	2.9 g/cm ³
thermal conductivity	2,3 W/m·K
temperature range	-40°C... +150°C
flow pressure at 20°C (thickener)	≤ 400 mbar
kinetic viscosity (base oil)	ca. 3400 mm ² /s (40°C) ca. 286 mm ² /s (100°C)
shelf life	36 months

art. no.	basin	delivery quantity [ml]	delivery quantity [g]
WLPF 33 05	syringe	2	—
WLPF 33 10		5	
WLPF 33 20		10	
WLPF 33 50		20	
WLPF 33 300 S	cartridge (310 ml)	—	300
WLPF 33			
composition	silicone free synthetic liquid, metal oxide filling		
consistance	pasty		
colour	white		
density	2.9 g/cm ³		
thermal conductivity	3,3 W/m·K		
temperature range	-40°C ... +160°C		
flow pressure at 20°C (thickener)	≤ 200 mbar		
kinetic viscosity (base oil)	ca. 3400 mm ² /s (40°C) ca. 286 mm ² /s (100°C)		
shelf life	36 months		

Ceramic filled, silicone-free thermal conductive paste with high thermal conductivity

- suitable especially for silicone-sensitive applications
- no drying out, hardening or melting of the thermal conductive paste
- high long-term stability
- further package sizes, container types such as cans, cartridge, etc. upon request



art. no.	basin	delivery quantity [ml]
WLPK 5	syringe	5
WLPK 10		10
WLPK		
composition	silicone-free, synthetic fluid ceramic filled	
consistance	pasty	
colour	silver	
density	1.4 g/cm ³	
thermal conductivity	10 W/m·K	
temperature range	-60°C ... +150°C	
dielectric strength	not applicable, because conducting	
solubility in water	insoluble	
storage conditions	+5 °C - +35 °C/ 30 % - 70 % humidity	
shelf life	12 months	

Thermally conductive adhesive

- thermally conductive, electrically non-conductive adhesive
- two part epoxy resin adhesive, metaloxide filled
- fully replaces mechanical fastenings
- excellent function and application characteristics
- **to be stored at a cool and dark place**

WLK 5

WLK 10

art. no.	composition	art. no.	composition
WLK 5	5 g resin/0.5 g hardener	WLK 10	10 g resin/1 g hardener

WLK 30

WLK 120

art. no.	composition	art. no.	composition
WLK 30	30 g resin/3 g hardener	WLK 120	120 g resin/12 g hardener

WLK	
thermal conductivity	0,836 W/m·K
specific thermal resistance	1.2 m·K/W
temperature range	-56°C... +149°C
hardening time	20°C approx. 16-24h / 25°C approx. 8 h / 120°C approx. 20 min
volume resistance	10 ¹⁶ Ω/cm
glue layer	Epoxid
mixture proportion	10:1
shelf life	24 months

Thermally conductive adhesive

- solvent-free and thermal conductive two part adhesive
- epoxy based filled with aluminium oxide
- composition of hardener and resin (1:1) with statical mixing tube
- lockability of the container via Luer-Lock System
- good usage and working properties
- more package sizes and container types upon request
- store cool and dry



art. no.	basin	contents of delivery
WLK DK 4	syringe	1x 4 ml syringe / 3x mixer WLK M4
WLK DK 10		1x 10 ml syringe / 3x mixer WLK M4
WLK DK 50	cartridge	1x 50 ml cartridge / 3x mixer WLK M 50
WLK DK		
thermal conductivity	1 W/m·K	
specific thermal resistance	118°C cm/W	
temperature range	-50°C... +145°C	
working life at room temperature	approx. 30 min	
hardening time	60°C approx. 4 h/25°C approx. 16 h	
volume resistance	8·10 ¹¹ Ω/cm	
glue layer	Epoxid	
mixture proportion	1:1	
storage conditions	+25 °C/ 50 % humidity	
shelf life	12 months	

Accessories

art. no.	contents of delivery
WLK M 4	10x mixer für 4 & 10 ml syringe (packing unit 10 pieces)
WLK M 50	10x mixer für 50 ml cartridge (packing unit 10 pieces)
WLK P	1x applicator gun for 50 ml cartridge

Thermally conductive adhesive

- space networking thermal conductive glue made on silicone basis
- very good thermal conductivity
- mixing in ration 1:1 with static mixing tube
- hardening will be proceeded at room temperature
- wide range of temperatures
- store cool, dark and dry



art. no.	basin	contents of delivery
WLK SK 50	cartridge	1x 50 ml cartridge / 3x mixer WLK SK M
WLK SK 50		
version	2-component silicone thermal adhesive	
colour	violet	
density	2.8 g/cm ³	
hardness	65 Shore A	
thermal conductivity	2 W/m·K	
temperature range	-60°C... +180°C	
working life at room temperature	approx. 30 min	
hardening time	25°C approx. 8 h / 50°C approx. 4 h / 85°C approx. 1 h	
volume resistance	10 ¹¹ Ω·m	
dielectric constant	6.9 [1 KHz]	
heat capacity	1 J/g·K	
dielectric strength	10.8 kV/mm	
Scherfestigkeit bei RT	1.4 MPa	
class of inflammability	UL 94 V-0	
storage conditions	+5 °C - +25 °C/ 50 % humidity	
shelf life	6 months	

Accessories

art. no.	contents of delivery
WLK SK M	10x mixer für 50 ml cartridge (packing unit 10 pieces)
WLK P	1x applicator gun for 50 ml cartridge



Mounting rail fastening

- universal clip fasteners made of aluminium or plastic
- suitable for rail material thicknesses from 1 to 2.3 mm in accordance with DIN EN 60 715
- quick and easy installation with secure hold
- designs with integrated hole pattern
- several moulded wire springs to increase the load-bearing capacity
- special designs on request

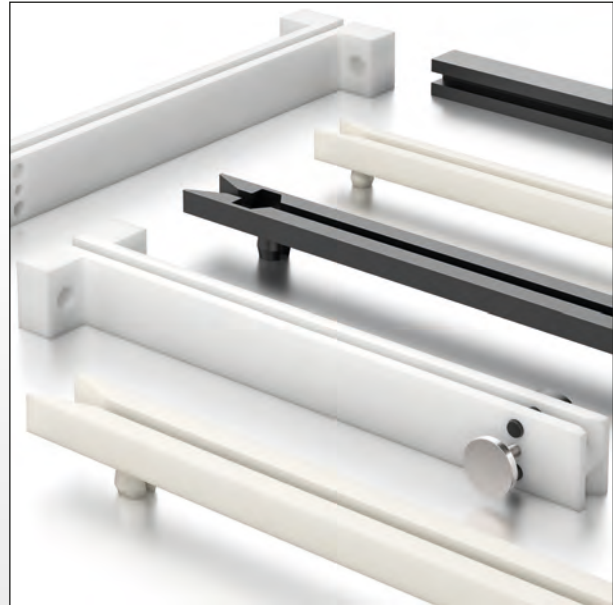

Guide rails for printed circuit boards

- for horizontal and vertical installation
- suitable for board thicknesses from 0.5 – 1.85 mm
- with and without locking mechanism
- narrow and wide designs
- screw and snap-in versions, extraction handles with dowel pin fixing
- special designs on request



Distance bolts and distance sleeves

- insulating and distance bolts with internal and external threads
- insulating mounting of heatsinks, circuit boards, case parts, etc.
- mechanically very stable designs
- temperature-resistant distance rolls in accordance with UL 94 V-0
- other lengths, thread types and designs on request

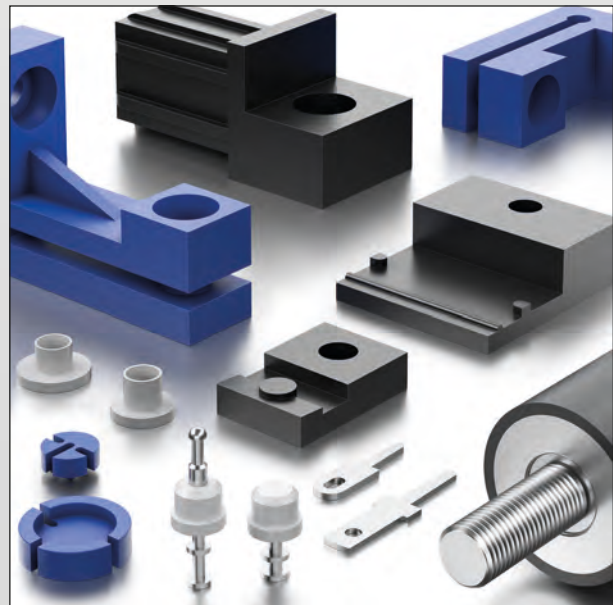

Mounting material for mechanical components

- glass fibre reinforced mounting parts for heatsinks
- various types of insulating bushes made from different plastics
- Insulating clamping pieces for power transistors for electrically insulating device mounting
- soldering support points with attached insulating body
- solder pins for direct mounting on printed circuit boards
- vibration buffers for vibration damping and -isolation



- universal, solid plastic clip fastening for all 35 mm mounting rails
- suitable for rail material thicknesses from 1 to 2.3 mm according to DIN EN 60 715 (formerly DIN EN 50 022)
- registered design DE 200 07 435.0
- fast and easy mounting of heatsinks, casings etc. due to direct snap up on the mounting rail
- safe hold due to a stable extruded plastic profile with integrated spring back
- electroconductive material or surface on request
- special lengths and treatments on customer's request
- * = examples of mounting rail versions suitable for **KL 35 K**

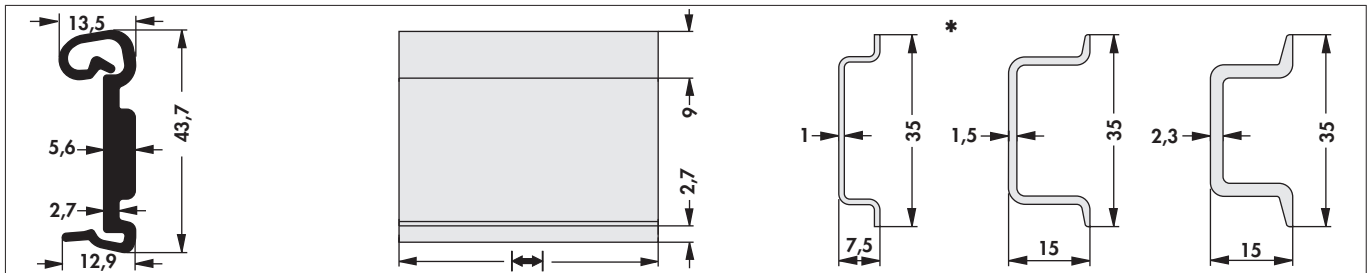

art. no.	dim. [mm]
KL 35 K 40	40
KL 35 K 50	50
KL 35 K 75	75
KL 35 K 100	100

material:	rigid PVC
heat distortion:	-30°C ... +80°C
colour:	anthracite grey
class of inflammability:	accordant UL 94 V-0



- universal, massive aluminium clamp mounting for all 35mm mounting rails
- suitable for rail material thicknesses from 1 to 2.3 mm according to DIN EN 60 715 (formerly DIN EN 50 022)
- fast and easy mounting of heatsinks, casings etc. by direct snap up on the mounting rail
- safe hold due to a stable extruded profile with integrated wire form spring made of stainless steel
- special lengths ($\geq 40\text{mm}$), machinings and surfaces upon request
- * = examples of mounting rail versions suitable for KL 35

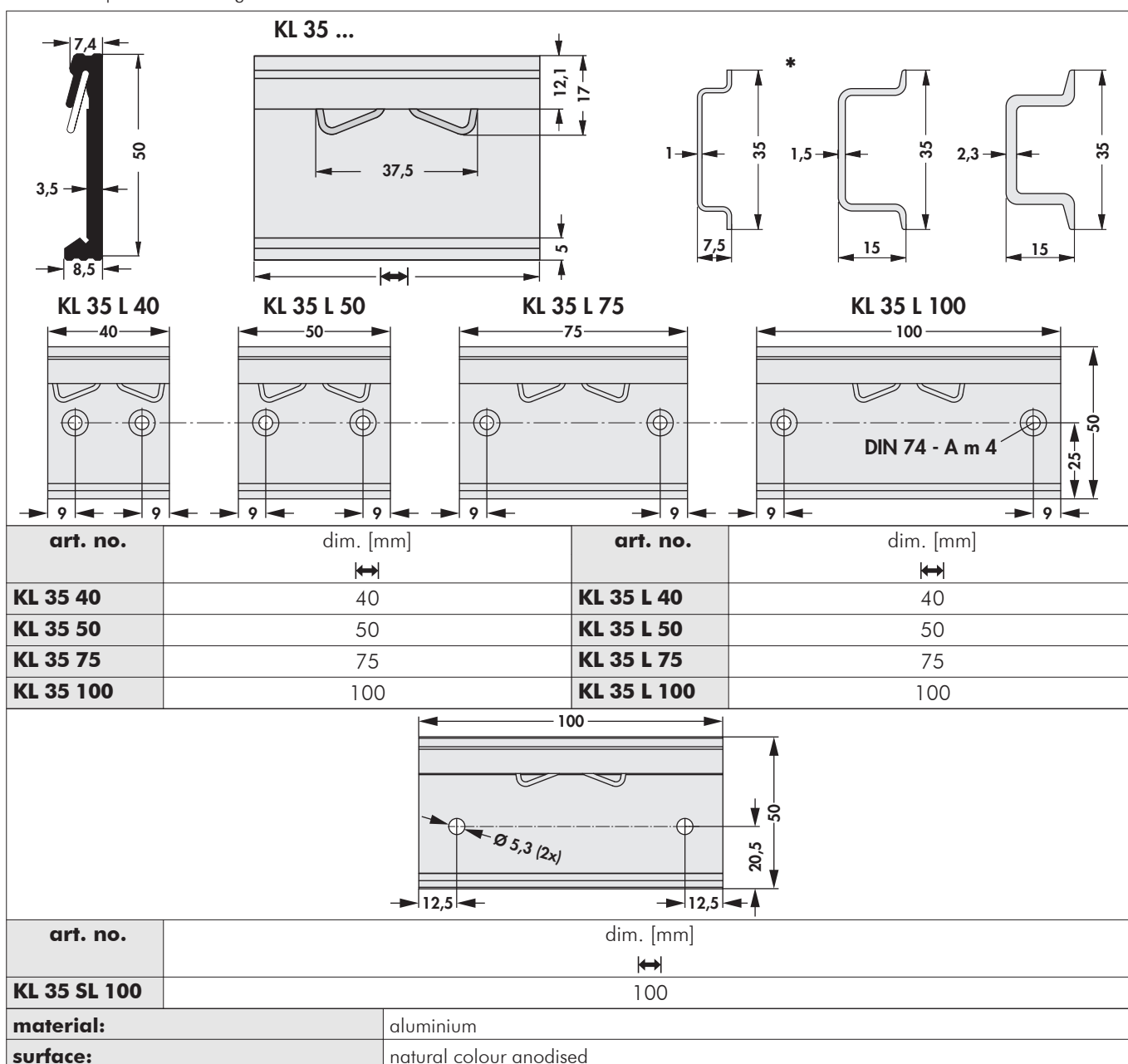



- universal, massive aluminium clamp mounting for all 35mm mounting rails
- suitable for rail material thicknesses from 1 to 2.3 mm according to DIN EN 60 715 (formerly DIN EN 50 022)
- fast and easy mounting of heatsinks, casings etc. by direct snap up on the mounting rail
- safe hold due to a stable extruded profile with integrated wire form spring made of stainless steel
- special lengths (≥ 40 mm), machinings and surfaces upon request
- * = examples of mounting rail versions suitable for KL 35

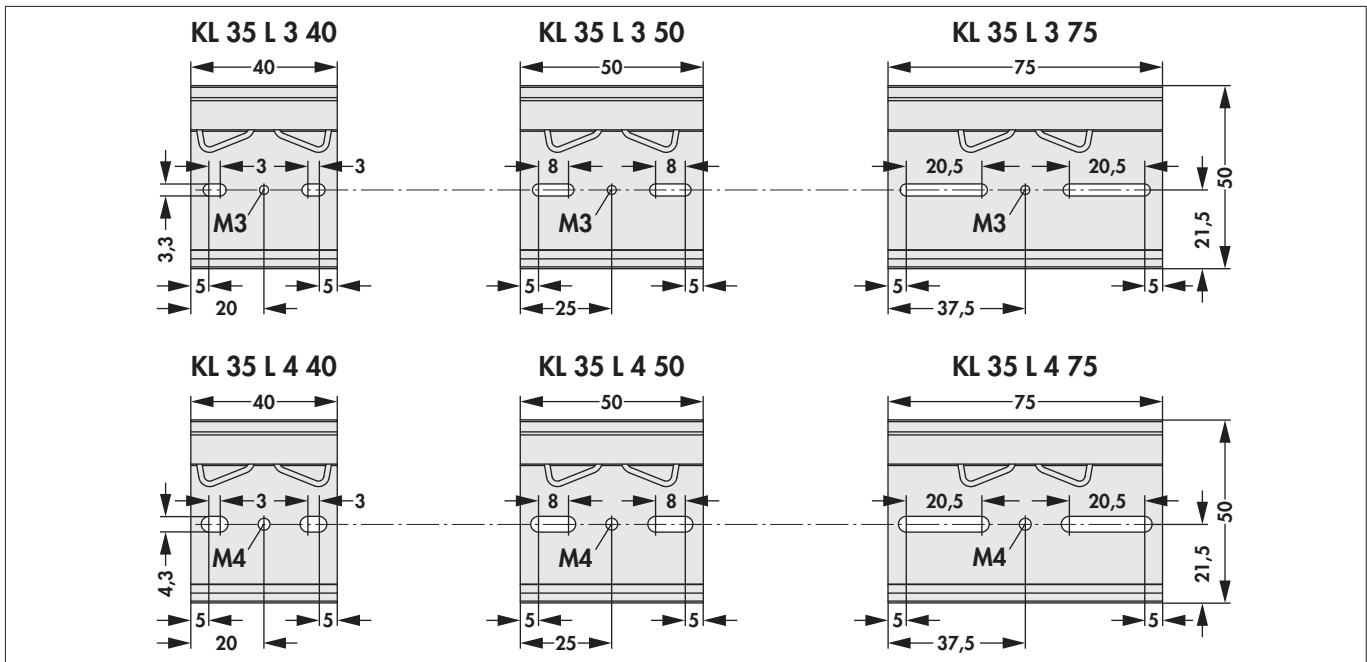

art. no.	dim. [mm]	art. no.	dim. [mm]
KL 35 L 3 40	40	KL 35 L 4 40	40
KL 35 L 3 50	50	KL 35 L 4 50	50
KL 35 L 3 75	75	KL 35 L 4 75	75

material:	aluminium
surface:	natural colour anodised

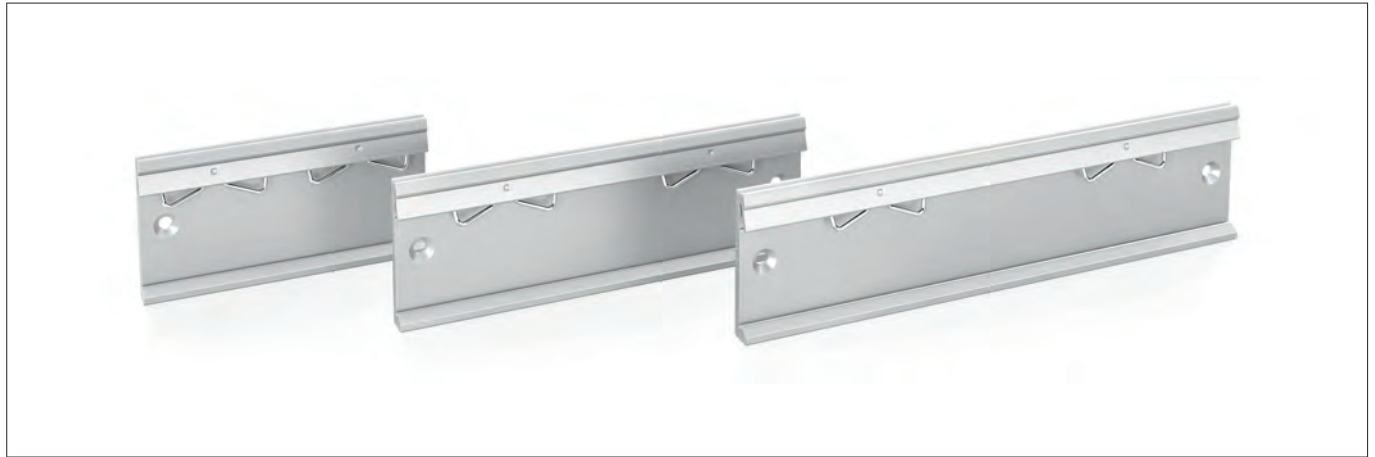

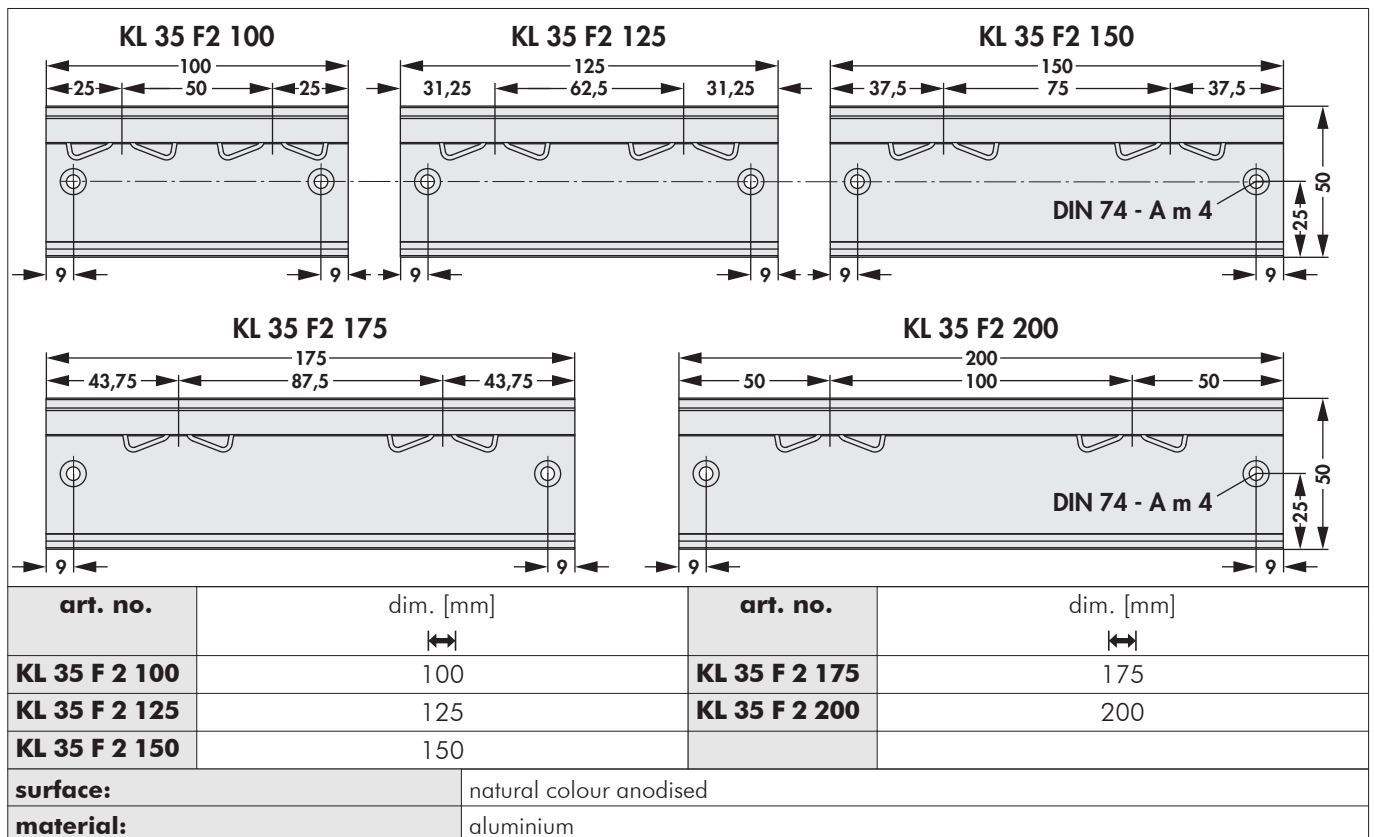

- universal, massive aluminium clamp mounting for all 35mm mounting rails
- suitable for rail material thicknesses from 1 to 2.3 mm according to DIN EN 60 715 (formerly DIN EN 50 022)
- fast and easy mounting of heatsinks, casings etc. by direct snap up on the mounting rail
- safe hold due to a stable extruded profile with integrated wire form spring made of stainless steel
- special lengths ($\geq 40\text{mm}$), machinings and surfaces upon request
- * = examples of mounting rail versions suitable for KL 35 → E 89

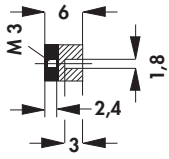
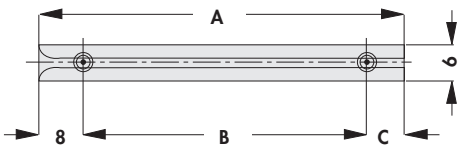

Screw-on type

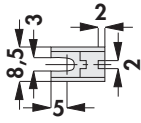
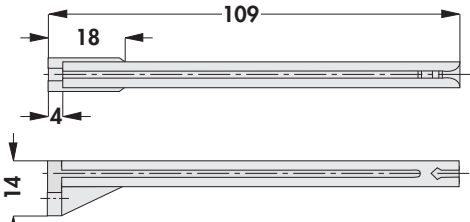
			
art. no.	dim. [mm]		
FS 6 065	A	B	C
FS 6 070	65	50	7
FS 6 080	70	67	12
FS 6 090	80		5
FS 6 100	90	84	15
FS 6 110	100		8
FS 6 120	110		18
FS 6 130	120		28
FS 6 130	130		38
material:	polycarbonate, GF reinforced		
temperature range:	-20°C... +130°C		
thread nut:	brass nickel-plated		
class of inflammability:	UL 94 V-0		

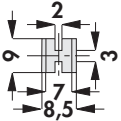
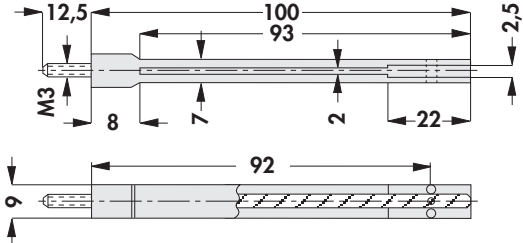
art. no.			
FS 109			
art. no.			
FS 100			
material:	polyamide, GF reinforced		
temperature range:	permanent up to 100°C		
class of inflammability:	UL 94 V-0		

Lockable mounting rails

- lockable by pushing the plastic pin or the metal button
- no conductive connection to the PCB
- the PCB requires a snap-in slot in accordance to the drawing
- other position with locking device on request
- * = position of snap-in slot

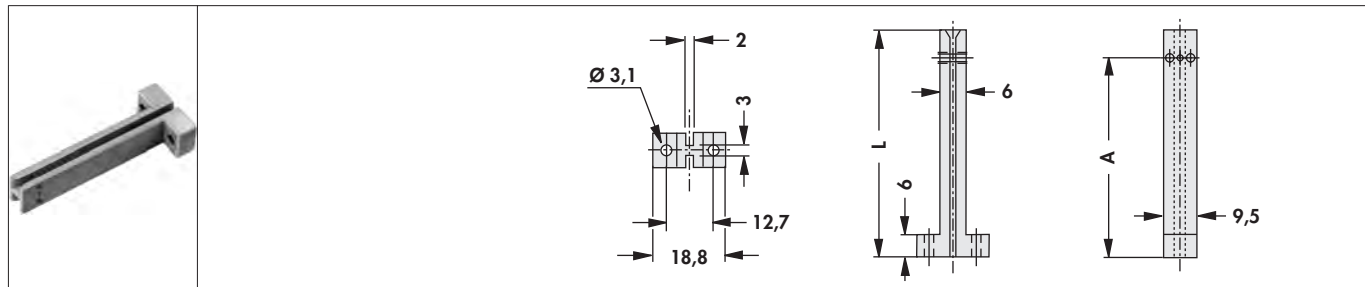

art. no.	version	dim. [mm]		art. no.	version	dim. [mm]	
		L	A			L	A
FS 85 50	without bolting device	50	42	FS 85 70	without bolting device	70	62
FS 85 60		60	52	FS 85		85	76

material:	polyamide, GF reinforced
temperature range:	permanent up to 100°C
class of inflammability:	UL 94 V-0

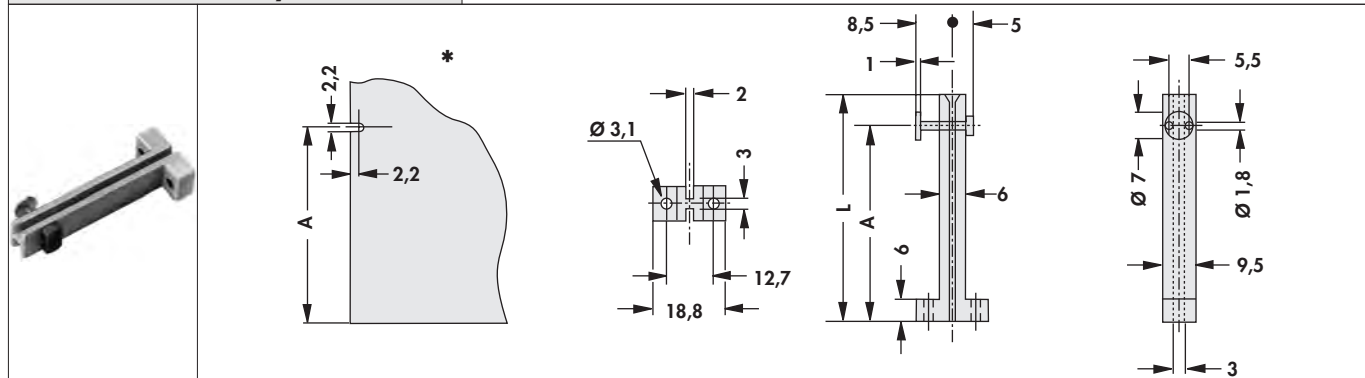

art. no.	version	dim. [mm]		art. no.	version	dim. [mm]	
		L	A			L	A
MSVL 50	with bolting device	50	42	MSVL 70	with bolting device	70	62
MSVL 60		60	52	MSVL 85		85	76

material:	polyamide, GF reinforced
temperature range:	-40°C... +205°C
class of inflammability:	UL 94 V-0

- the guide bars have got mounting holes for vertical and horizontal assembly of printed circuits
- they can also be stacked together horizontally or vertically using pins and treatments

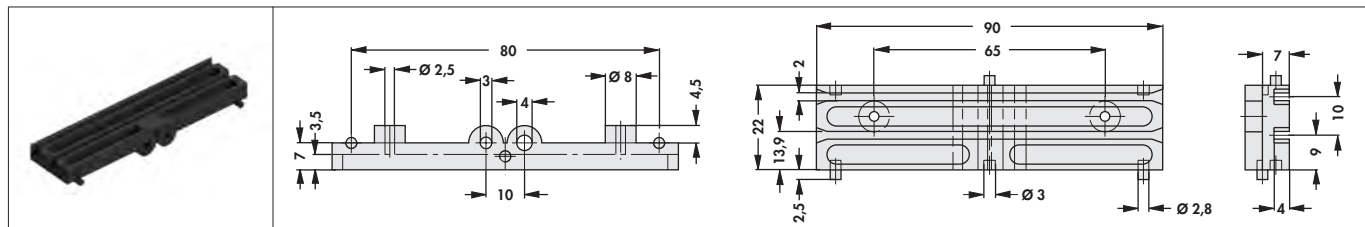

art. no.	
MSHV 90	
material:	polyamide, GF reinforced
class of inflammability:	UL 94 V-0

Guide rails

Snap-in

– narrow version

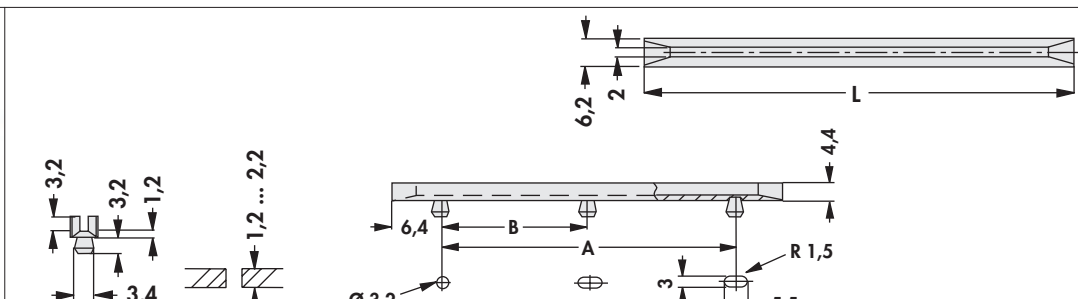
						
	art. no.	dim. [mm]		art. no.	dim. [mm]	
	L	A	L	A	B	
FS S 06 2	63.5	50.8	FS S 15 2	152.4	139.7	—
FS S 07 2	76.2	63.5	FS S 16 2	165.1	152.4	—
FS S 08 2	88.9	76.2	FS S 19 3	190.5	177.8	88.9
FS S 10 2	101.6	88.9	FS S 20 3	203.2	190.5	95.2
FS S 11 2	114.3	101.6	FS S 21 2	215.9	203.2	—
FS S 12 2	127.0	114.3	FS S 21 3			101.6
FS S 13 2	139.7	127.0				
material:		nylon, natural coloured				
temperature range:		-40°C... +120°C				
class of inflammability:		UL 94 V-2				

– wide version

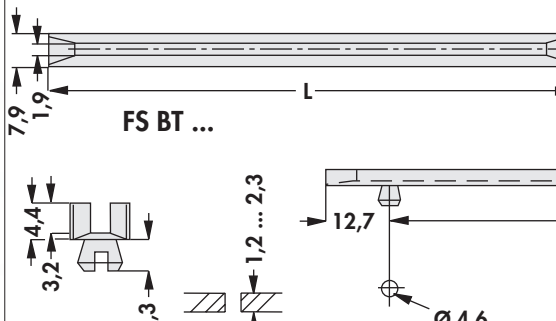
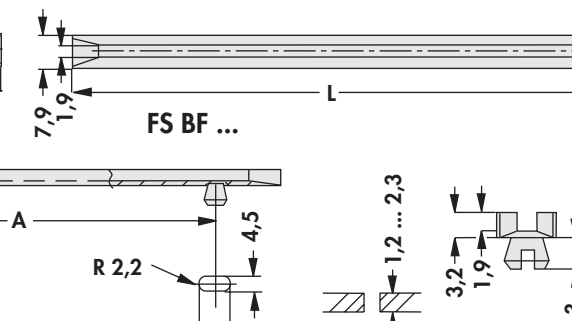
							
	art. no.	version	dim. [mm]		art. no.	version	dim. [mm]
		L	A			L	A
FS BT 06	deep groove	63.5	38.1	FS BF 06	shallow groove	63.5	38.1
FS BT 08		88.9	63.5	FS BF 07		76.2	50.8
FS BT 10		101.6	76.2	FS BF 10		101.6	76.2
FS BT 11		114.3	88.9	FS BF 11		114.3	88.9
FS BT 13		139.7	114.3	FS BF 13		139.7	114.3
FS BT 15		152.4	127.0	FS BF 15		152.4	127.0
FS BT 16		165.1	139.7	FS BF 19		190.5	165.1
FS BT 19		190.5	165.1	FS BF 20		203.2	177.8
FS BT 20		203.2	177.8				
material:		nylon, natural coloured					
temperature range:		-40°C... +120°C					
class of inflammability:		UL 94 V-2					

Ejectors

- low profile
- suitable for ejectors **art. no. AHG V 14** und **AHG V 17**

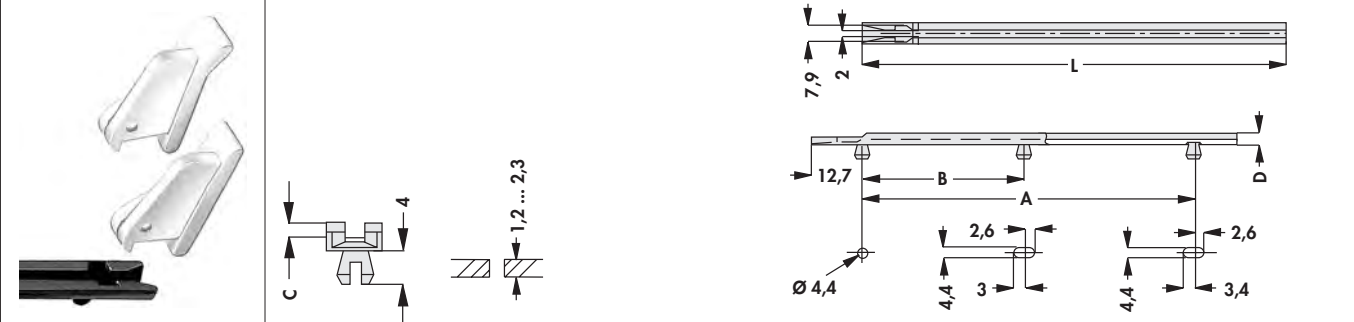

art. no.	dim. [mm]				
	L	A	B	C	D
FS LP 05	50.8	25.8	—	2.0	3.2
FS LP 07	76.2	38.5			
FS LP 08	88.9	76.6			
FS LP 10	101.6				
FS LP 11	114.3	127.4			
FS LP 13	139.7				
FS LP 15	152.4				
FS LP 16	165.1	153.2			
FS LP 17	177.8				
FS LP 22	228.6	191.3	134.0	2.4	4.0
FS LP 30	304.8	267.9			

- deep guideway
- bevelled entrance zone

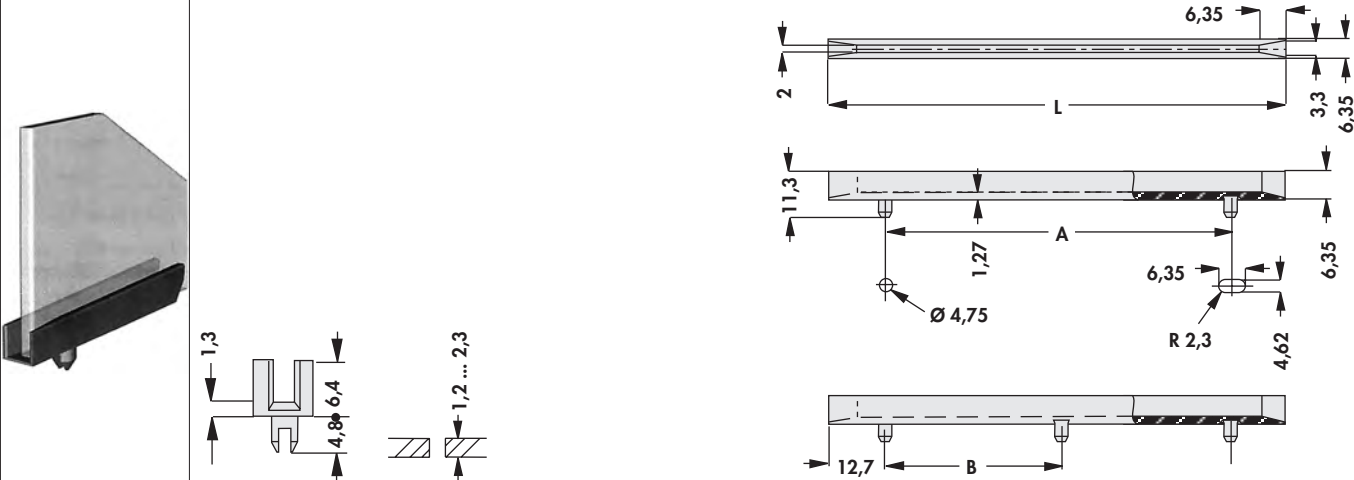

art. no.	dim. [mm]		
	L	A	B
FS U 06	63.5	38.1	—
FS U 11	114.3	88.9	
FS U 20	203.2	177.8	

material: polyamide, GF reinforced
temperature range: -40°C... +120°C
class of inflammability: UL 94 V-0



field of applications:

- insulated assembly of stacked PCB
- insulated assembly of stacked heatsinks with varying capacities
- insulated assembly of chassis plates in cases
- insulated supports in the wiring
- mechanically very stable as threads are made of brass
- other lengths on request
- dimensions = nominal size: deviation ± 0.5 mm
- ... please indicate length "C"

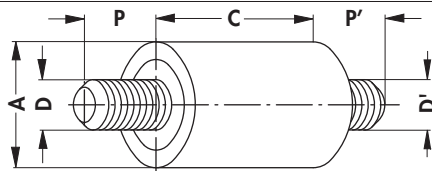

art. no.	dim. [mm]			
	A	C	D/D'	P/P'
ISAB 25 A ...	8.0	10/ 15/ 20/ 25	M2.5/M2.5	6.0
ISAB 3 A ...		10/ 20	M3/M3	
ISAB 4 A ...		15/ 20	M4/M4	
ISAB 6 A ...	12.7	25	M6/M6	12.7
creeping current resistance:	CTI 600			
thread inserts:	brass			
temperature range:	-30°C... +85°C (short term +200°C)			
surface:	raw			
plastic body:	polyamide 66			
colour:	natural (opaque)			
dielectric strength:	27 kV/mm			

Insulating spacers with internal and external thread

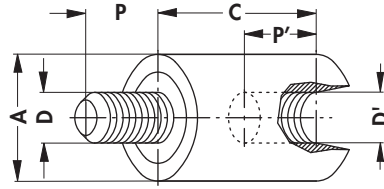

art. no.	dim. [mm]			
	A	C	D/D'	P/P'
ISAB 25 B ...	8.0	10/ 13/ 15/ 18/ 20/ 25/ 30	M2.5/M2.5	6.0
ISAB 3 B ...		10/ 13/ 15/ 18/ 20/ 25/ 30/ 35/ 40	M3/M3	
ISAB 4 B ...		15/ 20/ 25/ 30/ 40	M4/M4	
ISAB 5 B ...	9.5	20/ 30/ 40	M5/M5	10.0
ISAB 6 B ...	12.7	25/ 30/ 35/ 40/ 50	M6/M6	12.7

– dimensions = nominal size: deviation ± 0.5 mm; at **ISAB 3 C ...** L=10 \Rightarrow P/P'=3.5

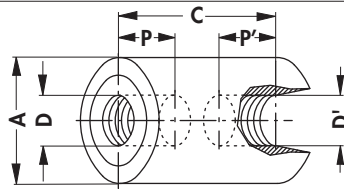

art. no.	dim. [mm]			
	A	C	D/D'	P/P'
ISAB 25 C ...	8.0	10/ 13/ 15/ 18/ 20/ 25/ 30	M2.5/M2.5	6.0
ISAB 3 C ...		10/ 13/ 15/ 18/ 20	M3/M3	
ISAB 4 C ...		15/ 35	M4/M4	
ISAB 5 C ...	9.5	20	M5/M5	10.0
ISAB 6 C ...	12.7	25	M6/M6	12.0
ISAB 6 C ...		30		12.7

creeping current resistance:	CTI 600
thread inserts:	brass
temperature range:	-30°C... +85°C (short term +200°C)
surface:	raw
plastic body:	polyamide 66
colour:	natural (opaque)
dielectric strength:	27 kV/mm

Miniature spacers with threads

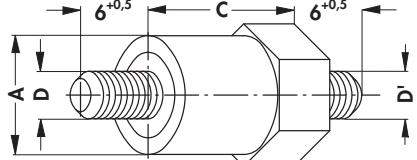
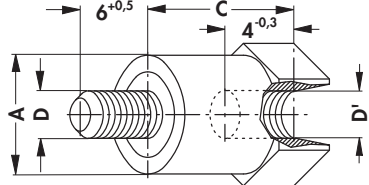
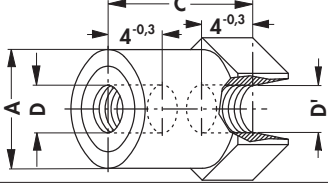

- allows compact, insulated constructions
- reduced volume in case of stack assembly
- insulated mounting of heatsinks, PCB, housingparts etc.
- very good mechanical stability due to brass inserts
- dimensions = nominal size: deviation ± 0.5 mm
- ... please indicate length "C"

			
art. no.	dim. [mm]		
	A	C	D/D'
ISAM 2 A ...	6	4/ 5/ 7/ 9/ 11/ 12	M2.5/M2.5
ISAM 3 A ...	7	4/ 5/ 7/ 8/ 9/ 10	M3/M3
			
art. no.	dim. [mm]		
	A	C	D/D'
ISAM 2 B ...	6	8/ 9/ 10/ 11	M2.5/M2.5
ISAM 3 B ...	7	7/ 8/ 9/ 10/ 11/ 12	M3/M3
			
art. no.	dim. [mm]		
	A	C	D/D'
ISAM 2 C ...	6	9	M2.5/M2.5
ISAM 3 C ...	7	9/ 10/ 12	M3/M3
creeping current resistance:	CTI 600		
thread inserts:	brass		
temperature range:	-30°C... +85°C (short term +200°C)		
surface:	raw		
plastic body:	polyamide 6		
colour:	natural (opaque)		
dielectric strength:	28 kV/mm		

**field of applications:**

- insulated assembly of stacked PCBs
- insulated assembly of stacked heatsinks with varying capacities
- insulated assembly of chassis plates in cases
- insulated supports in the wiring
- mechanically very stable, as threads are made of brass
- other lengths on request
- dimensions = nominal size: deviation ± 0.5 mm
- ... **please indicate length "C"**

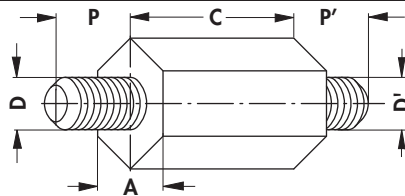

art. no.	dim. [mm]			
	A	C	D/D'	P/P'
ISAS 25 A ...	6.35	15/ 20/ 25/ 30/ 35/ 40	M2.5/M2.5	6.0
ISAS 30 A ...		15/ 20/ 25/ 30/ 35/ 40/ 45/ 50	M3/M3	
ISAS 40 A ...	8.00			M4/M4
ISAS 50 A ...	9.50	20/ 25/ 30/ 35/ 40/ 45/ 50	M5/M5	10.0
ISAS 60 A ...	12.70	25/ 30/ 35/ 40/ 45/ 50/ 60	M6/M6	12.7
creeping current resistance:	CTI 600			
thread inserts:	brass			
temperature range:	-30°C... +85°C (short term +200°C)			
surface:	raw			
plastic body:	polyamide 66			
colour:	natural (opaque)			
dielectric strength:	27 kV/mm			

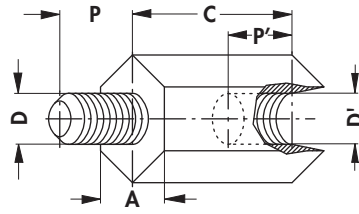

art. no.	dim. [mm]			
	A	C	D/D'	P/P'
ISAS 25 B ...	6.35	15/ 20/ 25/ 30/ 35/ 40	M2.5/M2.5	6.0
ISAS 30 B ...		15/ 20/ 25/ 30/ 35/ 40/ 45/ 50	M3/M3	
ISAS 40 B ...	8.00		M4/M4	
ISAS 50 B ...	9.50	20/ 25/ 30/ 35/ 40/ 45/ 50	M5/M5	10.0
ISAS 60 B 25	12.70	25	M6/M6	11.5
ISAS 60 B ...		30/ 35/ 40/ 45/ 50/ 60		12.7

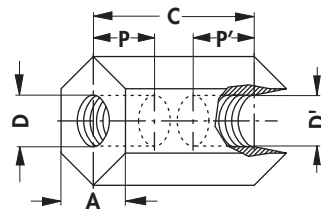

art. no.	dim. [mm]			
	A	C	D/D'	P/P'
ISAS 25 C ...	6.35	15/ 20/ 25/ 30/ 35/ 40	M2.5/M2.5	6.0
ISAS 30 C ...		15/ 20/ 25/ 30/ 35/ 40/ 45/ 50	M3/M3	
ISAS 40 C ...	8.00		M4/M4	
ISAS 50 C ...	9.50	20/ 25/ 30/ 35/ 40/ 45/ 50	M5/M5	10.0
ISAS 60 C 25	12.70	25	M6/M6	11.5
ISAS 60 C ...		30/ 35/ 40/ 45/ 50/ 60		12.7

creeping current resistance:	CTI 600
thread inserts:	brass
temperature range:	-30°C... +85°C (short term +200°C)
surface:	raw
plastic body:	polyamide 66
colour:	natural (opaque)
dielectric strength:	27 kV/mm

Spacers with internal and external thread

- other lengths and threads on request
- ... please indicate length "C"

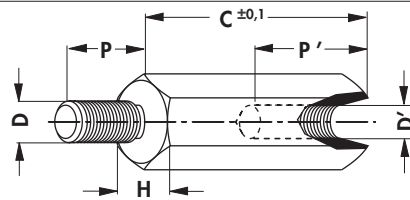

art. no.	dim. [mm]				
	H	C	D/D'	P	P'
GBM 2550 ...	5	5	M2.5	6	2.5
GBM 2550 ...		10			5.0
GBM 2550 ...		15/ 20			8.0
GBM 2550 ...		25/ 30/ 35	M3	8	10.0
GBM 3050 ...		5			2.5
GBM 3050 ...		10/ 12			5.0
GBM 3050 ...		14/ 15/ 18/ 20	M4	10	10.0
GBM 3050 ...		25/ 30/ 35/ 40/ 45/ 50			
GBM 4070 ...		5			2.5
GBM 4070 ...	10	M5	8	5.0	
GBM 4070 ...	15			8.0	
GBM 4070 ...	20			10.0	
GBM 4070 ...	25/ 30/ 35/ 40/ 45/ 50				
GBM 4070 ...					
GBM 5080 ...	8	10	M5	10	5.0
GBM 5080 ...		15/ 20			6.0
GBM 5080 ...		25/ 30/ 35/ 40/ 45/ 50			10.0
material:	brass				
surface:	6 µm nickel-plated				

- other lengths and threads on request
- ... please indicate length "C"

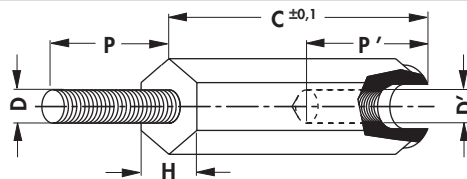

art. no.	dim. [mm]				
	H	C	D/D'	P	P'
GBP 3060 ...	6	10	M3	8	8
GBP 3060 ...		12/ 15/ 18/ 20/ 25/ 30			10
GBP 4080 ...	8	10	M4	10	8
GBP 4080 ...		12/ 15/ 18/ 20/ 25/ 30/ 35/ 40/ 45			10
material:	polyamide, GF reinforced				
temperature range:	-30°C... +110°C				
colour:	black				

Spacers with internal and external thread

- with self-cutting external thread
- external thread with undercut according to DIN 76-B
- different lengths, materials and types of thread upon request
- ... please indicate length "C"

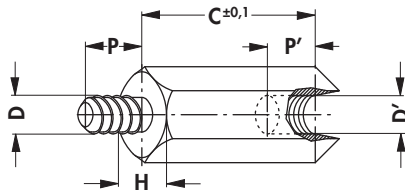

art. no.	dim. [mm]				
	H	C	D/D'	P	P'
GBMS 2550 ...	5.0	8	ST2,2/M2,5	5	5
GBMS 2550 ...		10			6
GBMS 2550 ...		12			7
GBMS 2550 ...		15/ 20			10
GBMS 3055 29 ...	5.5	8	ST2,9/M3	6	5
GBMS 3055 29 ...		10			6
GBMS 3055 29 ...		12			7
GBMS 3055 29 ...		15/ 20			10
GBMS 3055 33 ...	6.0	8	ST3,3/M3	7	5
GBMS 3055 33 ...		10			6
GBMS 3055 33 ...		12			7
GBMS 3055 33 ...		15/ 20			10
GBMS 3060 ...	7.0	8	ST3,5/M3	8	5
GBMS 3060 ...		10			6
GBMS 3060 ...		12			7
GBMS 3060 ...		15/ 20			10
GBMS 4070 ...	8.0	8	ST4,2/M4	8	5
GBMS 4070 ...		10			6
GBMS 4070 ...		12			7
GBMS 4070 ...		15/ 20			10
GBMS 5080 ...	10.0	8	ST4,8/M5	10	5
GBMS 5080 ...		10			6
GBMS 5080 ...		12			7
GBMS 5080 ...		15/ 20			10
GBMS 6010 ...	10.0	10	ST6,3/M6	10	6
GBMS 6010 ...		12			7
GBMS 6010 ...		15/ 20			10
material:	brass				
surface:	8 μm nickel-plated				

A

Distance sleeves with internal thread

- other lengths and threads on request
- ... please indicate length "C"

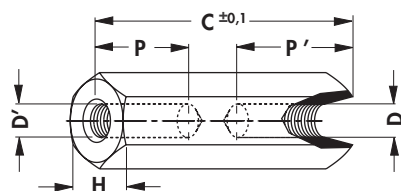

art. no.	dim. [mm]				
	H	C	D/D'	P	P'
ABM 2550 ...	5	5/ 8/ 10/ 12/ 15	M2.5	=C	—
ABM 2550 ...		18		8	8
ABM 2550 ...		20/ 25/ 30/ 35/ 40/ 45/ 50		10	10
ABM 3050 ...	5	5/ 8/ 9/ 10/ 12/ 13/ 15	M3	=C	—
ABM 3050 ...		16/ 18/ 19		8	8
ABM 3050 ...		20/ 25/ 29/ 30/ 35/ 40/ 45/ 50		10	10
ABM 4070 ...	7	5/ 8/ 10/ 12/ 15	M4	=C	—
ABM 4070 ...		18		9	9
ABM 4070 ...		20/ 25/ 30/ 35/ 40/ 45/ 50		10	10
ABM 5080 ...	8	5/ 12	M5	=C	—
ABM 5080 ...		20/ 30/ 40/ 50		10	10
material:		brass			
surface:		6 µm nickel-plated			

- other lengths and threads on request
- ... please indicate length "C"

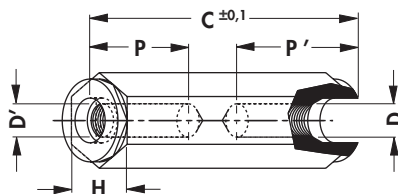

art. no.	dim. [mm]				
	H	C	D/D'	P	P'
ABP 2550 ...	5	10	M2.5	=C	—
ABP 2550 ...		15/ 20/ 25/ 30		6	6
ABP 3060 ...	6	10/ 12/ 15	M3	=C	—
ABP 3060 ...		20		8	8
ABP 3060 ...		25/ 30		10	10
ABP 4080 ...	8	10/ 15/ 20	M4	=C	—
ABP 4080 ...		30/ 40		10	10
material:		polyamide, GF reinforced			
temperature range:		-30°C... +110°C			
colour:		black			

L

M

N

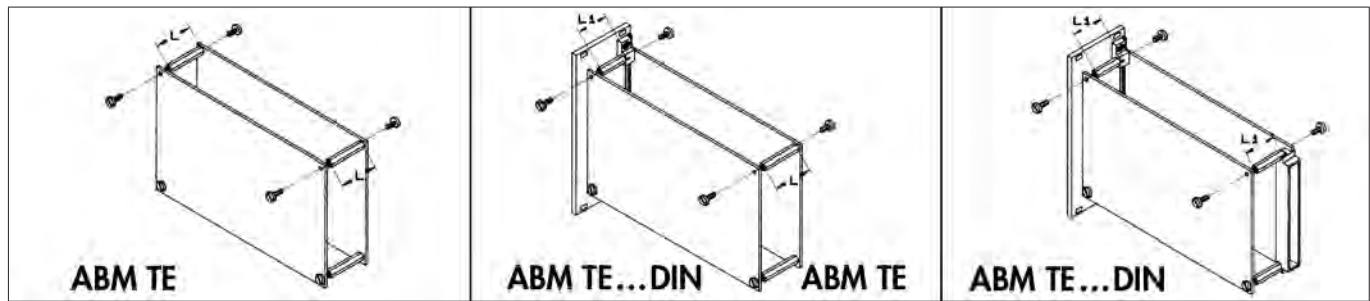

- these internally threaded distance sleeves mount PCBs to the correct pitch for insertion into subracks
- **ABM TE**: spacer between two PC boards
- **ABM TE ... DIN**: spacer between two PC boards, one of them equipped with DIN-connector resp. A front panel/PCB Interconnection device VS 1
- spacers with internal and external thread to HP grid on request

art. no.	suitable for TE	dim. [mm]			
		C		P/P'	
ABM TE 04	4	18.72		8	
ABM TE 06	6	28.88			
ABM TE 08	8	39.04			
art. no.	suitable for TE	dim. [mm]			
		C		P	
ABM TE 04 DIN	4	12.72		=C	
ABM TE 06 DIN	6	22.88		8	
ABM TE 08 DIN	8	33.04			
material:	brass				
surface:	8 μm nickel-plated				

- ... please indicate length "C"

art. no.	A	D	dim. [mm]		
			C		
AHM 3260 ...	6	3.2	1/ 2/ 3/ 4/ 5/ 6/ 7/ 8/ 9/ 10/ 12/ 15/ 18/ 25/ 30		
AHM 4380 ...	8	4.3	2/ 3/ 4/ 5/ 6/ 7/ 8/ 9/ 10/ 12/ 15/ 18/ 20		
material:	brass				
surface:	8 μm nickel-plated				

Spacers

– special lengths on request

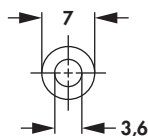

art. no.	dim. [mm] C	art. no.	dim. [mm] C	art. no.	dim. [mm] C
DR 071 V0	1	DR 079 V0	9	DR 725 V0	25
DR 072 V0	2	DR 710 V0	10	DR 730 V0	30
DR 073 V0	3	DR 711 V0	11	DR 735 V0	35
DR 074 V0	4	DR 712 V0	12	DR 740 V0	40
DR 075 V0	5	DR 713 V0	13	DR 745 V0	45
DR 076 V0	6	DR 714 V0	14	DR 750 V0	50
DR 077 V0	7	DR 715 V0	15	DR 760 V0	60
DR 078 V0	8	DR 720 V0	20		

art. no.	dim. [mm] C	art. no.	dim. [mm] C	art. no.	dim. [mm] C
DR 081 V0	1	DR 089 V0	9	DR 825 V0	25
DR 082 V0	2	DR 810 V0	10	DR 830 V0	30
DR 083 V0	3	DR 811 V0	11	DR 835 V0	35
DR 084 V0	4	DR 812 V0	12	DR 840 V0	40
DR 085 V0	5	DR 813 V0	13	DR 845 V0	45
DR 086 V0	6	DR 814 V0	14	DR 850 V0	50
DR 087 V0	7	DR 815 V0	15	DR 860 V0	60
DR 088 V0	8	DR 820 V0	20		

art. no.	dim. [mm] C	art. no.	dim. [mm] C	art. no.	dim. [mm] C
DR 105 V0	5	DR 125 V0	25	DR 145 V0	45
DR 110 V0	10	DR 130 V0	30	DR 150 V0	50
DR 115 V0	15	DR 135 V0	35		
DR 120 V0	20	DR 140 V0	40		





material:	polyamide
heat distortion:	180°C
temperature range:	+180°C
colour:	black
class of inflammability:	UL 94 V-0





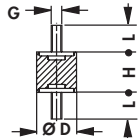

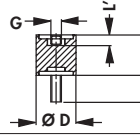

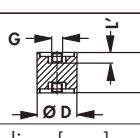
Construational elements to vibration damping and insulation

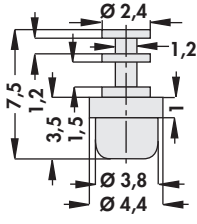
- universal applicable round metal, antivibration buffers for solving vibration problems
- other lengths and hardness range on request

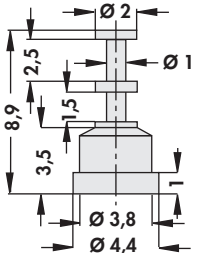
Field of applications:

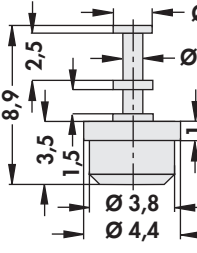
- reduction of dynamic component stress
- vibration insulation for disc drives and motors
- impact reducing on sensitive instruments
- reduction of the noise level
- prevention of vibration resonance phenomena (amplified effect)
- compensation of mechanical imbalances

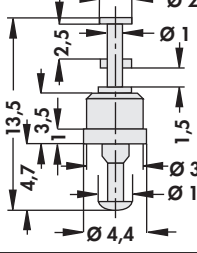
					
art. no.	dim. [mm]				
	H	type of thread	Ø D	L	
SMP 410 A 10	10	M4	10	10	
SMP 415 A 15	15		M5	15	12
SMP 515 A 15					
					
art. no.	dim. [mm]				
	H	type of thread	Ø D	L'	L
SMP 410 B 10	10	M4	10	4	10
SMP 415 B 15	15		M5		
SMP 515 B 15					
					
art. no.	dim. [mm]				
	H	type of thread	Ø D	L'	
SMP 410 C 15	15	M4	10	4	
SMP 410 C 20	20				
SMP 415 C 15	15				
SMP 415 C 20	20	M5	15	5	
SMP 515 C 20					
material:	rubber-metal connection				
rubber:	natural rubber (NR according to ISO)				
hardness:	~ 50 Shore A				
elongation and tebsile strength:	very good				
colour:	black				
metall parts:	steel tin-plated				
temperature range:	-40°C... +80°C (short term +90°C)				

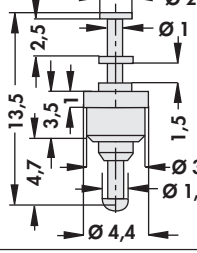
art. no. LSD 07520		
art. no. LSD 08910		
art. no. LSD 08920		
art. no. LSD 13510		
art. no. LSD 13520		
material:		insulating body: PTFE (teflon)
contact pin:		brass, 2 µm Ni, 4 µm Ag
temperature range:		-200°C ... +260°C

Solder pins

$\frac{\pm}{\text{mm}}$ = thickness

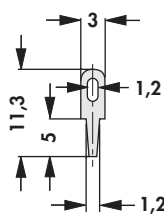
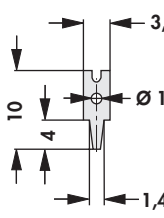
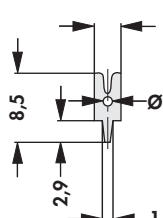
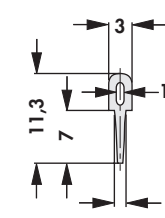
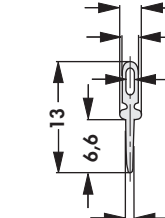
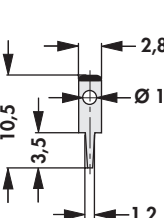
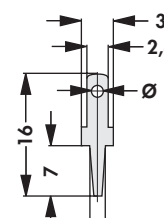
				
art. no. LS 101 $\frac{\pm}{\text{mm}}$ 0,6 mm	art. no. LS 102 $\frac{\pm}{\text{mm}}$ 0,6 mm	art. no. LS 103 $\frac{\pm}{\text{mm}}$ 0,6 mm	art. no. LS 104 $\frac{\pm}{\text{mm}}$ 0,6 mm	art. no. LS 105 $\frac{\pm}{\text{mm}}$ 0,5 mm
				
art. no. LS 106 $\frac{\pm}{\text{mm}}$ 0,8 mm	art. no. LS 107 $\frac{\pm}{\text{mm}}$ 0,5 mm			
LS				
material	brass, 6 μ m Sn			

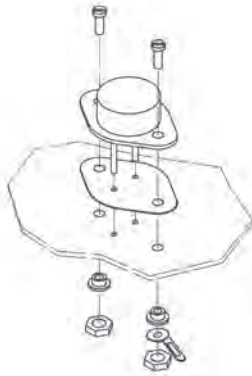
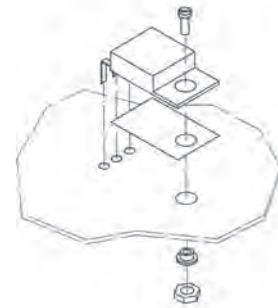
MST 3
MSTS 3

MST 220
MSTS 220

art. no.	for transistor	version	contents of delivery
MST 3	TO 3	with mica wafer GS 3	1 mica wafer, 2 insulating bushes, 1 tin-plated solder lug, 2 cheese head screws, nickel-plated, 2 screw nuts M3 nickel-plated
MSTS 3		with silicone wafer WS 3	1 silicone wafer, 2 insulating bushes, 1 tin-plated solder lug, 2 cheese head screws, nickel-plated, 2 screw nuts M3 nickel-plated
MST 220	TO 220	with mica wafer GS 220	1 mica wafer, 1 tin-plated solder lug, 1 cheese head screw, nickel-plated, 1 screw nut M3 nickel-plated
MSTS 220		with silicone wafer WS 220	1 silicone wafer, 1 insulator sleeve, 1 tin-plated solder lug, 1 cheese head screw, nickel-plated, 1 screw nut M3 nickel-plated

Snap rivet for quick fastening of TO 220

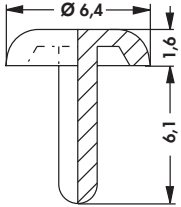
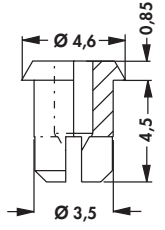
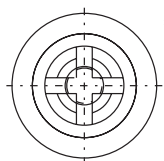



- detachable plastic snap rivet for quick fastening of transistors onto heatsinks and cooling plates (e.g. FK 212-CB, FK 216-CB, FK 222-220, FK 232, FK 233, FK 235-L 1)
- suitable for material thickness: 1 – 1.5 mm
- suitable for hole diameter: 3.5 – 4 mm
- * = bottom view, pin not inserted

			
art. no.	for transistor		
EPN 1	TO 220		
material:	polysulphone, GF reinforced		
temperature range:	-70°C... +180°C (260°C/5 s)		
class of inflammability:	UL 94 V-0		

Insulating clamping parts for power transistors

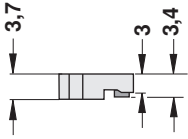
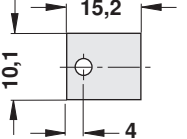
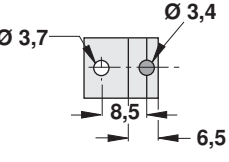
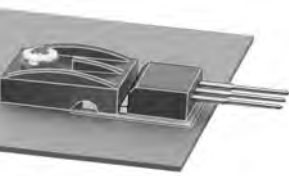
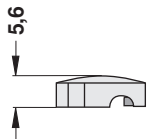
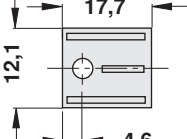
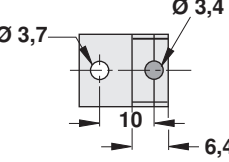
Plastic insulating clamping parts for mounting transistors in cases TO 220, TO 218 and TO 247 for enhanced dielectric strengths

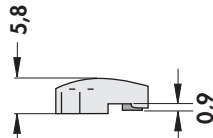
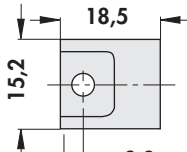
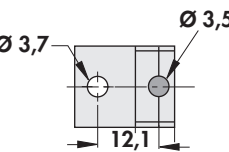
- electrically insulating assembly of the transistor by means of a plastic clamping part
- pin reaching into the hole of the transistor plate
- fastening of clamping part onto the mounting plate by screws, no electroinsulating connection to the transistor
- dielectric strength only determined by the insulating washer between transistor and mounting surface
- no insulating bush necessary, thus no dielectric breakdown

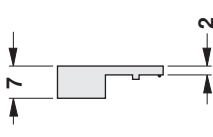
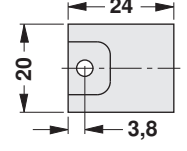
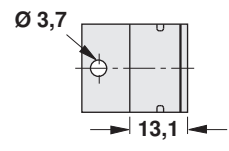
<p>art. no.</p> <p>ISP 220</p>				
<p>art. no.</p> <p>ISP 220 V</p>				
<p>art. no.</p> <p>ISP 218</p>				
<p>art. no.</p> <p>ISP 247</p>				
<p>material:</p>		<p>polyamide 6, GF reinforced</p>		
<p>heat distortion:</p>		<p>215°C(0.45 MPa); 205°C(1.8 MPa)</p>		
<p>dielectric constant:</p>		<p>4 [1 MHz]</p>		
<p>dielectric loss factor:</p>		<p>400 [1 MHz]</p>		
<p>specific volume resistance:</p>		<p>10¹⁵ Ω·cm</p>		
<p>colour:</p>		<p>black</p>		
<p>class of inflammability:</p>		<p>UL 94 V-0</p>		
<p>dielectric strength:</p>		<p>28 kV/mm</p>		

Mounting pads

- * = transfer washer: the US-pads convert the TO 5 pin circle to a pitch of 2.54 mm

art. no. MS 184 7 TO 18	art. no. MS 184 35 TO 18	art. no. MS 53 7 TO 5	art. no. US 58 4 TO 5	
material:		polyamide 6, GF reinforced		
temperature range:		-40°C... +205°C		
class of inflammability:		UL 94 V-0 (at thickness ≥3mm), UL 94 V-1		
art. no. MS 923 25 TO 92	art. no. MS 183 25 TO 18	art. no. MS 184 25 TO 18	art. no. MS 183 7 TO 18	art. no. MS 183 35 TO 18
art. no. MS 3518 25 TO 5/TO 18	art. no. MS 3518 35 TO 5/TO 18	art. no. MS 58 5 TO 5-8 p.	art. no. MS 53 25 TO 5	art. no. MS 54 25 TO 5
art. no. MS 34 518 TO 5/TO 18	art. no. MS 58 7 TO 5-8 p.	art. no. MS 53 3 TO 5	art. no. MS 56 15 TO 5-6 p.	art. no. MS 58 15 TO 5-8 p.
art. no. MS 510 15 TO 5-10 p.	art. no. MS 84 4 TO 8	art. no. MS 4016 max. 16 contacts	art. no. US 512 4 TO 5	
material:		polyamide 6, GF reinforced		
temperature range:		permanent up to 100°C		
class of inflammability:		UL 94 V-0		

Mounting pads

Mounting pads for power transistors

- for TO 220, TO 219, TO 202 and similar
- for vertical and horizontal mounting
- also suitable as mounting bracket for angled connections

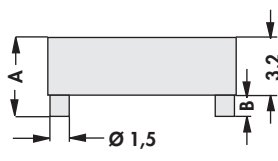
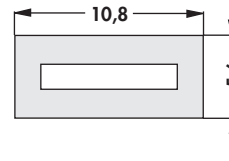
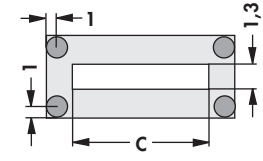
				
art. no.	colour	dim. [mm]		
		A	B	C
MLW 32	white	3.2	—	7.1
MLW 44		4.4	1.3	
MLW 51		5.1	1.9	
material:	polyamide 6 (nylon)			
temperature range:	-40°C... +120°C			
class of inflammability:	UL 94 V-2			

Mounting pads for rectangular LEDs

- for LED 2x4 mm oder 2x5 mm
- symmetric version for easy assembly
- self-adhesive

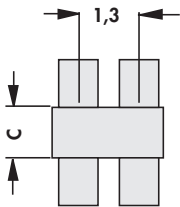
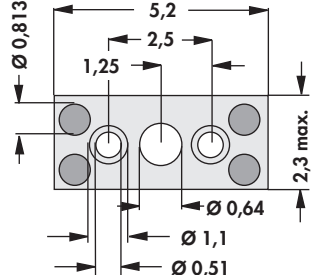
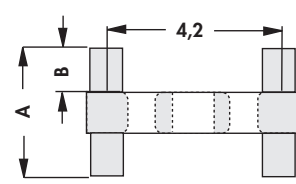
				
art. no.	colour	dim. [mm]		
		A	B	C
MRL 20	white	2	0.5	1
material:	polyamide 6 (nylon)			
temperature range:	-40°C... +120°C			
class of inflammability:	UL 94 V-2			

A

Mounting pads for discrete components

– suitable for various components e.g. resistors, capacitors etc.

B

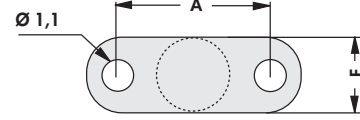
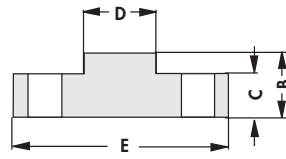

C

art. no.	dim. [mm]						art. no.	dim. [mm]					
	A	B	C	D	E	F		A	B	C	D	E	F
MD A 04	2.5	1.1	0.55	1.3	4.6	2.3	MD A 09	7.6	1.1	0.66	3.6	9.9	2.3
MD A 06	3.8			2.3	6.9	3.2	MD A 12	10.2		0.76	4.8	12.4	
MD A 07	5.1			7.4	2.3								

D

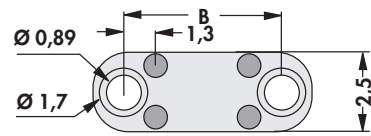
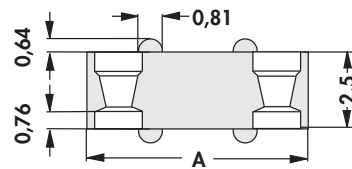

E

art. no.	dim. [mm]		art. no.	dim. [mm]	
	A	B		A	B
MD B 07	7.6	5.1	MD B 10	10.2	7.6

F

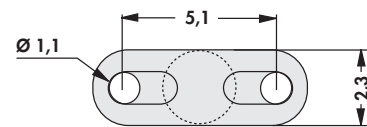
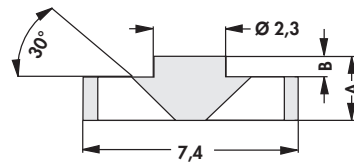

G

art. no.	dim. [mm]		art. no.	dim. [mm]	
	A	B		A	B
MD C 13	1.3		MD C 22	2.2	0.89

material:	polyamide 6 (nylon)
temperature range:	-30°C... +110°C
class of inflammability:	UL 94 V-2

H







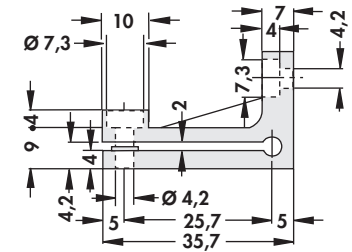
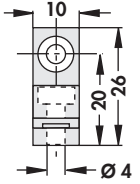

I

K

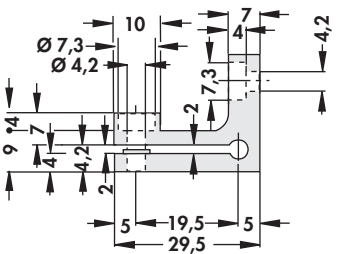
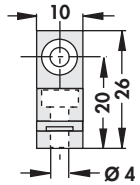
L

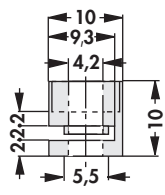
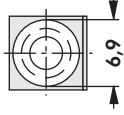
M

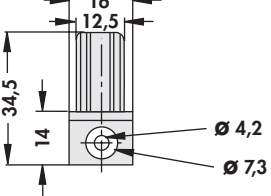
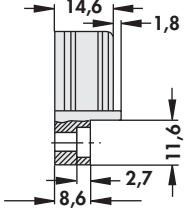

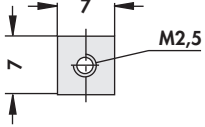
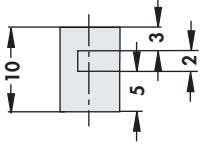
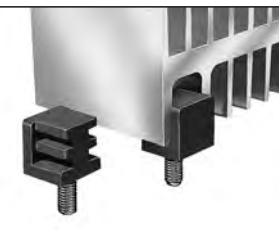
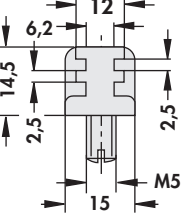
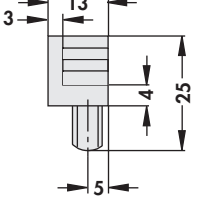
N

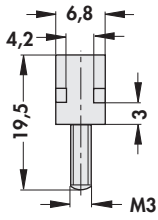
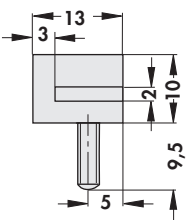
<p>art. no.</p>			
<p>IS 1</p>	<p>for SK 01, 02, 03, 14, 21, 30, 34, 36, 39, 46, 69; heatsink length: 50 mm</p>		
<p>art. no.</p>			
<p>IS 2</p>	<p>for SK 01, 02, 03, 14, 21, 30, 34, 36, 39, 46, 69; heatsink length: 37.5 75 100 mm</p>		
<p>art. no.</p>			
<p>IS 3</p>	<p>for SK 01, 02, 03, 14, 21, 30, 34, 36, 39, 46, 69</p>		
<p>art. no.</p>			
<p>IS 4</p>	<p>for SK 06</p>		
<p>art. no.</p>			
<p>IS 5</p>	<p>for SK 20</p>		
<p>art. no.</p>			
<p>IS 6</p>	<p>for SK 67</p>		
<p>material:</p>		<p>polyamide 6, GF reinforced</p>	
<p>class of inflammability:</p>		<p>UL 94 V-0</p>	

art. no. IS 8			
material: polyamide 6, GF reinforced		class of inflammability: UL 94 V-0	

Insulating caps

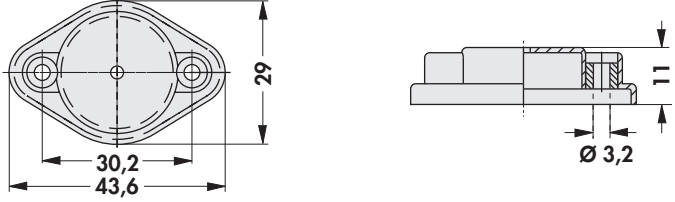
– different transistor flange levels will be by the sleeves

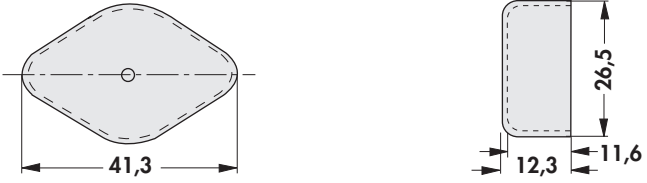
<p>art. no.</p> <p>IK 341 3</p>		
<p>material:</p>		<p>polyamide, GF reinforced</p>
<p>pressed-in sleeves:</p>		<p>brass, nickel-plated</p>
<p>class of inflammability:</p>		<p>UL 94 V-0</p>
<p>art. no.</p> <p>IK 3</p>		
<p>material:</p>		<p>polyamide, GF reinforced</p>
<p>class of inflammability:</p>		<p>UL 94 V-0</p>

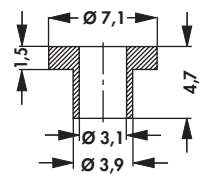
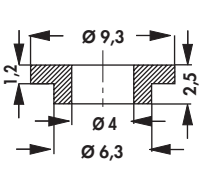
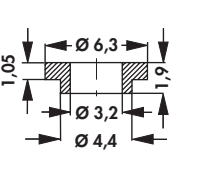
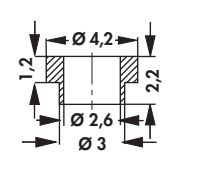
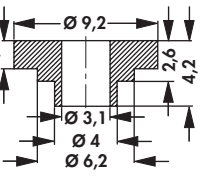
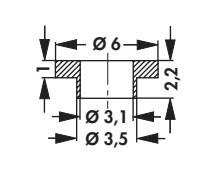
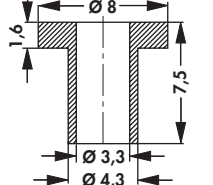
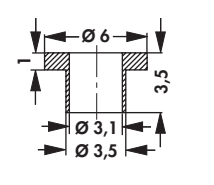
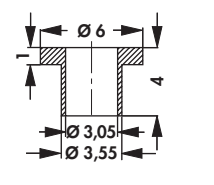
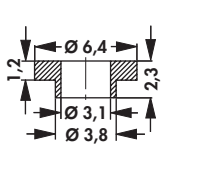
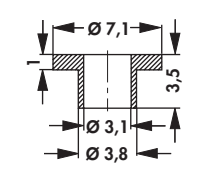
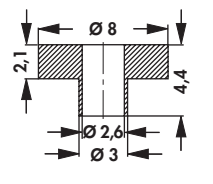
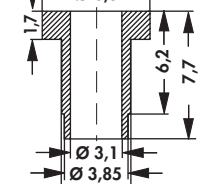
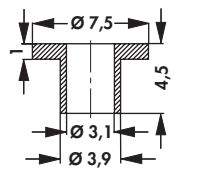
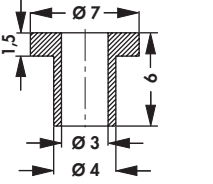
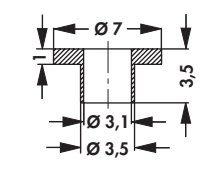
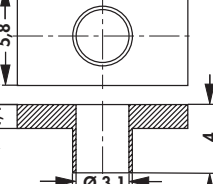
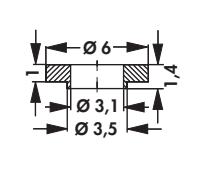
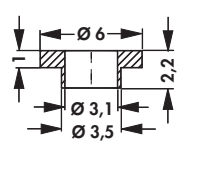
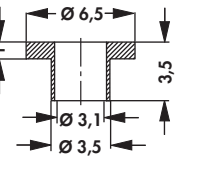
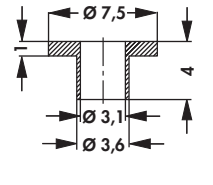
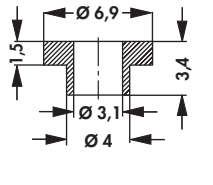
				
art. no. IB 1 / IBT 1	art. no. IB 2 / IBT 2	art. no. IB 3 / IBT 3	art. no. IB 4 / IBT 4	art. no. IB 5
				
art. no. IB 6 / IBT 6	art. no. IB 7 / IBT 7	art. no. IB 8 / IBT 8	art. no. IB 9 / IBT 9	art. no. IB 10 / IBT 10
				
art. no. IB 11 / IBT 11	art. no. IB 12 / IBT 12	art. no. IB 13	art. no. IB 14 / IBT 14	art. no. IB 15 / IBT 15
				
art. no. IB 16	art. no. IB 17	art. no. IB 18 / IBT 18	art. no. IB 19	art. no. IB 20
				
art. no. IB 21	art. no. IB 22			
		IB 1 - IB 7 / 18	IBT 1 - IBT 15 / 18	IB 8 - IB 17 / 19 - 22
material		polyamide 4.6, GF reinforced	PTFE (teflon)	thermoplastic resin
form stability		-40°C ... +250°C (1.8 MPa)	-260°C ... +250°C	-40°C ... +200°C
class of inflammability			UL 94 V-0	
dielectric strength		30 kV/mm	40 kV/mm	38 kV/mm

High quality surface treatment for electronic components



Printing

Performance: Printing on sheets, bodies, foils with higher wear resistance; multicolour anodised printing; back printing on transparent materials
 Surfaces: anodised, painted, chromated, powder-coated
 Materials: metals, plastics, ceramics, etc.
 Pad printing: max. print format: Ø 100 mm
 Screen printing: max. print format: 400 x 550 mm
 max. print height: 300 mm
 Sub-anodised printing: max. print format: 329 x 520 mm
 max. print height: 60 mm

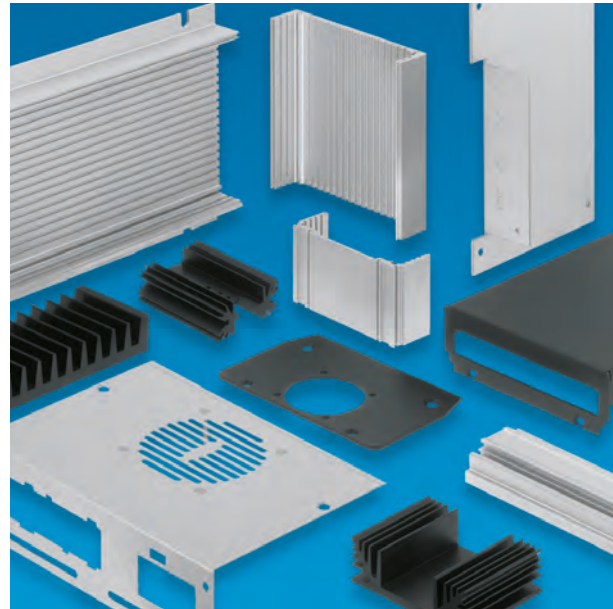

Anodising

performance: fabrication of corrosion resistant, decorative oxide films
 process: anodic oxidation in fully automated equipment
 materials: aluminium and aluminium alloys
 max. component size: 1500 x 2000 x 450 mm
 colour: natural aluminium or black



Tin-plating

properties: solderable layers with improved tarnishing and corrosion resistance
 process: drum technology
 materials: non-ferrous metals
 coating system: copper/nickel/tin



Gold-plating

properties: high resistance to wear, good corrosion resistance, temperature stability and solderability
 process: drum technology
 materials: non-ferrous metals
 coating system: copper/nickel/gold

High quality surface treatment for electronic components



Transparent passivating (chrome VI-free Surtec® 650 and chrome-free surfaces)

characteristics: environmental compatibility due to chrome free passivation of the aluminium surfaces
process: fabrication of conversion coatings by immersion process
materials: aluminium und aluminium alloys
max. component size: 1500 x 2000 x 450 mm
colour: natural aluminium

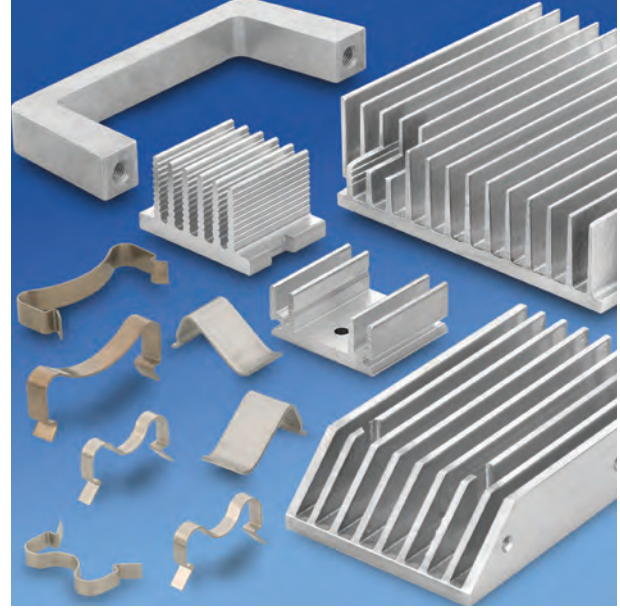

Vibratory grinding (trowalization)

characteristics: deburring, removing of sharp edges, rough and fine grinding
process: treatment using vibration technique and grinding tools (trowalization)
materials: aluminium
max. component size: 230 x 200 mm



Anodisation facility

- economization of water by using spray-rinsing, automatized ion exchange installation, cascade water guided system and recirculation of splash water
- reduction of electrical energy by means of current density regulation
- reduction of chemicals by recirculation of the dragged-off chemicals using a compensation of the evaporation losses
- recycling of the sulphuric acid out of the anodizing bathes

Certificate

Standard **ISO 9001:2015**

Certificate Registr. No. **01 100 052055**

Certificate Holder:  **Fischer Oberflächenveredelung GmbH**
Nottebohmstr. 26
58511 Lüdenscheid
Germany

Scope: Surface treatment: gold-plating, tin-plating, nickel-plating, anodising, passivating and trowalising

Proof has been furnished by means of an audit that the requirements of ISO 9001:2015 are met.

Validity: The certificate is valid from 2023-12-15 until 2026-12-14.
First certification 2005

2023-11-07

TÜV Rheinland Cert GmbH
Am Grauen Stein · 51105 Köln

Terms and conditions of business

1. General provisions

1.1. The present General Terms and Conditions (GTC) apply to all of our business relationships with our customers ("Purchaser"). The GTC only apply if the Purchaser is an entrepreneur (§ 14 of the German Civil Code), a legal entity of public law or a special fund under public law.

The GTC particularly apply for contracts about the sale and/or the delivery of transportable objects ("Goods"), regardless of whether we manufacture the Goods ourselves or buy them in from suppliers (§§ 433, 651 of the German Civil Code). Unless otherwise agreed, the GTC apply, in the version valid at the time of the Purchaser's order or in the version last transmitted to them, as a framework agreement for similar future contracts, without us having to refer to them each time.

1.2. Our GTC apply exclusively. Deviating, contradicting or additional General Terms and Conditions of the Purchaser are only part of the contract if we have expressly authorised their validity. This approval requirement applies in any case, also if we make deliveries to the Purchaser without reserve, in full knowledge of their Terms and Conditions. Individual, isolated agreements with the Purchaser (including ancillary agreements, additions and changes) always take priority over these GTC. The content of this type of agreement, subject to counter-evidence, is to be determined according to a written contract or our written confirmation.

1.3. Legally relevant declarations and announcements of the Purchaser with regards to the contract (for example deadline agreements, defect notifications, withdrawal or reduction) are to be submitted in writing, i.e. in written or text form (for example letter, e-mail, fax). Legal form provisions and other certificates, especially in case of doubts about the legitimation of the declaring party, remain unaffected.

1.4. References to the validity of legal provisions are only for clarification purposes. The legal provisions therefore apply even if there is no reference, unless they have been modified directly in these GTC or expressly excluded.

2. Quotations and orders

Our quotations shall be subject to change without notice and are non-binding. This applies also to information contained in price lists, leaflets etc. Delivery dates stated in our quotations or given to the purchaser by any other means are approximate, and we shall endeavour to keep to them. Delays in delivery shall give us no right to claims, unless we have explicitly confirmed such delivery dates and an adequate period of grace granted to us has expired. Orders shall only be binding on us when they have been explicitly confirmed in writing, regardless of the form in which they have been placed with us. Statements made in catalogues are simple descriptions of goods and under no circumstances do they constitute warranted qualities. Furthermore, the characteristics of our samples cannot be regarded as warranted characteristics.

3. Prices

Prices shall be valid only when confirmed by us in writing. They are exclusive of VAT at the current rate and incidentals such as postage and packing, freight, insurance etc., as of storage. If delivery is made more than 3 months after the date of order, we shall be entitled to invoice the price valid at the date of despatch, even though different prices were initially confirmed. The price valid at the date of despatch shall also apply if the order was confirmed without prices being stated. When an order on call is placed, partial deliveries shall be invoiced at the price valid at the date of despatch. Any request by the purchaser for subsequent modifications shall entitle us to amend prices.

4. Conditions of payment

The invoiced sum is to be paid net within 30 days of date of invoice and delivery. If the purchaser is in default with any payment, we are entitled to claim interest for such default at the normal rate of interest charged for current accounts. If we are able to prove that we have incurred greater losses as a result of the delay, we shall be entitled to claim compensation for such damages. We are however entitled at any time, in the context of an ongoing business relationship, to execute a delivery in full or in part only against an advance deposit. We shall declare a corresponding reserve at the latest at the confirmation of the contract.

5. Set-off, right to retention

Only claims which have been recognised by us or have become legally binding may be offset against our invoices. Any right to a retention to be exercised by the purchaser in connection with our claims is explicitly excluded. In case of defects in the delivery, the rights of the Purchaser remain unaffected, particularly with regards to point 10.3. of these GTC.

6. Delivery

The delivery is performed from the storage, wherever the place of fulfilment for the delivery and any subsequent fulfilment may be. Upon request by the Purchaser, the Goods will be sent to a different place of their choice (shipped purchase). Delivery of our goods is explicitly made on behalf of and at the risk of the purchaser. The risk shall pass over to the purchaser when the ordered goods leave our premises. The same applies if goods are collected in our premises from the point in time at which we notify the purchaser that they are ready for collection. Unless we have received instructions to the contrary from the purchaser, we shall decide at our discretion on the most economical delivery method without assuming any liability for the chosen means of delivery.

7. Specially manufactured goods

Components made according to a sample or a drawing or by special request must be taken over and paid for, unless they have a defect we are answerable for and which makes the components completely unfit for the purchaser's purposes. If their fitness for the purchaser's purposes is only reduced, the purchaser may request a reduction of payment but the contract shall not be cancelled.

8. Quantities

We are entitled to supply quantities which are above or below the ordered quantities by up to 10%. Such deviations are usual in this trade and the deliveries are deemed as being in compliance with the contract. If delivery quantities fall below the ordered quantities there shall be no right to subsequent delivery of the missing quantity.

9. Reservation of proprietary rights

9.1. All goods supplied shall remain our property until all current and future claims resulting from the Purchase contract and the business relationship with the purchaser (secured claims) have been paid in full. The purchaser is entitled to dispose of the purchased goods in the ordinary course of business transactions. Reservation of proprietary rights also applies to products resulting from processing, mixing up or combining our goods, in which case we are considered as manufacturers. In the case where our goods are processed, mixed up or combined with goods of third parties, and the proprietary rights of such third parties remain in force, we are entitled to co-ownership according to the proportion of the amount invoiced for such processed goods. In such cases such rights to co-ownership shall be safeguarded by the purchaser.

9.2. The purchaser shall transfer to us, as a security, his claims against third parties resulting from the re-sale of our goods in full or in the proportion of our co-ownership (see subparagraph 9.1). He is entitled to collect the amount of such claims on our behalf until revoked or until cessation of his payments made to us. The purchaser is not entitled to assign these claims to third parties.

9.3. The purchaser is not entitled to mortgage or transfer the goods which are subject to reservation by way of security.

9.4. The purchaser shall advise us immediately at any seizure of our goods or of any infringement of our rights by third parties.

9.5. In case of a default in payment or a deterioration in the financial situation, we are entitled to request immediate handing over of the goods which are subject to reservation. Any time limited claims shall immediately become due.

9.6. If the value of the securities exceeds our claims by more than 20%, securities to a corresponding amount will be released by us on request at our discretion.

9.7. The extended retention of title (9.1.) does not apply to prepayment orders that have been paid in full.

10. Warranty

10.1. We expressly point out that all information and data is given to the best of our knowledge and belief. The user is solely responsible for the proper use of our products and he should check their suitability for the intended application. Fischer Elektronik do not assume any warranty, whether expressed or implied, for the suitability, function or merchantability of their products in specific or general applications, and they cannot be held liable for accidental or consequential damage due to non-observance of the above.

10.2. Claims for defects can only be considered if the purchaser has complied with their obligation to check goods and submit a complaint as per Sections 377, 381 of the German Commercial Code [HGB]. If goods have a defect attributable to us, we are obliged to effect a cure, excluding the purchaser's right to withdraw from the contract or to reduce the purchase price

(reduction), unless we are entitled to refuse to effect a cure by virtue of legal regulations. The purchaser shall grant us an adequate period of grace for effecting a cure. A cure may at our discretion be an elimination of the defect (rectification) or the supply of new products. We are entitled to determine the cure owed according to the payment of the purchase price due by the Purchaser. The Purchaser, however, is entitled to retain a part of the purchase price that is proportionate to the defect. The expenses incurred for the verification and cure, particularly transport, road, work and materials costs (not: expansion and installation costs) are borne by us, if there is indeed a defect. Otherwise, we can require that the Purchaser bear the costs arising from the unjustified defect rectification request (particularly examination and transport costs), unless the Purchaser could not have been aware that the defect rectification was unnecessary.

10.3. If rectification of the defect has failed, the purchaser shall be entitled to request a reduction in the purchase price (abatement) or to withdraw from the contract. Rectification shall be deemed to have failed after the second vain attempt, unless further attempts are reasonable in view of the object of the contract and can be reasonably imposed on the purchaser.

10.4. The purchaser's right to put forward further claims for damages shall remain unaffected by this.

10.5. The purchaser's warranty claims shall be subject to a time limit of 12 months from the delivery of the goods to the purchaser, unless we have fraudulently concealed the defect. In this case, the legal regulations shall apply.

10.6. The purchaser's claims for damages shall be subject to a time limit of 12 months from the delivery of the goods. This does not apply if we, our legal representatives or other vicarious agents are responsible for death, personal injury or physical harm, or if we or our legal representatives have been grossly negligent, or if our vicarious agents have acted with intent.

10.7. Contractual penalties which have been agreed between our customers and their customers cannot be imposed upon us unless we have been notified of them and have agreed to them in writing prior to accepting an order.

10.8. If it becomes apparent (by the opening of an application for an insolvency procedure for example) after the conclusion of the contract that our claims to the purchase price are endangered due to lacking payment capacities of the Purchaser, we will then be entitled to refuse the delivery and – after a possible period of notice – to withdraw from the contract in accordance with the legal provisions (§ 321 of the German Civil Code). For contracts about the manufacturing of specific items (making to specification), we can declare the withdrawal immediately; the legal regulations about the dispensability of giving a period of notice remain unaffected.

11. Withdrawal

When delivery in accordance with the contract is not possible for reasons beyond our control, we are entitled to withdraw from the contract. Such withdrawal shall not entitle the purchaser to assert any right against us.

12. Export clause







We are not obliged to reimburse damages arising from delays in delivery or it being completely impossible to deliver as a result of statutory or official export restrictions, unless we act with intent or gross negligence suffered by the Customer or other persons. The Customer's duty to pay the agreed remuneration shall not be affected by disruptions in our performance as a result of export restrictions. We shall be entitled to withdraw from the contract if, after the contract is signed, our performance is disrupted as a result of export restrictions.

13. Place of performance and jurisdiction, applicable law

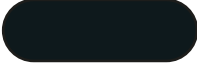
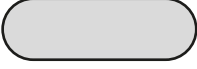

13.1. The place of performance and the place of venue for deliveries and payments and for any litigation arising between us and the purchaser shall be the headquarters of our company.

13.2. The relationship between the contractual parties shall be regulated solely in accordance with the law in force in the Federal Republic of Germany. The regulations of international uniform law, particularly the UN CISG, shall not apply.



art. no.	HEATSINKS SURFACES & CASES SURFACES		
----------	-------------------------------------	--	--

AL		natural aluminium/degreased/cutting edges not deburred (not degreased/cutting edges not deburred when sold by the metre)	
BZ		raw pickled aluminium	
LP		outside black lacquered RAL 9005 / chrome-free transparent passivated	
ME		clear anodised	
MI		solderable surface	
SA		black anodised	
TP		chrome-free transparent passivated	

art. no.	CONNECTOR CONTACT SURFACE FINISH		
----------	----------------------------------	--	--

G		gold-plated	
S		selective gold-plated	
Z		tin-plated	

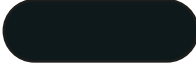
art. no.	RAL	COLOURS	ARTICLES
----------	-----	---------	----------

NB	5022	 night blue	system cases "RackCase"
S	9005	 deep black	TG / shell cases / system cases "RackCase"
TB	5018	 turquoise blue	system cases "RackCase"
UL	5002	 ultramarine blue	Plusline

The surface coatings and colours listed here in the catalogue only represent the standard designs. Other coating types and colours can be realised on request according to customer-specific requirements.



Cases
19" technology
Accessories

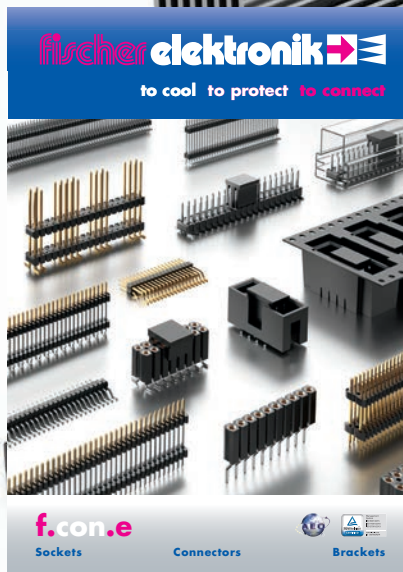

Sockets
Connectors
Brackets



Slip-Case for
collecting the Fischer
catalogues

Fischer Elektronik GmbH & Co. KG

Nottebohmstraße 28 • 58511 Lüdenscheid
GERMANY

Phone +49 2351 435-0

Fax +49 2351 45754

info@fischerelektronik.de

www.fischerelektronik.de/en

